

END USER INSTRUCTIONS

*Receivers: R15-01, R15-02,
R15-07, R15-08,
R15-13, R15-14*

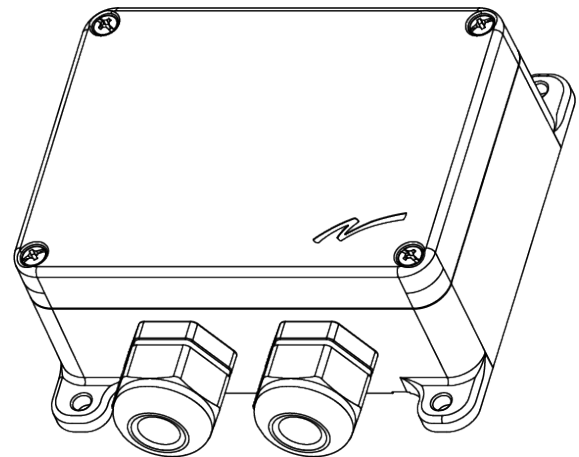

IMPORTANT! This document is intended for R15 receivers with software version SW0014-14v24 or higher.

For receivers with software version SW0014-14v23 or lower, please refer to the installation instructions IM-PN-RX103-A04-EN.

©Tele-Radio i Lysekil AB

August Barks gata 30A

SE-421 32 Västra Frölunda

Sweden

Phone: +46 (0)31 748 54 60

CONTENTS

CHAPTER 1: INTRODUCTION	4
1.1 About this document	6
1.2 About R15 receivers	7
CHAPTER 2: SAFETY	8
2.1 Warnings & restrictions	8
CHAPTER 3: TECHNICAL DATA	11
3.1 Receiver specifications	11
3.2 Current consumption	12
CHAPTER 4: PRODUCT GENERAL DESCRIPTION	13
4.1 Receiver description	13
4.2 Mechanical installation	14
CHAPTER 5: OPERATION	15
5.1 General information	15
5.2 Radio mode	16
5.3 Login/logout function	16
5.4 Relay functions	16
CHAPTER 6: WARRANTY, SERVICE, REPAIRS, AND MAINTENANCE	17
CHAPTER 7: REGULATORY INFORMATION	18
7.1 Europe	18
7.2 United Kingdom	19
ANNEX A: FREQUENT TERMS	20
ANNEX B: INDEX	22

CHAPTER 1: INTRODUCTION

Thank you for using a Tele Radio product



READ ALL INSTRUCTIONS AND WARNINGS CAREFULLY BEFORE OPERATING THE PRODUCTS.

These End user instructions have been published by Tele Radio and are not subject to any guarantees. The End user instructions may be withdrawn or revised by Tele Radio at any time and without further notice. Corrections and updates will be added to the latest version of the manual. Always download the End user instructions from our website, www.tele-radio.com, for the latest available version. Keep the safety instructions for future reference.

IMPORTANT! These instructions are intended for end users. The instructions can be printed and handed to end user.

Tele Radio remote controls are often built into wider applications. This documentation is not intended to replace the determination of suitability or reliability of the product for specific user applications and should not be used for this purpose. It is the responsibility of any such users or integrators to perform the appropriate and complete risk analysis, evaluation and testing of the products with respect to the relevant specific application or use. Tele Radio shall not be responsible or liable for misuse of the information contained herein.

Always refer to the applicable local regulations for installation and safety requirements relating to cranes, hoists, material handling applications, lifting equipment, industrial machinery, and/or mobile hydraulic applications using Tele Radio products, e.g.:

- applicable local and industrial standards and requirements,
- applicable occupational health and safety regulations,
- applicable safety rules and procedures for the factory where the equipment is being used,
- user and safety manuals or instructions of the manufacturer of the equipment where Tele Radio remote control systems are installed.

Tele Radio End user instructions do not include or address the specific instructions and safety warnings of the end product manufacturer.

Tele Radio products are covered by a warranty against material, construction, or manufacturing faults. See "Chapter 6: Warranty, service, repairs, and maintenance".

1.1 About this document

Before installing or operating the product, read the corresponding documentation carefully.

Tele Radio's product range is composed of transmitters, receivers, and accessories intended for use together as a system.

These End user instructions cover general safety issues, main technical specifications, and standard operating instructions. Images shown in this document are for illustrative purposes only.

Please report any error or omission in this document, as well as any improvement or amendment suggestion to td@tele-radio.com.

1.1.1 TERM AND SYMBOL DEFINITIONS

The capitalized terms and symbol used herein shall have the following meaning:

- **WARNING:** indicates a hazardous situation which, if not avoided, could result in death or serious injury.
- **CAUTION:** indicates a hazardous situation which, if not avoided, will result in minor or moderate injury.
- **IMPORTANT:** is used for information that requires special consideration.
- **NOTE:** is used to address practices not related to physical injury.



This symbol is used to call attention to safety messages that would be assigned the signal words "WARNING" or "CAUTION".

1.2 About R15 receivers

R15 receivers have simplex communication and work in either discontinuous or continuous mode.

There are six models.

	Base board	Base board	Expansion board
	48–230 V AC 4 relays*	12–24 V AC/DC 4 relays*	6-relay
R15-01	● (48–230 V AC)	–	○
R15-02	● (48–230 V AC)	–	●
R15-07	● (24–48 V AC)	–	○
R15-08	● (24–48 V AC)	–	●
R15-13	–	●	○
R15-14	–	●	●

● Standard ○ Optional¹ – Not available

*For more details, see "Chapter 3: Technical data".

¹Must be purchased separately.

CHAPTER 2: SAFETY

2.1 Warnings & restrictions



Carefully read through the following safety instructions before proceeding with the installation, configuration, operation, or maintenance of the product. Failure to follow these warnings could result in death or serious injury.

This product must not be operated without having read and understood the End user instructions, the specific technical documentation (for customized systems), and having received the appropriate training. The purchaser of this product has been instructed how to handle the system safely. The following information is intended for use as a complement to applicable local regulations and standards.

IMPORTANT! Tele Radio remote controls are often built into wider applications.

These systems should be equipped with:

- a wired emergency stop where necessary
- a brake
- an audible or visual warning signal

2.1.1 OPERATION



This radio system must not be used in areas where there is a risk of explosion.



This equipment is not suitable for use in locations where children are likely to be present.



Only qualified personnel should be permitted to access the transmitter and operate the equipment.

The user should:



- Always follow operating and maintenance instructions as well as all applicable safety procedures and requirements.
- Do not open the receiver encapsulation unless you are qualified.
- You must satisfy the age requirements in your country for operating the equipment.
- It is strictly prohibited to operate the equipment under the influence of drugs, alcohol and/or medications.
- Always test the transmitter stop button before operating it. Press the stop button then twist and pull it out. This test should be done on each shift, without a load.
- Never use a transmitter if the stop button is mechanically damaged. Contact your supervisor or representative for service immediately.
- Never leave the transmitter unattended.
- Always switch the transmitter off when not in use. Store in a safe place.
- Keep a clear view of the work area at all times.

2.1.2 MAINTENANCE



Before maintenance intervention on any remote controlled equipments:

- always remove all electrical power from the equipment.
 - always follow lockout procedures.
-
- Keep the safety information for future reference. Always download the End user instructions from our website, www.tele-radio.com, for the latest available version.
 - If error messages are shown, it is very important to find out what caused them. Contact your representative for help.
 - The functionality of the stop button should be tested at least after every 200 hours' use.
 - If the stop button is mechanically damaged, do not use the transmitter. Contact your supervisor or representative for service immediately.
 - Do not try to open the encapsulation.
 - Always contact your representative for service and maintenance work on the product.

- Keep contacts and antennas clean.
- Wipe off dust using a clean, slightly damp cloth.
- Never use cleaning solutions.
- Check the encapsulation, foils and cable for damages every day. If you use the product although the encapsulation or foil is damaged, moisture can cause serious damage to the electronics.

CHAPTER 3: TECHNICAL DATA

3.1 Receiver specifications

NOTE: When the equipment controlled by the receiver's standard relays is connected via the stop relays, make sure that the maximum current through the stop relays is still within the specifications.

	R15-01	R15-02	R15-07	R15-08	R15-13	R15-14
Supply voltage	48–230 V AC [-12%...+15%]		24–48 V AC [-8%...+25%]		12–24 V AC/DC [-40%...+35%]	
Number of stop relays	2 (potential free*)					
Stop relays maximum resistive load	10 A, 250 V AC					
Stop relays maximum inductive load	4 A, 250 V AC					
Number of relays	4	10	4	10	4	10
	(potential free*, 10A, 250V AC or 30 V DC) ¹					
Relay functionality	Momentary, latching, interlocking (programmable)					
Digital inputs	–					
Radio frequency band	2405–2480 MHz					
Frequency management	Direct Sequence Spread Spectrum (DSSS)					
Number of channels	16 (channel 11–26)					
Radio communication	Simplex					
Max. number of registered transmitters	8					
Antenna	Internal antenna					
IP code	IP66					
Operating temperature	-20...+55 °C / -4...+130 °F					
Safety levels	EN ISO 13849-1, PLd CAT3 (Stop function)					
Dimensions (LxWxH)	120 x 117 x 51 mm / 4.7 x 4.6 x 2 in					
Weight	400 g / 0.8 lbs					

* Potential free means that a supply voltage is needed to get voltage out of a relay.

¹ For resistive load only.

3.2 Current consumption

Input power	R15-01, R15-02		R15-07, R15-08		R15-13, R15-14	
	Min.*	Max.**	Min.*	Max.**	Min.*	Max.**
12 V AC	–	–	–	–	0.03 A	0.3 A
24 V AC	–	–	0.02 A	0.2 A	0.02 A	0.2 A
48 V AC	0.01 A	0.09 A	0.01 A	0.09 A	–	–
115 V AC	0.005 A	0.03 A	–	–	–	–
230 V AC	0.003 A	0.02 A	–	–	–	–
12 V DC	–	–	0.03 A	0.3 A	0.03 A	0.3 A
24 V DC	–	–	0.02 A	0.2 A	0.02 A	0.2 A

*Minimum current consumption = Receiver powered, no active relays, no radio session established.

**Maximum current consumption = Receiver powered, all relays on the receiver active, radio session established.

CHAPTER 4: PRODUCT GENERAL DESCRIPTION

The pictures shown in this chapter are for illustrative purposes only.

4.1 Receiver description

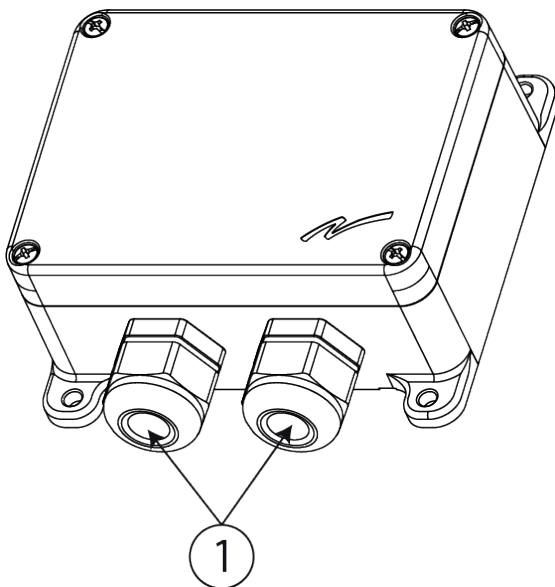

1. Cable glands (M20x1.5)

4.2 Mechanical installation

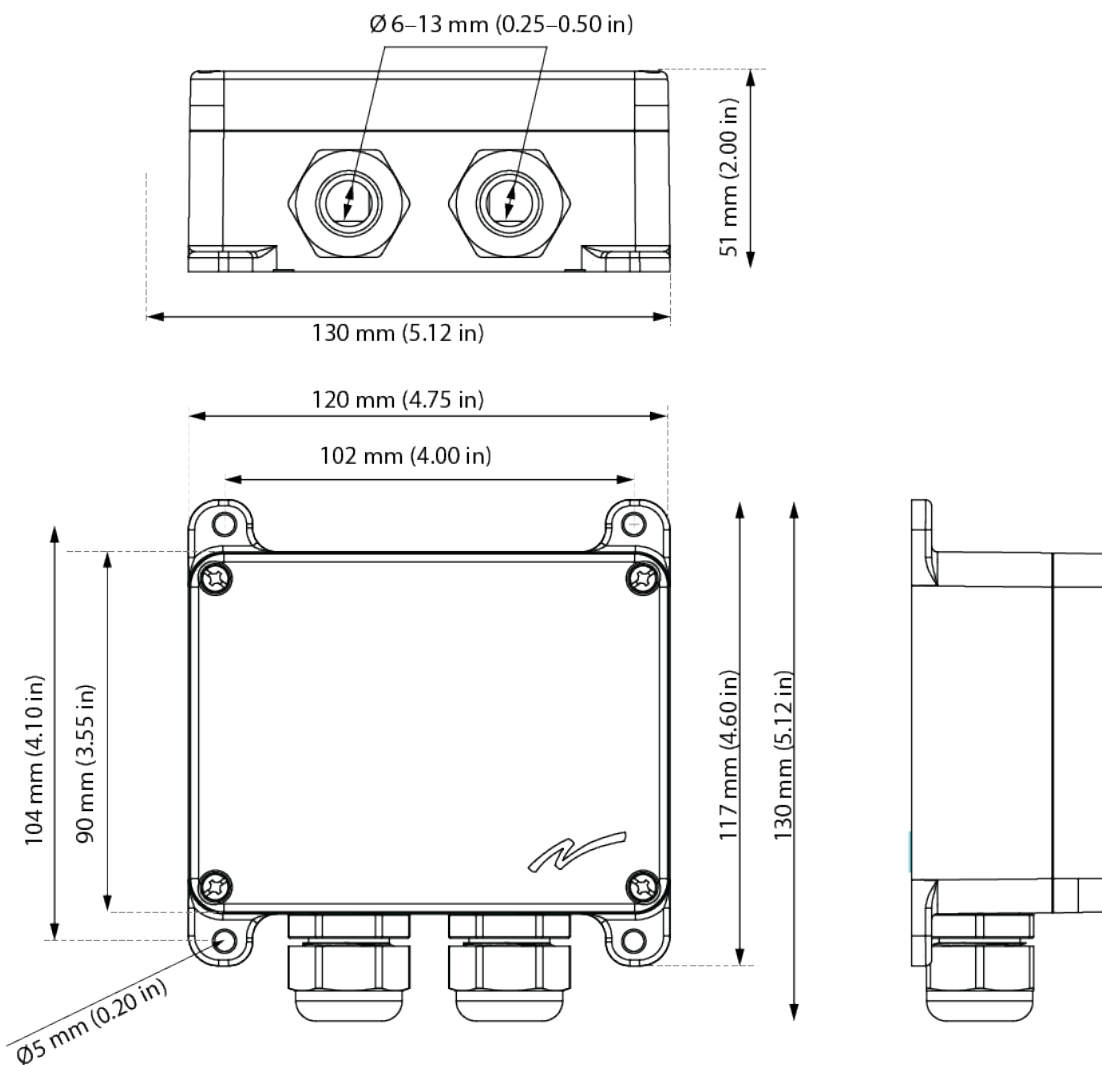

NOTE: For mounting on a wall or equipment, use 4 M5x30 mm screws or equivalent fastening method.

CHAPTER 5: OPERATION

5.1 General information

5.1.1 RECEIVERS WITH LOGIN/LOGOUT¹ FUNCTION ACTIVATED

To control a receiver, the transmitter must be registered and logged in to the receiver. If another transmitter is already logged in to the receiver, it must be logged out before a different transmitter can be logged in.

If no transmitter is logged in to the receiver, the first registered transmitter to be started will automatically log in to the receiver. Once a transmitter has been logged in, it will remain logged in until it is manually logged out.

More than one transmitter can be registered in the receiver, but only one transmitter can be logged in at a time.

5.1.2 RECEIVERS WITHOUT LOGIN/LOGOUT FUNCTION OR WITH LOGIN/LOGOUT FUNCTION INACTIVATED

To control a receiver, the transmitter must be registered in the receiver.

If no transmitter is controlling the receiver, the first registered transmitter to be started will automatically take control of the receiver. Switching the transmitter off will free the receiver and allow any other registered transmitter that is started to control the receiver.

More than one transmitter can be registered in the receiver, but only one transmitter can control the receiver at a time.

NOTE: If the login/logout function is inactivated the receiver is not PLd compliant.

5.1.3 MULTIPLE TRANSMITTERS REGISTERED IN A SAME RECEIVER

If more than one transmitter is registered in the same receiver, it is recommended to select the same frequency channel on all transmitters.

¹For more information about login/logout, see "5.3 Login/logout function"

5.2 Radio mode

NOTE: The radio mode is determined by the selected **Operating mode**. To establish a radio link between the transmitter and receiver, both units need to be set to the same radio mode.

This receiver is set to **continuous** radio mode by default.

Some settings can only be selected when the products are transmitting continuously. These settings are marked with the text: "Only for continuous radio mode".

5.3 Login/logout function

NOTE: Only for **continuous** radio mode.

For this receiver, the login/logout function is activated by default.

Logging out means stopping the communication between the transmitter and the receiver, and freeing the receiver for another registered transmitter to log in.

5.4 Relay functions

This receiver is set to **momentary** relay functionality by default. The relay remains active while a button is pressed on the transmitter. When the button is released the relay deactivates. Setting a relay to latching means that the relay becomes active when a button is pressed and remains active until the button is pressed again.

CHAPTER 6: WARRANTY, SERVICE, REPAIRS, AND MAINTENANCE

Tele Radio products are covered by a warranty against material, construction and manufacturing faults. During the warranty period, Tele Radio may replace the product or faulty parts. Work under warranty must be performed by Tele Radio or by an authorized service center specified by Tele Radio.

The following are **not** covered by the warranty:

- Faults resulting from normal wear and tear
- Parts of a consumable nature
- Products that have been subject to unauthorized modifications
- Faults resulting from incorrect installation and use
- Damp and water damage

Maintenance

- Repairs and maintenance must be performed by qualified personnel
- Only use spare parts from Tele Radio
- Contact your representative for service or any other assistance
- Keep the product in a clean, dry place
- Keep contacts and antennas clean
- Wipe off dust using a slightly damp, clean cloth

NOTE: Never use cleaning solutions or high-pressure washer.

CHAPTER 7: REGULATORY INFORMATION

NOTE: Models including additional naming conventions:

Model	Article names	Additional naming conventions
R15	R15-01	R00015-01, R15-1, PN-R15-1, PN-R15-01
	R15-02	R00015-02, R15-2, PN-R15-2, PN-R15-02
	R15-07	R00015-07, R15-7, PN-R15-7, PN-R15-07
	R15-08	R00015-08, R15-8, PN-R15-8, PN-R15-08
	R15-13	R00015-13, PN-R15-13
	R15-14	R00015-14, PN-R15-14

7.1 Europe

Applies to: **R15-01, R15-02, R15-07, R15-08, R15-13, R15-14**

7.1.1 CE MARKING

 Hereby, Tele-Radio i Lysekil AB, declares that the product(s) listed above is/are in compliance with the Radio Equipment Directive 2014/53/EU.

The latest version of the complete EU Declaration of Conformity is available at the following website: www.tele-radio.com.

7.1.2 WEEE DIRECTIVE



This symbol means that inoperative electrical and electronic products must not be mixed with household waste. The European Union has implemented a collection and recycling system for which producers are responsible. For proper treatment, recovery and recycling, please take this product to a designated collection point.

Tele Radio strives to minimize the use of hazardous materials, promotes reuse and recycling, and reduces emissions to air, soil and water. When a commercially viable alternative is available, Tele Radio strives to restrict or eliminate substances and materials that pose an environmental, health or safety risk.

7.2 United Kingdom

Applies to: **R15-01, R15-02, R15-07, R15-08, R15-13, R15-14**

7.2.1 UKCA MARKING



UK Importer: Tele Radio (UK) LTD

1 SEYMOUR COURT,
MANOR PARK, RUNCORN, WA7 1SY, UK
Email: sales@teleradiouk.com

The latest version of the complete UKCA Declaration of Conformity is available on request. Contact your representative for more information.

ANNEX A: FREQUENT TERMS

Configuration ID	Numerical code stored in both the transmitter and receiver unit. The receiver unit can only be controlled by a transmitter with the correct configuration ID.
Continuous radio mode	When in continuous radio mode the transmitter unit transmits continuously when it is switched on.
Custom ID	Numerical code stored in the transmitter unit, used to replace the unique ID code. One or several transmitter units can be configured with the same custom ID and the receiver will recognise them all as the same transmitter unit.
Discontinuous radio mode	When in discontinuous radio mode the transmitter unit transmits whenever it is switched on and a button is pressed. The transmission is interrupted when all buttons are released.
Function relay	Standard relay, controlled by the buttons on the transmitter unit.
Interlocking	Prevents a component from functioning when another component is functioning or operating in a particular way.
Latching relay functionality	The relay becomes active every time you press a button and remains active until the button is pressed again.
Load select mode	One or more Load select modes are stored in the transmitter unit. Activating a specific Load select mode results in a group of preselected relays on the receiver unit, which may be controlled from the transmitter unit.
Momentary relay functionality	The relay will only be active while a button is pressed on the transmitter. When the button is released, the relay will no longer be active.

On relay	Relay that is active when the receiver unit is operating and a radio link is established, regardless of whether any other relays are active.
Operating mode	One or more Operating modes are stored in the receiver unit. Each Operating mode describes which relays on the receiver unit are controlled when specific buttons on the transmitter unit are pressed.
Replace ID	Numerical code used to identify the transmitter during the Replace procedure.
Stop relay	Safety related relay controlled by the stop button on the receiver. Intended to interrupt the power supply to a safety application controlled by the receiver unit.
Work relay	Relay that is active when any other specified relay(s) on the receiver unit is/are active.
Zero position check	Security function ensuring that potentially active buttons/joysticks upon start up or lost/found radio links must be in the zero position before the system can be used to avoid unplanned movements of the controlled object.

ANNEX B: INDEX

A

About R15 receivers	7
---------------------------	---

C

CE marking	18
------------------	----

Current consumption	12
---------------------------	----

D

Dimensions	11
------------------	----

I

IP code	11
---------------	----

L

Login/Logout	16
--------------------	----

Login/Logout function	16
-----------------------------	----

M

Maintenance	17
-------------------	----

Mounting dimensions

Receiver	14
----------------	----

N

Number of channels	11
--------------------------	----

O

Operating temperature	11
-----------------------------	----

P

Power supply	11
--------------------	----

R

Radio communication	11
---------------------------	----

Radio frequency band	11
----------------------------	----

Radio mode	16
------------------	----

Relay functions	16
S	
Safety standards	11
Specifications	11
U	
UKCA marking	19
W	
Warnings & restrictions	8
Maintenance	9
Operation	8
WEEE directive	18
Weight	11

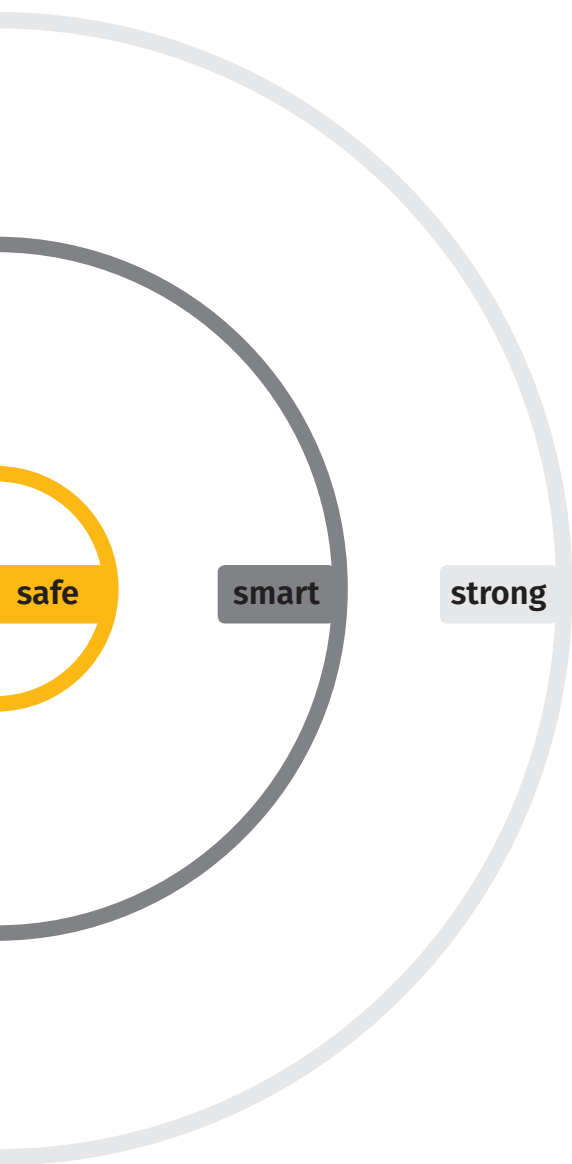

 **tele radio**[®]
wireless solutions

These End user instructions are subject to change without prior notice.

Download the latest End user instructions from www.tele-radio.com .