

INSTALLATION INSTRUCTIONS

Receivers:

R23-01, R23-03

R23-02, R23-04

safe

smart

strong

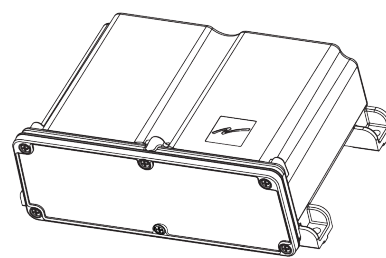
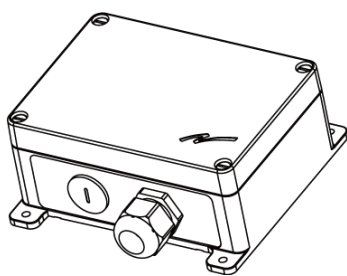

IMPORTANT! This document is intended for R23 receivers with software version SW0028-09v09 or higher.

©Tele-Radio i Lysekil AB

August Barks gata 30A

SE-421 32 Västra Frölunda

Sweden

Phone: +46 (0)31 748 54 60

CONTENTS

CHAPTER 1: INTRODUCTION	5
1.1 About this document	6
1.2 About R23 receivers	7
CHAPTER 2: SAFETY	8
2.1 Warnings & restrictions	8
CHAPTER 3: FUNCTIONAL SAFETY	12
3.1 Safety function	12
3.2 Applicable products	12
3.3 Installation	12
3.4 Configuration	12
3.5 Interface	14
CHAPTER 4: TECHNICAL DATA	15
4.1 Common specifications	15
4.2 Other specifications	16
4.3 Current consumption	17
CHAPTER 5: PRODUCT GENERAL DESCRIPTION	18
5.1 Receiver description	18
5.2 Mechanical installation	19
5.3 Antenna	22
CHAPTER 6: BOARD DESCRIPTION	25
6.1 Position of the printed circuit boards	25
6.2 Base board	27
6.3 Expansion boards	31
CHAPTER 7: STATUS AND ERROR INDICATIONS	42
7.1 Function LEDs indication in normal operation	42
7.2 CANopen run status (LED8)	43
7.3 CANopen error status (LED7)	43
7.4 J1939 run status (LED8)	45
7.5 J1939 error status (LED7)	45
7.6 Menu mode indications	46
7.7 Error indications and code messages	47
CHAPTER 8: OPERATION	51
8.1 General information	51
8.2 Radio mode	52
8.3 Relay functions	52
8.4 Login/logout function	52
CHAPTER 9: CONFIGURATION MENU	53
9.1 Menu mode	53
9.2 Register the transmitter in the receiver	54
9.3 Set momentary or latching relay functions	55

9.4 Show settings	56
9.5 Operating modes	57
9.6 Active Load select	64
9.7 Register a batteryless button (BLB) transmitter	66
9.8 Log a transmitter out	68
9.9 Erase all registered transmitters	69
9.10 Master reset of the receiver	69
CHAPTER 10: WARRANTY, SERVICE, REPAIRS, AND MAINTENANCE	70
CHAPTER 11: REGULATORY INFORMATION	71
11.1 Europe	71
11.2 United Kingdom	71
11.3 North America	72
ANNEX A: CANOPEN SPECIFICATION FOR R23 (IN ENGLISH)	75
A.1 Introduction	75
A.2 General	75
A.3 Bus termination	76
A.4 Selection of CANopen node ID	76
A.5 Selection of CANopen baud rate	76
A.6 Configuration of CANopen object dictionary	77
A.7 LED indications	77
A.8 Internal states	78
A.9 Pre-defined connection set	79
A.10 Transmit Process Data Objects (TPDO) overview	80
A.11 Receive Process Data Objects (RPDO) overview	81
A.12 Manufacturer Specific Objects	82
A.13 Emergency Object (EMCY)	88
A.14 Object Dictionary	89
ANNEX B: J1939 SPECIFICATION FOR R23 (IN ENGLISH)	93
B.1 Introduction	93
B.2 General	93
B.3 LED indications	95
B.4 Supported PGNs Tx (Request messages transmitted)	96
B.5 Supported PGNs Rx (Request messages accepted)	101
ANNEX C: GLOSSARY	103
ANNEX D: INDEX	104

CHAPTER 1: INTRODUCTION

Thank you for purchasing a Tele Radio product



READ ALL INSTRUCTIONS AND WARNINGS CAREFULLY BEFORE MOUNTING, INSTALLING, CONFIGURING AND OPERATING THE PRODUCTS.

These Installation instructions have been published by Tele Radio and are not subject to any guarantees. The Installation instructions may be withdrawn or revised by Tele Radio at any time and without further notice. Corrections and updates will be added to the latest version of the manual. Always download the Installation instructions from our website, www.tele-radio.com, for the latest available version. Keep the safety instructions for future reference.

IMPORTANT! These instructions are intended for installers and authorized service and distribution centers. The instructions containing information about the installation and configuration of the radio remote control unit on the machine are NOT intended to be passed on to the end user. Only information that is needed to operate the machine correctly by radio remote control may be passed on to the end user.

Tele Radio remote controls are often built into wider applications. This documentation is not intended to replace the determination of suitability or reliability of the product for specific user applications and should not be used for this purpose. It is the responsibility of any such users or integrators to perform the appropriate and complete risk analysis, evaluation and testing of the products with respect to the relevant specific application or use. Tele Radio shall not be responsible or liable for misuse of the information contained herein.

Always refer to the applicable local regulations for installation and safety requirements relating to cranes, hoists, material handling applications, lifting equipment, industrial machinery, and/or mobile hydraulic applications using Tele Radio products, e.g.:

- applicable local and industrial standards and requirements,
- applicable occupational health and safety regulations,
- applicable safety rules and procedures for the factory where the equipment is being used,
- user and safety manuals or instructions of the manufacturer of the equipment where Tele Radio remote control systems are installed.

Tele Radio Installation instructions do not include or address the specific instructions and safety warnings of the end product manufacturer.

Tele Radio products are covered by a warranty against material, construction, or manufacturing faults. See "Chapter 10: Warranty, service, repairs, and maintenance".

1.1 About this document

Before installing or operating the product, read the corresponding documentation carefully.

Tele Radio's product range is composed of transmitters, receivers, and accessories intended for use together as a system.

These Installation instructions cover general safety issues, main technical specifications, standard installation, configuration and operating instructions, as well as general troubleshooting. Images shown in this document are for illustrative purposes only.

Please report any error or omission in this document, as well as any improvement or amendment suggestion to td@tele-radio.com.

1.1.1 COPYRIGHT

Information in this document is subject to change without notice. No part of this publication may be reproduced, stored in a retrieval system, or transmitted in any form or by any means, electronic, photographic, mechanical (including photocopying), recording or otherwise for any purpose other than the purchaser's personal use without the written permission of Tele Radio.

1.1.2 TERM AND SYMBOL DEFINITIONS

The capitalized terms and symbol used herein shall have the following meaning:

- **WARNING:** indicates a hazardous situation which, if not avoided, could result in death or serious injury.
- **CAUTION:** indicates a hazardous situation which, if not avoided, will result in minor or moderate injury.
- **IMPORTANT:** is used for information that requires special consideration.
- **NOTE:** is used to address practices not related to physical injury.



This symbol is used to call attention to safety messages that would be assigned the signal words "WARNING" or "CAUTION".

1.2 About R23 receivers

Tele Radio's remote control systems are suitable for a wide variety of applications for e.g. stationary or mobile equipments, hydraulic machines, construction, forestry or agriculture equipments and more. Tele Radio's transmitters and receivers are highly customizable and can be configured to suit the most wide-ranging application requirements & usage habits.

R23 receivers have simplex communication and can work in either discontinuous or continuous mode. There are eight models available:

	Casing type		Main board	Expansion boards			Bus system
	1 (yellow / black)	2 (black)	10 relays	5-relay	14- relays	DI	CAN/RS485
R23-01	●		●	○	○	○	○
R23-02		●	●	○	○	○	○
R23-03	●		●	●	○	○	○
R23-04		●	●	●	–	○	○

● Standard; ○ Optional¹; – Not possible

¹Must be purchased separately.

CHAPTER 2: SAFETY

2.1 Warnings & restrictions



Carefully read through the following safety instructions before proceeding with the installation, configuration, operation, or maintenance of the product. Failure to follow these warnings could result in death or serious injury.

This product must not be operated without having read and understood the Installation instructions and having received the appropriate training. The purchaser of this product has been instructed how to handle the system safely. The following information is intended for use as a complement to applicable local regulations and standards.

IMPORTANT! Tele Radio remote controls are often built into wider applications.

These systems should be equipped with:

- a wired emergency stop where necessary
- a brake
- an audible or visual warning signal

2.1.1 INSTALLATION AND COMMISSIONING

IMPORTANT! Only licensed or qualified personnel should be permitted to install the product.



This radio system must not be used in areas where there is a risk of explosion.



Always switch off all electrical power from the equipment before installation procedure.



To utilize the safety features of the system, use the stop relays in the safety circuitry of the object/ equipment to be controlled.



When the equipment controlled by the receiver's standard relays is connected via the stop relays, make sure that the maximum current through the stop relays is still within the specifications. Contact your representative for assistance.



RISK OF UNINTENDED EQUIPMENT OPERATION

Only transmitters that are intended for use should be registered in the receiver.

Failure to follow these instructions could result in death, serious injury, or equipment damage.



RISK OF ELECTRIC SHOCK

The receiver must only be opened by qualified installers or authorized personnel.

Make sure the power supply is switched off before opening the receiver.

Failure to follow these instructions could result in death, serious injury, or equipment damage.



- **The receiver must be securely attached and located where it will not be hit by e.g. any moving parts.**
- **Do not install the product in areas affected by strong vibrations**
- **Cable glands and vent plugs must face downwards to prevent water ingress.**
- **Ensure that the power supply is connected to the correct terminals.**
- **Ensure that flexible cords and cables are not damaged through friction or stress.**
- **Do not use damaged cables.**
- **Ensure cables and connectors do not hang loose.**

- The receiver is designed to withstand normal weather conditions but should be protected from extreme conditions.
- Install the receiver in a location where the LED is easily visible and the button accessible.
- Make sure to install available accessories inside or on the receiver before permanently installing the receiver. A permanent installation of the product must include fuse protection of the equipment and cables against short circuits.

2.1.2 OPERATION



This equipment is not suitable for use in locations where children are likely to be present.



Only qualified personnel should be permitted to access the transmitter and operate the equipment.



- Make sure that the user satisfies the age requirements in your country for operating the equipment.
- Make sure that the user is not under the influence of drugs, alcohol and medications.
- Make sure that the user knows and follows operating and maintenance instructions as well as all applicable safety procedures and requirements.

The user should:



- Always test the transmitter stop button before operating it. This test should be done on each shift, without a load.
- Never use a transmitter if the stop button is mechanically damaged. Contact your supervisor or representative for service immediately.
- Never leave the transmitter unattended.
- Always switch the transmitter off when not in use. Store in a safe place.
- Keep a clear view of the work area at all times.

2.1.3 MAINTENANCE



Before maintenance intervention on any remote controlled equipments:

- always remove all electrical power from the equipment.
- always follow lockout procedures.

- Keep the safety information for future reference. Always download the Installation instructions from our website, www.tele-radio.com, for the latest available version.
- If error messages are shown, it is very important to find out what caused them. Contact your representative for help.
- The functionality of the stop button should be tested at least after every 200 hours' use.

- If the stop button is mechanically damaged, do not use the transmitter. Contact your supervisor or representative for service immediately.
- Keep contacts and antennas clean.
- Wipe off dust using a clean, slightly damp cloth.
- Never use cleaning solutions.
- Check the encapsulation, foils and cable for damages. If the encapsulation or foil is damaged, moisture can cause serious damage to the electronics.

CHAPTER 3: FUNCTIONAL SAFETY

NOTE: The information in this section applies only to the products specified below.

3.1 Safety function

The safety-related stop function in the radio system complies with **EN 13849-1:2015 PLd category 3**. The stop relays on the receiver unit are controlled by the stop button on the transmitter unit. When the stop button is pressed, the stop relays interrupt the power to the safety-related application. The complete end-user system, including the radio system, enters a safe state. The maximum response time for the safety-related stop function is 500 ms.

Safety function	Mission time	MTTFd	DC _{avg}	Category	Achieved PL
Stop function	20 years	90 years	99 %	3	d

3.2 Applicable products

The following transmitters are **designed to comply with the appointed safety requirements when used together with a R23 receiver**:

- T19-02, T29-12

NOTE: Both the receiver and the transmitter used in the specific end-user system must be compliant.

3.3 Installation

The two stop relays on the receiver unit shall be correctly installed/integrated to the end-user system requirements.

NOTE: The safety level of the stop function on the complete end-user system depends on other sub system(s) and needs to be calculated by the manufacturer of the complete system.

3.4 Configuration

The default configuration of the receiver unit complies with the appointed safety requirements. Any reconfiguration that breaches the safety requirements will be indicated by a LED on the main board of the receiver unit. Before commissioning the radio system, the installer must check the LED indication.

Function LED	Status	Indicates
PLd status LED (red)	ON	Not compliant with PLd
	OFF	Compliant with PLd

R23

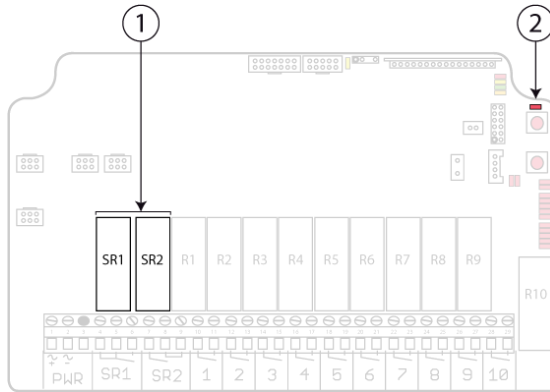

1. Stop relays SR1–2

2. PLd status LED (red)

IMPORTANT! All safety-related parameters must be configured as follows in order to comply with the appointed safety requirements:

- The system must be configured in continuous radio mode.
- The stop relays must be switched off when the radio link is down.
- The radio link timeout must be set to a maximum of 500 ms.
- The login/logout function must be activated.
- The Custom ID setting must be deactivated, i.e. the receiver must always use the unique transmitter ID code.
- The parameter 'START status in Gen1 packet for session' must be activated. See "3.4.1 'START status'/'START bit' parameters" for more details.
- The parameter 'START bit in Gen2 packet for session' must be activated. See "3.4.1 'START status'/'START bit' parameters" for more details.

3.4.1 'START STATUS'/'START BIT' PARAMETERS

When the transmitter¹ is started it will send start commands for 200 ms.

- **If both 'START status' and 'START bit' parameters are activated, the receiver is PLd compliant.**

The receiver will not activate the stop relays until it receives a start command from the transmitter. This is to make sure that the stop relays will not

¹T19-02, T29

activate immediately if the receiver is restarted after a temporary loss of power and the transmitter is still active.

If the receiver has received a start command and the transmitter goes out of range for more than six minutes, a new start packet will be required (i.e. the transmitter will have to be restarted).

- **If one or both 'START status' or 'START bit' parameters are not checked, the receiver is NOT PLd compliant.**

The stop relays are activated as soon as the receiver receives packets without pressing any button on the transmitter.

3.5 Interface

The radio system comprises one SRP/CS (as defined in EN 13849-1:2015), including the stop button (input), the stop relays (output) and the safety-related logic maintaining the stop function (logic).

The interfaces to the SRP/CS are the stop button (as controlled by the operator) and the stop relays.

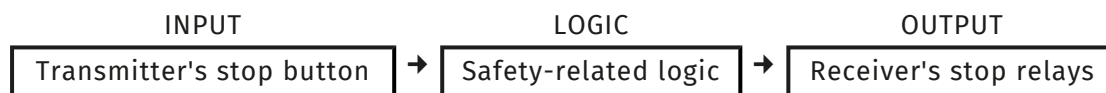

→: Interconnection

CHAPTER 4: TECHNICAL DATA

4.1 Common specifications

Power supply	12–24 V AC/DC, 48–230 V AC, 50–60 Hz, max. 1 A
Number of stop relays	2 (potential free*, 10 A, 250 V AC)
Relay functionality	Momentary, latching, interlocking (programmable)
Radio type	Low IF topology
Radio frequency band	2405 – 2480 MHz
Frequency management	Direct Sequence Spread Spectrum (DSSS)
Number of Channels	16 (channel 11 – 26)
Radio communication	Simplex
Radio frequency output power	EIRP ¹ < 10 dBm (10 mW)
Max. number of registered transmitters	16
Antenna Standard Optional	Internal antenna External antenna
IP code	IP66
Operating temperature	-20...+55 °C / -4...+130 °F
Safety levels	EN ISO 13849-1 PLd CAT3 (stop function, see "Chapter 3: Functional safety")

* Potential free means that a supply voltage is needed to get voltage out of a relay.

¹Equivalent isotropic radiated power

4.2 Other specifications

4.2.1 R23-01, R23-03 (HOUSING 1)

	R23-01	R23-03
Number of relays	10	15
	potential free ¹ , 10 A, 250 V AC	
Number of digital inputs	–	–
Number of digital outputs	2	5
Bus system	–	–
Connector	Cable gland M25 x 1.5 (PA66)	
Dimensions	176 x 160 x 75 mm / 6.9 x 6.3 x 3 in	
Weight (typical)	745 g / 1.64 lbs	832 g / 1.83 lbs

4.2.2 R23-02, R23-04 (HOUSING 2)

	R23-02	R23-04
Number of relays	10	15
	potential free, 10 A, 250 V AC	
Number of digital inputs	–	–
Number of digital outputs	2	5
Bus system	–	–
Connector	Customizable (e.g. Harting 10, 16 or 24 pin, or cable gland. Must be purchased separately).	
Dimensions	209 x 147 x 71 mm / 8.23 x 5.8 x 2.8 in	
Weight (typical)	919 g / 2.02 lbs	943 g / 2.08 lbs

¹* Potential free means that a supply voltage is needed to get voltage out of a relay.

4.3 Current consumption

Input power	R23-01, R23-02		R23-01, R23-02 with CAN and RS485 exp. boards		R23-02 with 14-relay exp. board	
	Min.*	Max.**	Min.*	Max.**	Min.*	Max.**
12 V AC	100	428	144	482	106	785
24 V AC	52	175	72	192	55	332
48 V AC	33	105	44	115	35	210
115 V AC	15	45	19	48	16	80
230 V AC	11	25	13	27	12	42
12 V DC	105	355	143	390	109	645
24 V DC	55	188	76	203	57	330

Input power	R23-03, R23-04		R23-03 with 14-relay and DI exp. boards	
	Min.*	Max.**	Min.*	Max.**
12 V AC	100	580	108	950
24 V AC	52	226	55	388
48 V AC	34	138	35	265
115 V AC	15	56	16	90
230 V AC	10	30	11	47
12 V DC	105	455	109	740
24 V DC	55	237	58	379

*Minimum current consumption = receiver powered, no active relays, no radio session established.

**Maximum current consumption = receiver powered, all relays on the receiver active, radio session established.

CHAPTER 5: PRODUCT GENERAL DESCRIPTION

The pictures shown in this chapter are for illustrative purposes only.

5.1 Receiver description

5.1.1 R23-01, R23-03 (HOUSING 1)

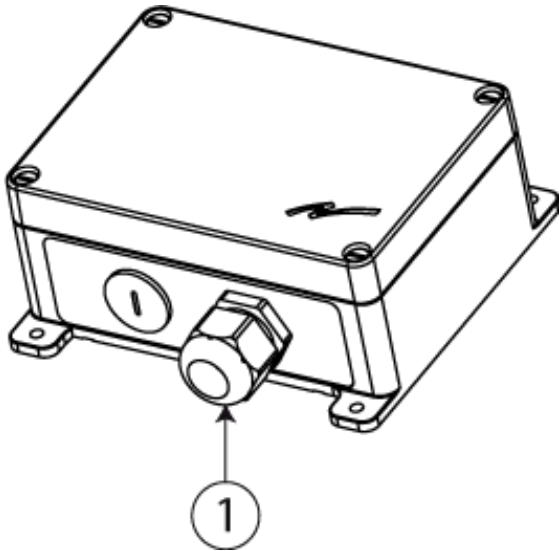

1. Power cable gland (M25x1.5)

5.1.2 R23-02, R23-04 (HOUSING 2)

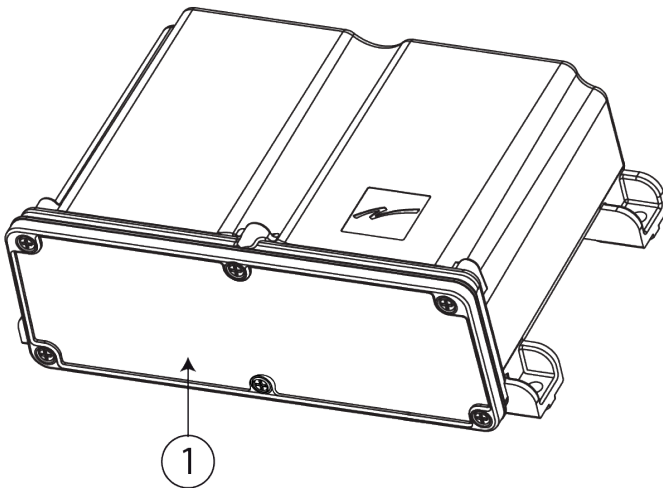

1. Customizable (e.g. Harting 10, 16 or 24 pin, or cable gland. Must be purchased separately).

5.2 Mechanical installation

5.2.1 R23-01, R23-03 (HOUSING 1)

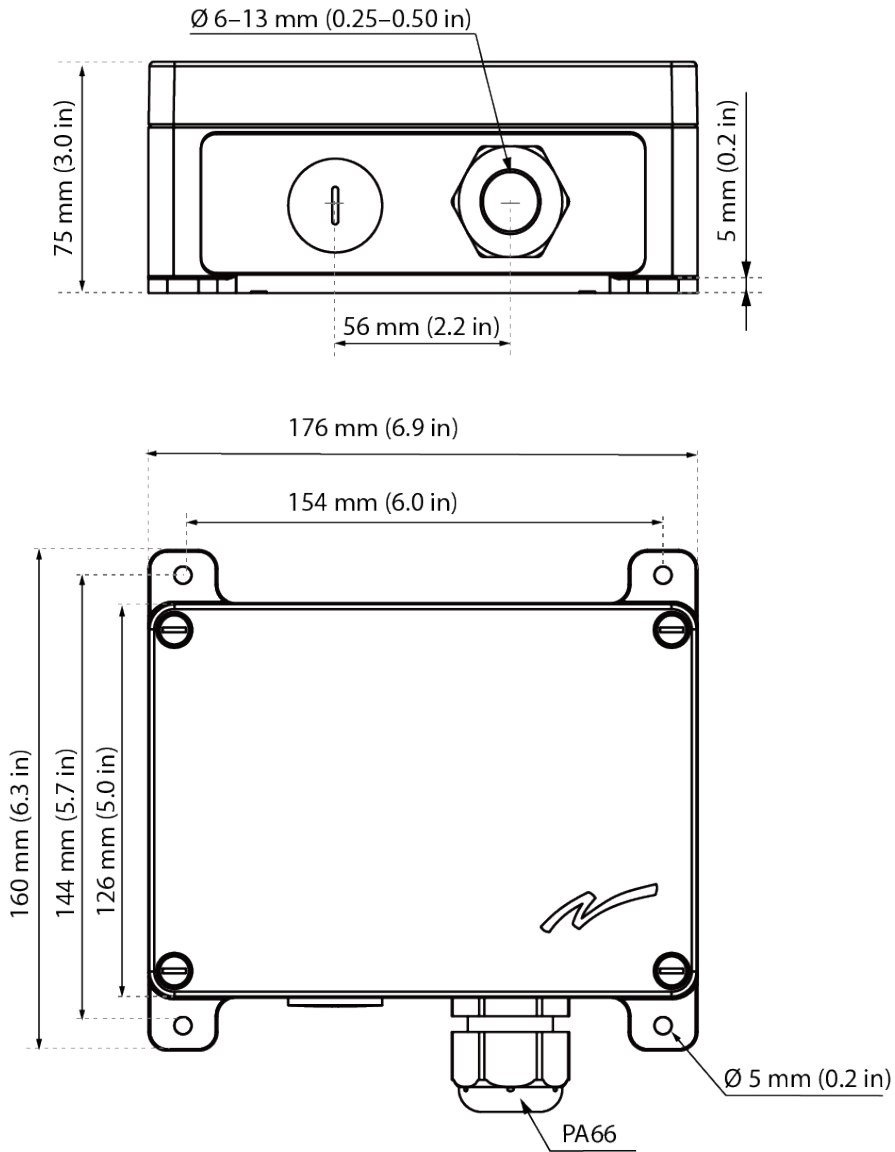

NOTE: For mounting on a wall or equipment, use 4 M5x30 mm screws or equivalent fastening method.

5.2.2 R23-02, R23-04 (HOUSING 2)

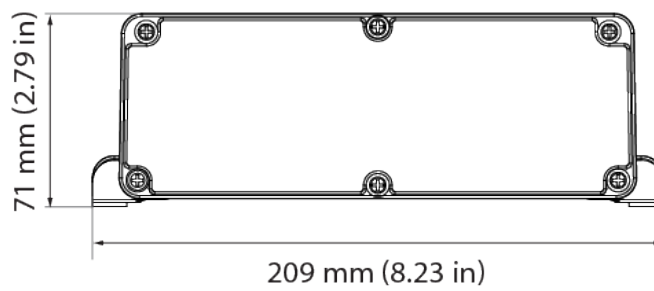
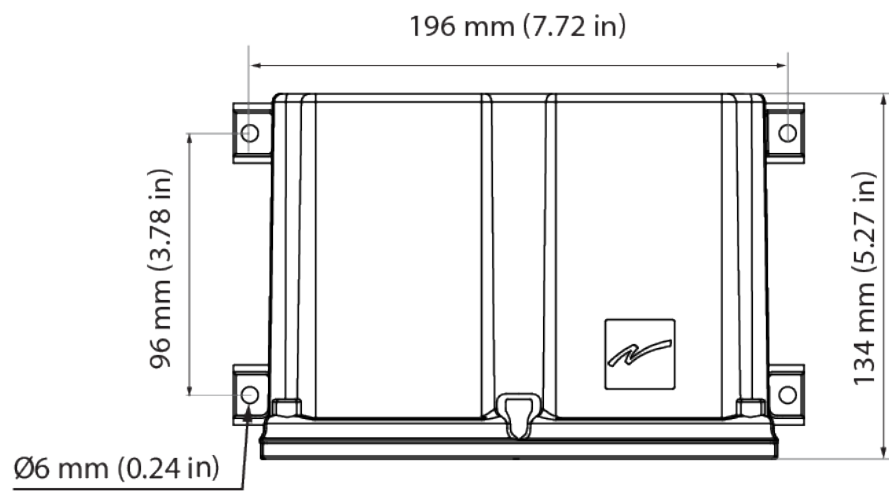

NOTE: For mounting on a wall or equipment, use 4 M5x30 mm screws or equivalent fastening method.

5.2.3 INSTALLATION PRECAUTIONS

RISK OF ELECTRIC SHOCK



The receiver must only be opened by qualified installers or authorized personnel.

Make sure the power supply is switched off before opening the receiver. Failure to follow these instructions could result in death, serious injury, or equipment damage.

IMPORTANT! Only authorized personnel should install the product.

Only correct installation complies with the safety levels for the product.

- A permanent installation of the receiver must include fuses in order to protect the equipment and cables from short circuit.
- The receiver must be installed vertically, on a flat and rigid surface, with the cable at the bottom.

NOTE: For mounting on a wall or equipment, use 4 M5x30 mm screws or equivalent fastening method.

- Install the receiver in a location where the LED is easily visible and the button accessible.
- Consider the wiring limitation and the radio communication limitation to choose the receiver location.
- Ensure no obstacle is impairing the radio communication performance between the receiver and the transmitter.
- The receiver must not be installed inside closed metal containers.
- Make sure any accessories inside or on the receiver are installed before permanently installing the receiver.
- Test the equipment before installing the receiver permanently.

5.3 Antenna

The wireless link can be used with up to four diversity antennas. As standard, R23 receivers are equipped with an internal antenna.

The internal antenna can operate at a distance of about 120 m but this working distance can change depending on many factors. Depending on the application and/or the environment, an additional external antenna or repeater can be added to R23 receivers to optimize data transmission.

Possible external antennas	1/2-2.4G	1/2-2.4G-K1
Possible repeaters	D5-21*	D5-22*

*For more details, please refer to the corresponding Installation instructions available on www.tele-radio.com.

5.3.1 EXTERNAL ANTENNA (OPTIONAL)

NOTE: If the cable length required is more than 5 m, using an active antenna is recommended.

Specifications

EXTERNAL ANTENNA	1/2-2.4G	1/2-2.4G-K1
Frequency	2405 –2480 MHz	2405 –2480 MHz
Current consumption	max. 500 mA	max. 500 mA
Impedance	50 Ω	50 Ω
Gain	3 dBi	3 dBi
Radiation	Omni	Omni
Connector	RP-SMA-K, female connector	SMA-J
Range	100 m (328 ft), adjustable depending on configuration	100 m (328 ft), adjustable depending on configuration
Dimensions	~ 19 x 114 x Ø10 mm / ~ 0.7 x 4.5 x 0.4 in	~ 117 mm / ~ 4.6 in
Weight without cable (typical).	~18 g (0.04 lbs)	~18 g (0.04 lbs)
IP code	IP40	IP40
Cable length	–	1 m / 3.2 ft

5.3.2 MOUNTING DIMENSIONS

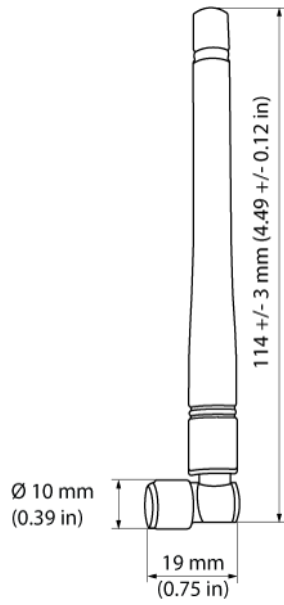

1/2-2.4G

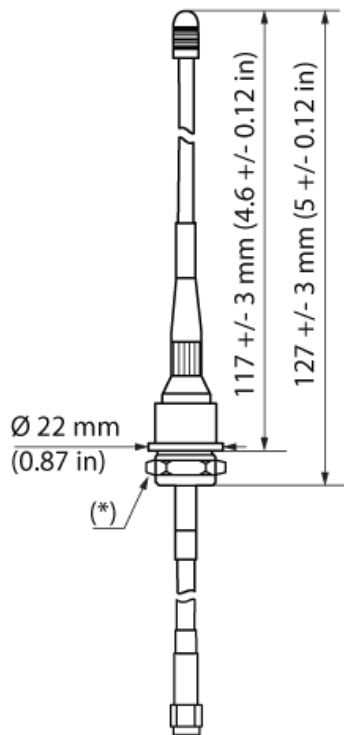

1/2-2.4G-K1

Mounting hole:

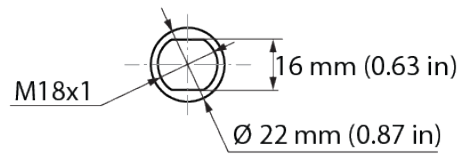

(*) Hex nut

5.3.3 PRECAUTIONS FOR THE INSTALLATION OF EXTERNAL ANTENNAS

IMPORTANT! Only authorized personnel should install the product.

Only correct installation meets the safety levels for the product.

- For optimum performance, place the external antennas away from metal objects such as metal girders, high-voltage cables, and other antennas.
- Keep the longest distance possible between the antenna and e.g. engines, welding machines, power sources, inverters, x-ray devices and other radio transmitters.
- Any antenna that is mounted separately must be positioned in as open a space as possible. A hidden antenna significantly impairs the reception.
- Do not mount the antenna in closed metal containers.
- Test the equipment before installing the antennas permanently.

CHAPTER 6: BOARD DESCRIPTION

NOTE: The pictures shown in this chapter are for illustrative purposes only.

RISK OF ELECTRIC SHOCK



The receiver must only be opened by qualified installers or authorized personnel.

Make sure the power supply is switched off before opening the receiver. Failure to follow these instructions could result in death, serious injury, or equipment damage.

IMPORTANT! Only experienced electronic technicians should add and map expansion boards and inputs/outputs.

6.1 Position of the printed circuit boards

Each board is identified by a position number. When referring to a component or a connector, use the board's position number together with the component number (engraved on the board) to make it easier for the support team to pinpoint the component or connector.

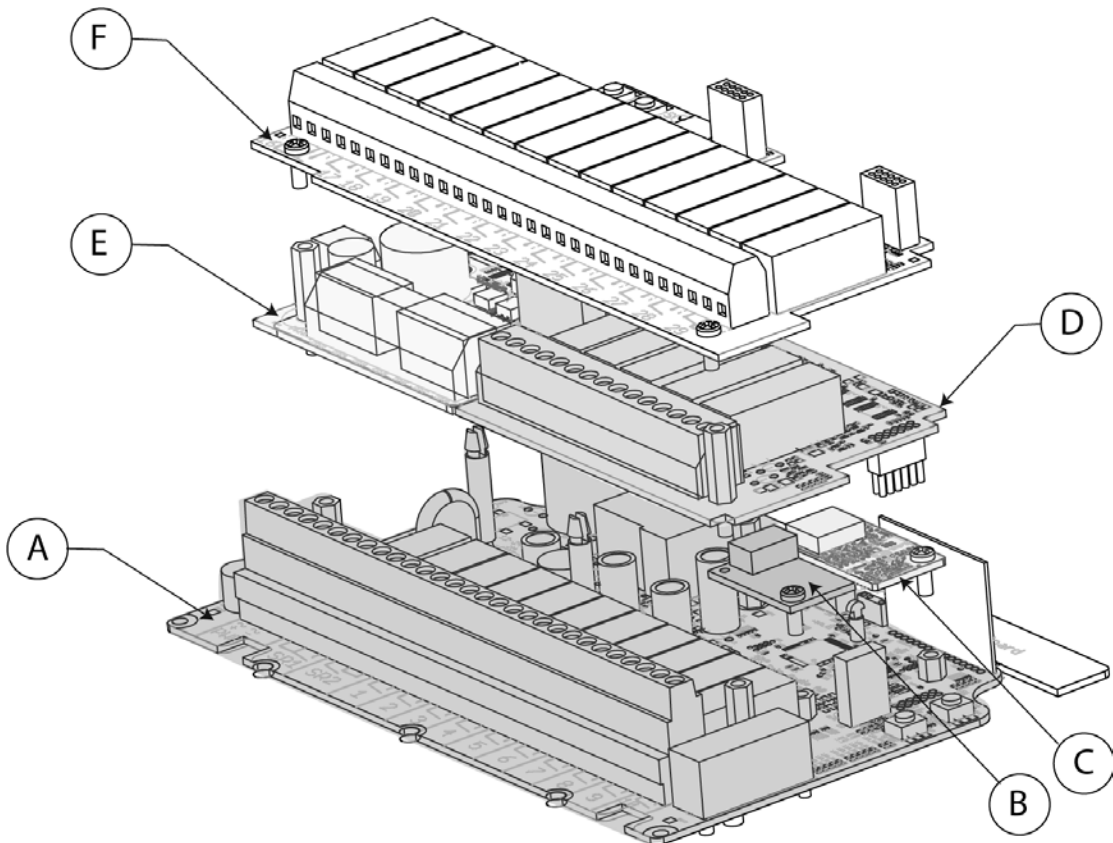

Board position number	Board description
A	Base board
B	RS485 expansion board
C	CAN expansion board
D	5-relay expansion board
E	DI expansion board
F	14-relay expansion board

6.2 Base board

NOTE: This base board is integrated in all R23 models. It has position number A.

IMPORTANT! Before connecting the power supply to the terminal block, make sure that J21 is connected to the connector corresponding to the power supply voltage (see "6.2.1 Power supply voltage").

NOTE: If the base board is powered with 48–230 V AC and used together with a CAN, RS485 or DI expansion board, use double insulated cables on both the power supply and relay terminal blocks.

The base board has two digital outputs. It can be fitted with up to five expansion boards.

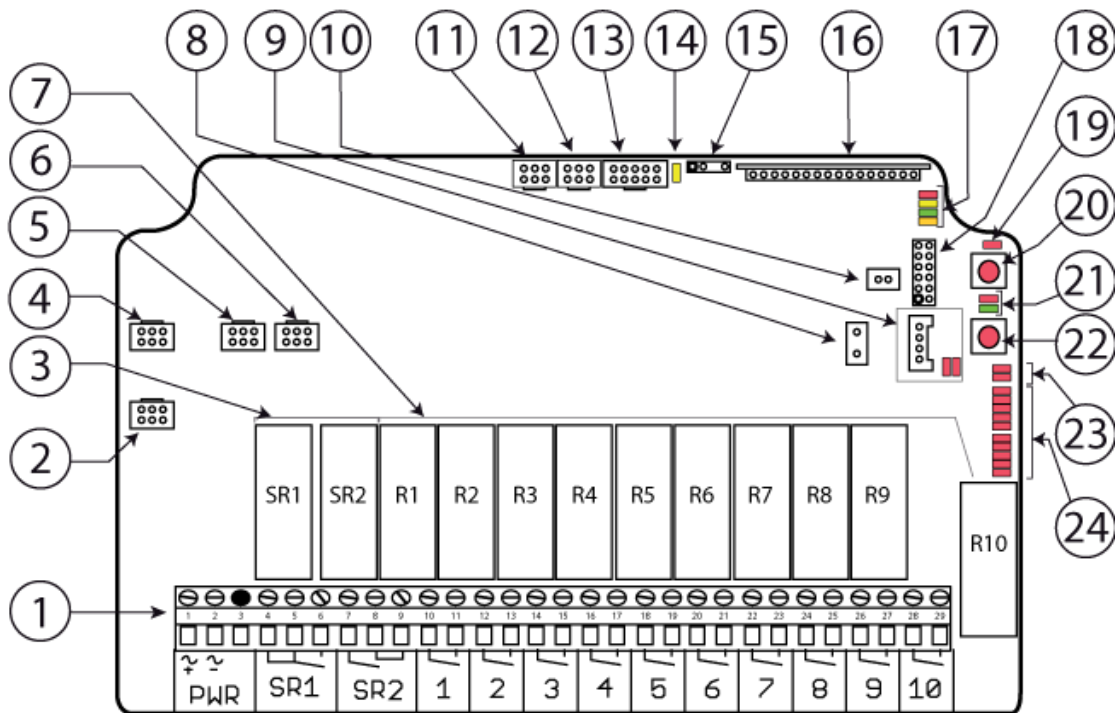

- | | |
|---|---|
| 1. Terminal block for power supply (PWR), stop relays (SR) and function relays* | 13. Connector for relay board ³ |
| 2. Connector for input power ¹ | 14. Power LED (yellow) |
| 3. Stop relays SR1–2 | 15. TRABUS contact |
| 4. Connector for 48–230 V AC | 16. Radio module 2.4 GHz |
| 5. Connector for 12–24 V AC/DC | 17. Function LEDs
(1 = red, 2 = yellow, 3 = green, 4 = orange) |
| 6. Connector for 12–24 V DC ² | 18. Connector for relay board ⁴ |
| 7. Function relays 1–10 (NO) | 19. PLd status LED (red) |
| 8. Connector for RS485 board | 20. Function button (Cancel) |
| 9. Connector and LEDs for DO 1–2 | 21. CANopen/J1939 status LEDs |
| 10. Connector for CANopen/J1939 board | 22. Select button (OK) |
| 11. Connector for DI board (CPU2) | 23. LED indicators for stop relays SR1–2 |
| 12. Connector for DI board (CPU1) | 24. Relay LEDs 1–10 (red) |

*By design, input power (PWR) is also connected to connector J21, see "6.2.1 Power supply voltage". For more information about cable requirements, see "6.2.2 Terminal block for power supply, stop and function relays on the base board".

¹To be connected to either J43, J44 or J45, depending on the voltage to achieve.

²Input to be used when the receiver needs to be able to go low in voltage.

³14-relay board.

⁴5-relay board.

6.2.1 POWER SUPPLY VOLTAGE

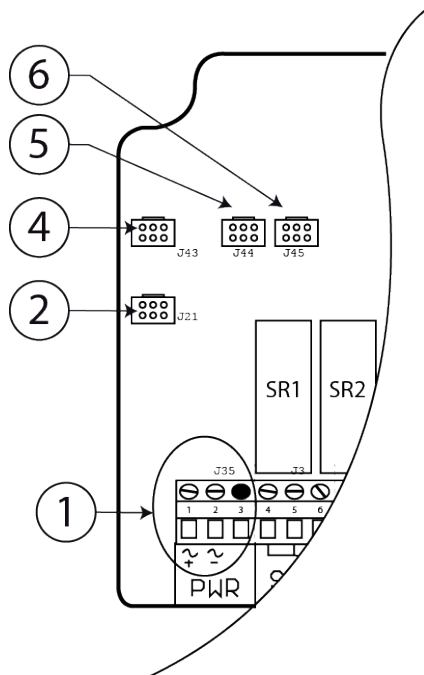

On this board, the terminal block for the power supply (1) is connected by design to the connector for input power (2) and there are three different connectors, one for each possible power supply voltage :

- (4) : **48-230 V AC**
- (5): **12-24 VAC/DC**
- (6): **12-24 V DC¹**

The power supply to the board must be connected in two steps:

1. Connect (2) to the connector corresponding to the desired power supply voltage.
2. Connect the external power supply to the PWR terminal block (1).

By default the receiver is supplied with the following connection.

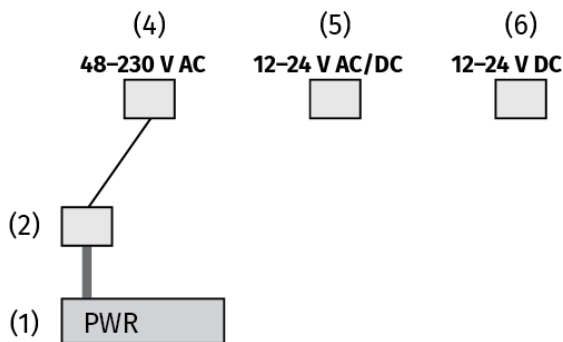

IMPORTANT! The connector for input power (2) must be connected to the correct power supply voltage connector (4), (5) or (6) BEFORE connecting the external power supply to the PWR terminal block (1).

¹Input to be used when the receiver needs to be able to go low in voltage.

6.2.2 TERMINAL BLOCK FOR POWER SUPPLY, STOP AND FUNCTION RELAYS ON THE BASE BOARD

NOTE: If input voltage is higher than 60 V DC or 30 V AC r.m.s, use double insulation cables on the power supply terminal block.

NOTE: If voltage on the function relay(s) is higher than 60 V DC or 30 V AC r.m.s, use double insulation cables on the relay terminal block.

NOTE: On J3–J20, use AWG12–24 cables.

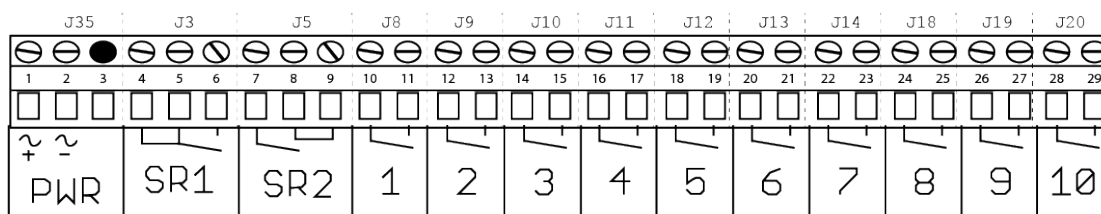

Relay number	Relay name	Terminal block	Pin number*	Contact
PWR	Power supply	J35	(A) 1	+
			(A) 2	-
			(A) 3	not used
SR1	Stop relay 1	J3	(A) 4	CO
			(A) 5	CO
			(A) 6	NO
SR2	Stop relay 2	J5	(A) 7	CO
			(A) 8	NO
			(A) 9	NO
1	Relay 1 (NO)	J8	(A) 10	CO
			(A) 11	NO
2	Relay 2 (NO)	J9	(A) 12	CO
			(A) 13	NO
3	Relay 3 (NO)	J10	(A) 14	CO
			(A) 15	NO
4	Relay 4 (NO)	J11	(A) 16	CO
			(A) 17	NO
5	Relay 5 (NO)	J12	(A) 18	CO
			(A) 19	NO
6	Relay 6 (NO)	J13	(A) 20	CO
			(A) 21	NO
7	Relay 7 (NO)	J14	(A) 22	CO
			(A) 23	NO
8	Relay 8 (NO)	J18	(A) 24	CO
			(A) 25	NO
9	Relay 9 (NO)	J19	(A) 26	CO
			(A) 27	NO
10	Relay 10 (NO)	J20	(A) 28	CO
			(A) 29	NO

*In parentheses is the position number of the expansion board.

6.2.3 CONNECTOR FOR DIGITAL OUTPUTS ON THE BASE BOARD

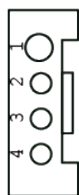

1. +5 V
2. Digital output 1*
3. Digital output 2*
4. GND

*Open drain, max. voltage 30 V, max. current 100 mA.

6.3 Expansion boards

Expansion boards can be used to increase the number of inputs/outputs and communication options. There are currently three expansion boards available for the R23 receivers.

EXPANSION BOARDS	Available slots on the base board
14-relay expansion board	1
5-relay expansion board	1
Expansion board for digital inputs	1
CAN expansion board	1
RS485 expansion board	1

6.3.1 5-RELAY EXPANSION BOARD

NOTE: This relay expansion board is integrated in the following receiver models: R23-03, R23-04, R23-11. It has position number D.

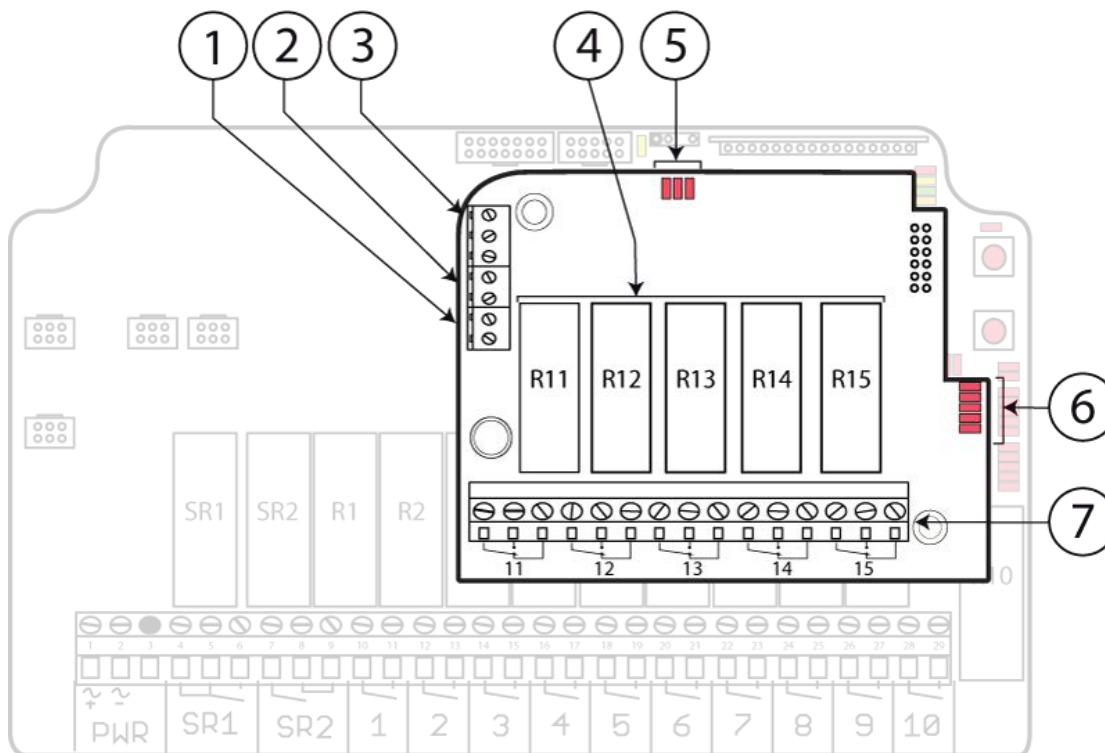

- | | |
|--|---|
| 1. Terminal block for +3.3 V/ GND | 5. Status LEDs for DO 3-5 |
| 2. Terminal block for +5-12 V | 6. Relay LEDs 11-15 (red) |
| 3. Terminal block for DO 3-5 | 7. Terminal blocks for function relays 11-15* |
| 4. Function relays 11-15 (change-over) | |

*For more information about cable requirements, see " Terminal blocks for function relays 11-15 on the 5-relay expansion board".

Terminal blocks for function relays 11–15 on the 5-relay expansion board

NOTE: If voltage on the function relay(s) is higher than 60 V DC or 30 V AC r.m.s, use double insulation cables on the relay terminal block.

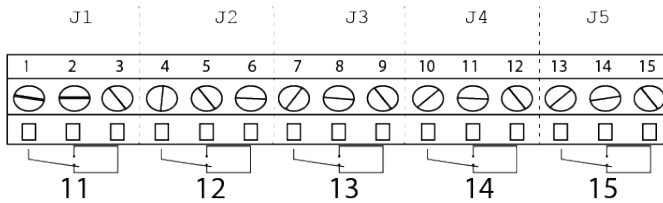

NOTE: On J3–J5, use AWG12-24 cables.



Relay number	Relay name	Terminal block	Pin number*	Contact
11	Function relay 11	J1	(D) 1	CO
			(D) 2	NO
			(D) 3	NC
12	Function relay 12	J2	(D) 4	CO
			(D) 5	NO
			(D) 6	NC
13	Function relay 13	J3	(D) 7	CO
			(D) 8	NO
			(D) 9	NC
14	Function relay 14	J4	(D) 10	CO
			(D) 11	NO
			(D) 12	NC
15	Function relay 15	J5	(D) 13	CO
			(D) 14	NO
			(D) 15	NC

*In parentheses is the position number of the expansion board.

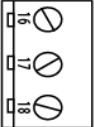
Terminal blocks for digital outputs on the 5-relay expansion board

		Pin number*	Description
	J6	(D) 16	Digital output 3 **
		(D) 17	Digital output 4 **
		(D) 18	Digital output 5 **
	J7	(D) 19	+12 V DC
		(D) 20	+5 V DC
	J8	(D) 21	+3.3 V DC
		(D) 22	GND

*In parentheses is the position number of the expansion board.

**Open drain, max. voltage 30 V, max. current 100 mA.

6.3.2 14-RELAY EXPANSION BOARD

NOTE: This relay expansion board is integrated in the following receiver models: R23-11, R23-12. It has position number F.

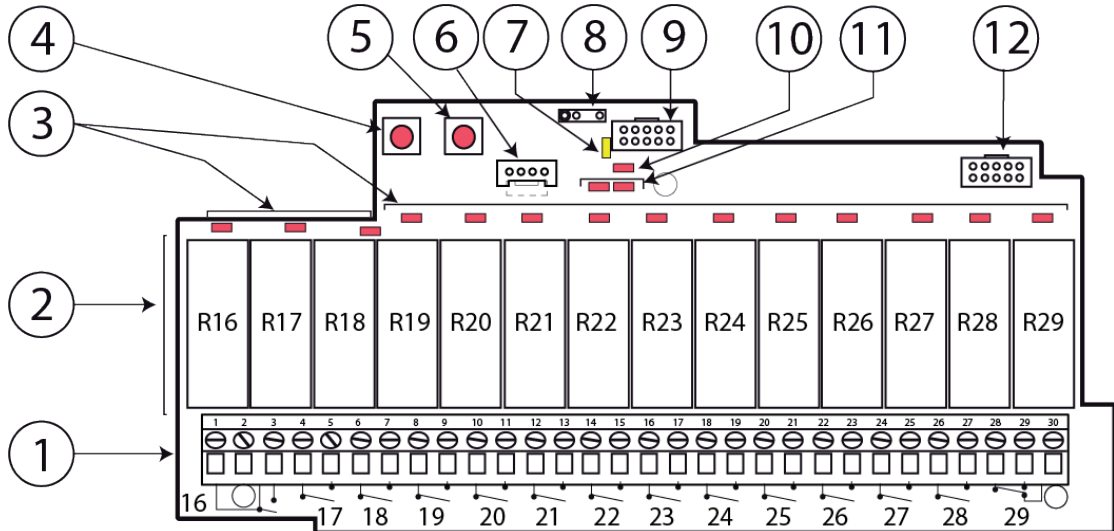

- | | |
|---|-------------------------------|
| 1. Terminal blocks for function relays 16-29* | 7. Function LED 1 (yellow) |
| 2. Function relays 16-28 (NO) and 29 (NO/NC) | 8. TRABUS contact |
| 3. Relay LEDs 16-29 (red) | 9. Connector for base board |
| 4. Function button (Cancel) | 10. Function LED 2 (red) |
| 5. Select button (OK) | 11. Status LEDs for DO DO 6-7 |
| 6. Connector for DO 6-7 | 12. Connector for AI 1-8 |

*For more information about cable requirements, see " Terminal blocks for function relays 16-29 on the 14-relay expansion board".

Terminal blocks for function relays 16–29 on the 14-relay expansion board

NOTE: If voltage on the function relay(s) is higher than 60 V DC or 30 V AC r.m.s, use double insulation cables on the relay terminal block.

NOTE: On J3–J16, use AWG12-24 cables.

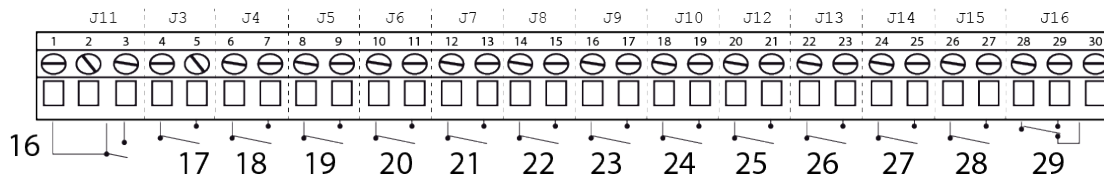

Relay number	Relay name	Terminal block	Pin number*	Contact
16	Function relay 16	J11	(F) 1	CO
			(F) 2	CO
			(F) 3	NO
17	Function relay 17	J3	(F) 4	CO
			(F) 5	NO
18	Function relay 18	J4	(F) 6	CO
			(F) 7	NO
19	Function relay 19	J5	(F) 8	CO
			(F) 9	NO
20	Function relay 20	J6	(F) 10	CO
			(F) 11	NO
21	Function relay 21	J7	(F) 12	CO
			(F) 13	NO
22	Function relay 22	J8	(F) 14	CO
			(F) 15	NO
23	Function relay 23	J9	(F) 16	CO
			(F) 17	NO
24	Function relay 24	J10	(F) 18	CO
			(F) 19	NO
25	Function relay 25	J12	(F) 20	CO
			(F) 21	NO
26	Function relay 26	J13	(F) 22	CO
			(F) 23	NO
27	Function relay 27	J14	(F) 24	CO
			(F) 25	NO
28	Function relay 28	J15	(F) 26	CO
			(F) 27	NO
29	Function relay 29	J16	(F) 28	CO
			(F) 29	NO
			(F) 30	NC

*In parentheses is the position number of the expansion board.

Connector for digital outputs on the 14-relay expansion board

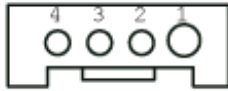

1. +5 V
2. Digital output 7 *
3. Digital output 6 *
4. GND

*Open drain, max. voltage 30 V, max. current 100 mA.

Connector for analog inputs on the 14-relay expansion board

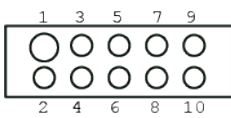

- | | |
|--------------------|---------------------|
| 1. GND | 6. Analog input 6* |
| 2. Analog input 2* | 7. Analog input 5* |
| 3. Analog input 1* | 8. Analog input 8* |
| 4. Analog input 4* | 9. +5 V DC |
| 5. Analog input 3* | 10. Analog input 7* |

*Not implemented.

6.3.3 EXPANSION BOARD FOR DIGITAL INPUTS

NOTE: This relay expansion board is integrated in the following receiver model: R23-11. It has position number E.

This expansion board allows to connect up to eight digital inputs. For more inputs, contact your representative for assistance.

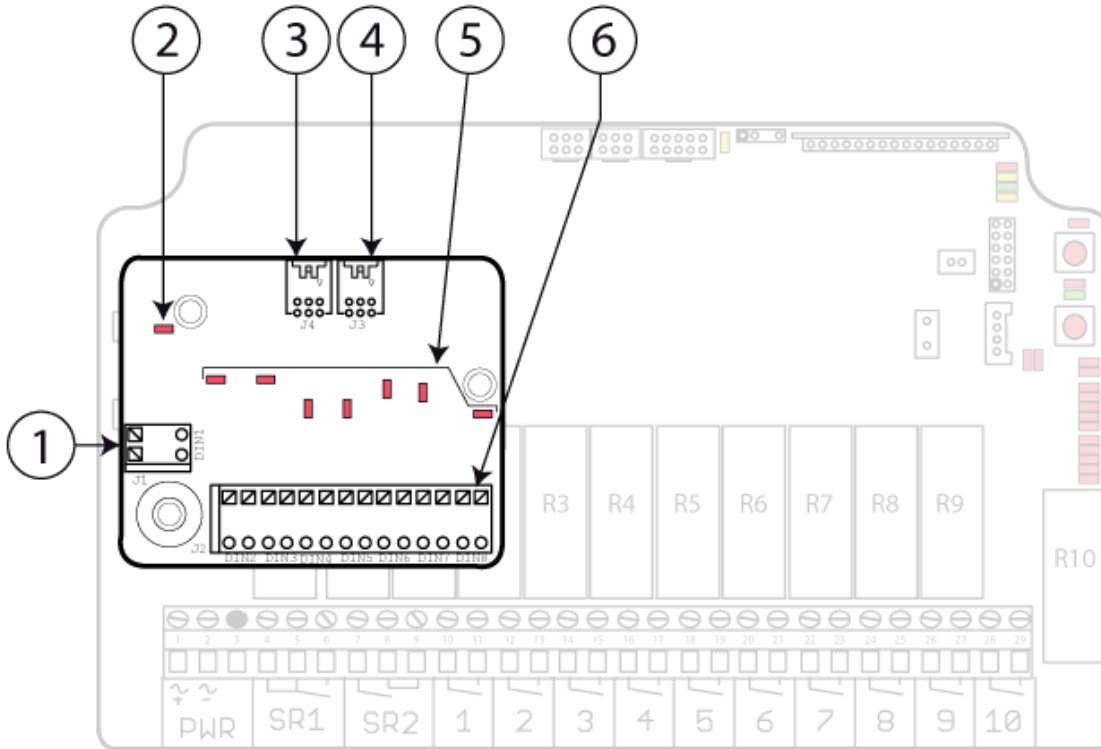

- | | |
|---------------------------------|---------------------------------|
| 1. Terminal block for DI 1 | 4. Connector for the base board |
| 2. Status LED for DI 1 | 5. Status LED for DI 2–8 |
| 3. Connector for extra DI board | 6. Terminal block for DI 2–8 |

Terminal blocks for digital inputs on the DI expansion board

NOTE: Each digital input has two pins. The pins are interchangeable and can be used either as DI or as GND.

NOTE: 9–33 V DC or 8–24 V AC, max. current 10 mA for each digital input.

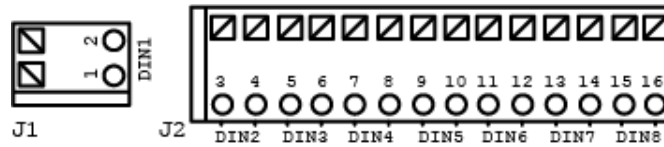

J1 – Digital inputs 1

Pin number*	Description	Pin number*	Description
(E) 1	Digital input 1	(E) 1	GND
(E) 2	GND	(E) 2	Digital input 1

J2 – Digital inputs 2–8

Pin number*	Description	Pin number*	Description
(E) 3–4	Digital input 2 / GND	(E) 11–12	Digital input 6 / GND
(E) 5–6	Digital input 3 / GND	(E) 13–14	Digital input 7 / GND
(E) 7–8	Digital input 4 / GND	(E) 15–16	Digital input 8 / GND
(E) 9–10	Digital input 5 / GND		

*In parentheses is the position number of the expansion board.

Wiring examples

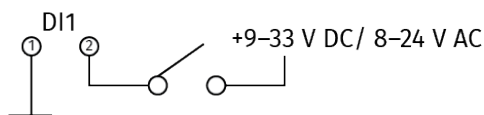

Fig. 1: Pin1 to GND, pin 2 to input voltage

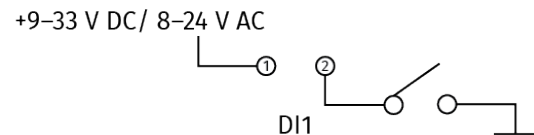
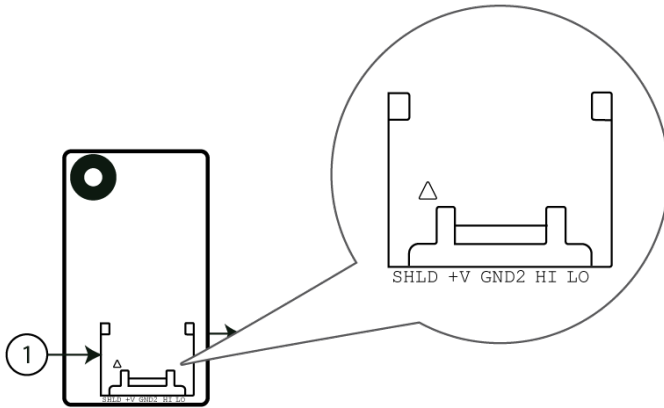

Fig. 2: Pin 1 to input voltage and pin2 to GND

6.3.4 CAN EXPANSION BOARD

NOTE: This relay expansion board is integrated in the following receiver models: R23-08, R23-09. It has position number C.



1. CAN connector.

NOTE: V+ is not used.

6.3.5 RS485 EXPANSION BOARD

NOTE: This relay expansion board is integrated in the following receiver models: R23-08, R23-09. It has position number B.

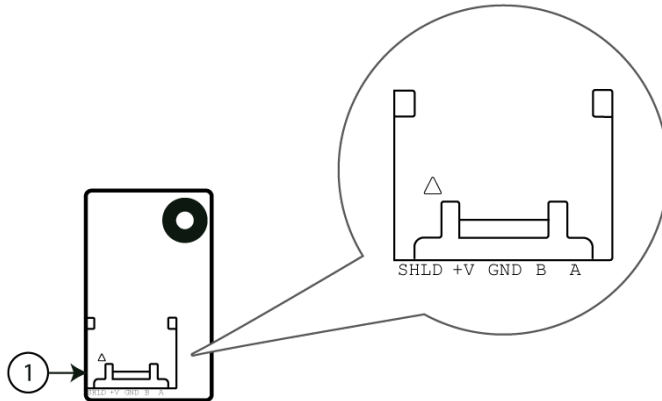

1. RS485 connector.

NOTE: The voltage (+V) is internally connected to VIN on the base board (input power supply). Maximum current consumption: 1 A

CHAPTER 7: STATUS AND ERROR INDICATIONS

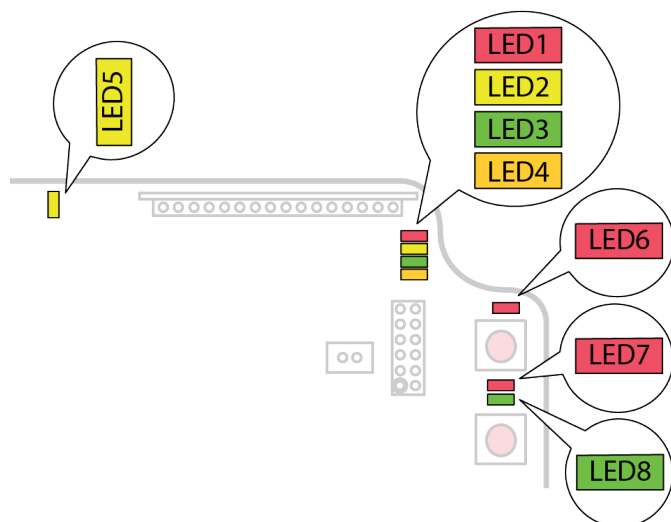

7.1 Function LEDs indication in normal operation

LED	Color	Off	On	Flashing	Indicates
5	yellow	○			No power to the receiver
			●		Receiver is powered up
6	red		●		Not compliant with PLd
		○			Compliant with PLd
1	red	○			No transmitter is registered.
			●	Single flash	One or more transmitters are registered. No radio link.
			●	Double flash	One or more transmitters are registered and logged in. No radio link.
			●	Solid	Radio link established.
2	yellow		●		Receiving a radio packet from a transmitter other than a Panther.
2 3	yellow green		● ●		Receiving a radio packet from a transmitter set to a different radio mode (discontinuous or continuous) than the receiver.
2 4	yellow orange		● ●		Receiving a radio packet from a transmitter that is not registered.
3	green		●		Receiving a radio packet, low signal (RSSI).
4	orange		●		Receiving a radio packet, configuration ID not accepted.

LED	Color	Off	On	Flashing	Indicates
3 4	green orange		● ●		Receiving a radio packet, custom ID not accepted.
2 3 4	yellow green orange		● ● ●		1. Receiving a radio packet from a registered transmitter. The receiver is already controlled by another registered transmitter. 2. Load select mode is activated. Incorrect Load is selected on the transmitter.
1-4	red yellow green orange		● ● ● ●		TRABUS mode activated (PC communication).

7.2 CANopen run status (LED8)

LED color	On	Flickering (red/ green alternately)	Single flash	Blinking
Green	Operational state	LSS	Stopped state	Pre-operational state

CANopen communication state	Description
Operational	State for process data transmission.
LSS	LSS services in progress.
Stopped	Except for node guarding or heartbeat messages, a node cannot transmit or receive any other messages in this state.
Pre-operational	State for the configuration of CANopen devices. PDO communication is not possible in this state.

7.3 CANopen error status (LED7)

LED color	On	Flickering (red/ green alternately)	Single flash	Double flash	Triple flash
Red	Bus off	LSS	Warning limit reached	Error control event	Sync error

CANopen error code message	Problem description
Bus Off	CAN controller is in bus off.
Warning limit reached	At least one of the error counters in the CAN controller has reached or exceeded its warning level (e.g. too many error frames).
Error Control Event	A guard event or a heartbeat event has occurred.
Sync Error	The sync message has not been received within the configured communication cycle time.
LSS	LSS services in progress.

7.4 J1939 run status (LED8)

LED color	On	Single flash
Green	Operational	No address

J1939 communication state	Description
Operational	Address claim is correct, processing messages.
No address	Address claim is still running or has failed.

7.5 J1939 error status (LED7)

LED color	On	Single flash
Red	Bus off	Warning limit reached

J1939 error code message	Problem description
Bus Off	CAN controller is in bus off.
Warning limit reached	At least one of the error counters in the CAN controller has reached or exceeded its warning level (e.g. too many error frames).

7.6 Menu mode indications

The different menus are identified by the Function LEDs 1–4 according to the following table.

●: LED is lit. ○: LED is off.

Function LEDs				Menu
LED 1 (red)	LED 2 (yellow)	LED 3 (green)	LED 4 (orange)	
●	○	○	○	Register/ erase transmitters
○	●	○	○	Latching/ momentary relay functions
○	○	●	○	Show settings
○	○	○	●	Show/ change Operating mode
○	○	●	●	Active Load select (extended menu)

7.7 Error indications and code messages

Errors are indicated by function LEDs 1–4, which are all flashing at the same time.

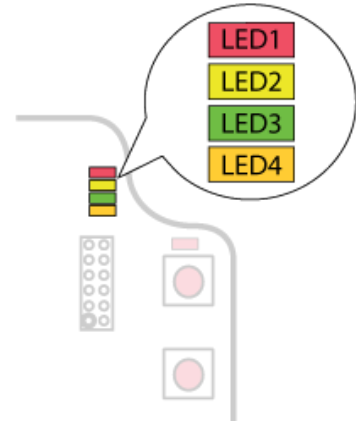

Each error is identified by a code indicated by relay LEDs 1–10.

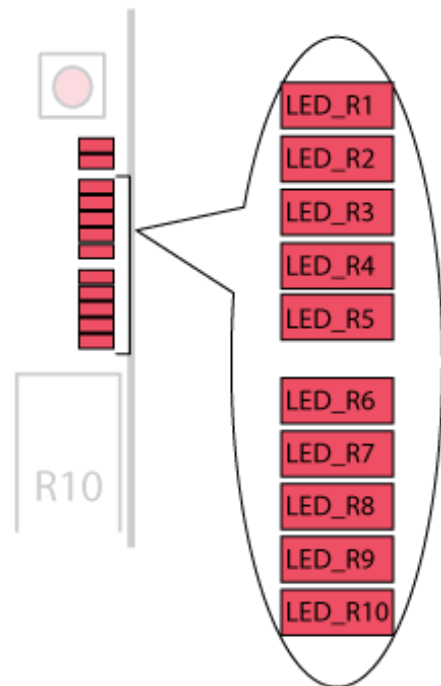

Write down which relay LED(s) are lit and contact your representative for assistance.

●: LED is lit. ○: LED is off.

Relays LEDs (LED_...)										Description	Recommended corrective action
R1	R2	R3	R4	R5	R6	R7	R8	R9	R10		
red	red	red	red	red	red	red	red	red	red		
○	○	○	○	●	○	○	○	○	○	For this error code, contact technical support	
○	○	○	●	○	○	○	○	○	○	For this error code, contact technical support	

Relays LEDs (LED_...)										Description	Recommended corrective action	
R1	R2	R3	R4	R5	R6	R7	R8	R9	R10			
red	red	red	red	red	red	red	red	red	red	red		
○	●	○	●	●	○	○	○	○	●		Overcurrent error on the analog output exp. board.	The digital output(s) on Analog output exp. board have suffered a short-circuit. Investigate and remove the possible causes. If the error persists, contact technical support.
○	●	○	●	●	○	○	○	●	○		The connection between the 14-relay exp. board and CPU1 has been lost.	Restore the connection, e.g. connect the board again or check the cable.
○	●	○	●	●	○	○	○	●	●		The connection between the 5-relay exp. board and CPU1 has been lost.	Restore the connection, connect the board again or check the cable. If the error persists, contact technical support.
○	●	○	●	●	○	○	●	○	○		The connection between the DI expansion board (s) and CPU1 has been lost (at least one DI expansion board was connected to CPU1, but all are now disconnected)	Restore the connection, e.g. connect the board(s) again or check the cables. If the error persists, contact technical support.
○	●	○	●	●	○	○	●	○	●		The connection between the AN/DI exp. board and CPU1 has been lost.	Restore the connection, e.g. connect the board(s) again or check the cables. If the error persists, contact technical support.
○	●	○	●	●	○	○	●	●	○		AN/DI exp. board detected (connected) but the receiver is not in Operation mode 255	Remove the AN/DI exp. board or change to operating mode 255 in the receiver.
○	●	○	●	●	○	○	●	●	●		Software incompatibility error on the 14-relay exp. board	Update the software.
○	●	○	●	●	○	●	○	○	○		The 14-relay exp. board seems to be in bootloader. Something that does not respond is connected.	Flash the 14-relay exp. board. If the error persists, contact technical support.
●	○	○	○	○	○	○	○	○	○		'Safe settings' write error. Normal indication that occurs before a 'safe setting' has been approved by the user.	Approve the 'safe setting' in SM.

CHAPTER 8: OPERATION

8.1 General information

8.1.1 RECEIVERS WITH LOGIN/LOGOUT¹ FUNCTION ACTIVATED

To control a receiver, the transmitter must be registered and logged in to the receiver. If another transmitter is already logged in to the receiver, it must be logged out before a different transmitter can be logged in.

If no transmitter is logged in to the receiver, the first registered transmitter to be started will automatically log in to the receiver. Once a transmitter has been logged in, it will remain logged in until it is manually logged out.

More than one transmitter can be registered in the receiver, but only one transmitter can be logged in at a time.

8.1.2 RECEIVERS WITHOUT LOGIN/LOGOUT FUNCTION OR WITH LOGIN/LOGOUT FUNCTION INACTIVATED

To control a receiver, the transmitter must be registered in the receiver.

If no transmitter is controlling the receiver, the first registered transmitter to be started will automatically take control of the receiver. Switching the transmitter off will free the receiver and allow any other registered transmitter that is started to control the receiver.

More than one transmitter can be registered in the receiver, but only one transmitter can control the receiver at a time.

NOTE: If the login/logout function is inactivated the receiver is not PLd compliant.

8.1.3 MULTIPLE TRANSMITTERS REGISTERED IN A SAME RECEIVER

If more than one transmitter is registered in the same receiver, it is recommended to select the same frequency channel on all transmitters.

¹For more information about login/logout, see "8.4 Login/logout function"

8.2 Radio mode

The radio mode is determined by the selected **Operating mode**.

To establish a radio link between the transmitter and the receiver, both units must be set to the same radio mode.

This receiver is set to **continuous** radio mode by default.

Some settings can only be selected when the products are transmitting continuously. These settings are indicated with the note "Only for continuous radio mode."

8.3 Relay functions

This receiver is set to momentary relay functionality by default. The relay remains active while a button is pressed on the transmitter. When the button is released the relay deactivates. Setting a relay to latching means that the relay becomes active when a button is pressed and remains active until the button is pressed again.

8.4 Login/logout function

NOTE: Only for **continuous** radio mode.

NOTE: The login/logout function cannot be activated/deactivated in the receiver. Contact your representative for assistance.

For this receiver, the login/logout function is activated by default.

Logging out means stopping the communication between the transmitter and the receiver, and freeing the receiver for another registered transmitter to log in.

CHAPTER 9: CONFIGURATION MENU

All configuration settings require access to the receiver circuit board(s).



RISK OF ELECTRIC SHOCK

The receiver must only be opened by qualified installers or authorized personnel.

Make sure the power supply is switched off before opening the receiver.

Failure to follow these instructions could result in death, serious injury, or equipment damage.

1. Remove the front cover of the receiver. Use a screwdriver to remove the screws.
2. Power the receiver up.
3. The power LED lights (yellow).
4. Proceed with the configuration instructions of your choice.

9.1 Menu mode

To select the different menus, press the **Function** button a predefined number of times according to the following table. Press the **Select** button to enter.

The different menus are identified by the function LEDs 1–4 (see "6.2 Base board").

●: LED is lit. ○: LED is off.

Menu	To select the menu, press the Function button...	Function LEDs light			
		LED 1 (red)	LED 2 (yellow)	LED 3 (green)	LED 4 (orange)
Register/Erase transmitters	once	●	○	○	○
Show/Change latching/momentary functions	2 times	○	●	○	○
Show settings	3 times	○	○	●	○
Show/Change Operating mode	4 times	○	○	○	●
Active Load select (extended menu)	5 times and keep pressed until LED3–4 light.	○	○	●	●

9.2 Register the transmitter in the receiver



RISK OF UNINTENDED EQUIPMENT OPERATION

Only transmitters that are intended for use should be registered in the receiver.

Failure to follow these instructions could result in death, serious injury, or equipment damage.



RISK OF UNINTENDED EQUIPMENT OPERATION

Do not perform this action when the receiver is in a session with another transmitter. The radio communication may be interrupted or broken.

Failure to follow these instructions could result in death, serious injury, or equipment damage.

NOTE: To establish a radio link between the transmitter and the receiver, both units must be set to the same radio mode.

1. Set the transmitter in registration mode (see relevant Tele Radio transmitter installation instructions).
2. Press the **Function** button.
Function LED 1 lights (red).
3. Press the **Select** button.
All relay LEDs light (red).
4. Press both **Start** buttons on the transmitter to be registered in the receiver (see relevant Tele Radio transmitter installation instructions).
All function LEDs light.
5. Release the transmitter buttons.

If the transmitter is registered, all relay LEDs flash 3 times.

If no transmitter is found within approximately 10 seconds, the receiver exits to normal operation.

9.3 Set momentary or latching relay functions

The settings options depend on the selected **Operating mode**.

NOTE: The number of relays that can be set to latching varies depending on the selected **Operating mode**.

NOTE: It is not possible to program latching relays in Operating mode 255.

1. Press the **Function** button twice.
Function LED 2 lights (yellow). The lit relay LEDs indicate relays set to latching.
2. Press the **Select** button to enter the setting mode.
The relay LED for the first available relay flashes fast.
3. Press the **Function** button to change the setting for the current relay. Relays can be set to latching or momentary and the current setting is indicated by function LED 2 (yellow).
●: LED is lit. ○: LED is off.

Function LED 2	Indicates
○	Momentary
●	Latching

4. Press the **Select** button to confirm the setting and move to the next available relay.
5. Repeat steps 3–4 for all available relays.

After the last relay has been programmed (depending on operating mode and hardware configuration), the receiver returns to normal operation.

9.4 Show settings

1. Press the receiver **Function** button three times.

Function LED 3 lights (green).

2. Press the **Select** button.

The relay LEDs 1–4 indicate the current settings according to the following table:

Relay LED	Color	Off	On	Indicates
LED_R1	red	○		Discontinuous transmitting mode
			●	Continuous transmitting mode
LED_R2	red	○		Custom ID not enabled
			●	Custom ID enabled
LED_R3	red	○		Configuration ID not enabled
			●	Configuration ID enabled
LED_R4	red	○		Frequency scan on
			●	Frequency scan off (fixed frequency)

After approximately 10 seconds, the receiver will automatically exit "Show Settings" mode and return to normal operation.

9.5 Operating modes

This receiver is provided with four **Operating modes** as standard (1, 2, 3 and 255). For other **Operating modes**, contact your representative for assistance.

NOTE: If operating mode 255 has been selected, it is not possible to change the **Operating mode** from the receiver.

9.5.1 SHOW/ CHANGE OPERATING MODE



RISK OF UNINTENDED EQUIPMENT OPERATION

Do not perform this action when the receiver is in a session with another transmitter. The radio communication may be interrupted or broken. Failure to follow these instructions could result in death, serious injury, or equipment damage.

1. Press the **Function** button four times.

*Function LED 4 lights (orange). The relay LEDs indicate the current **Operating mode** according to the table below:*

relay LED 1	relay LED 2	relay LED 3	relay LED 4	Operating mode	Radio mode
●	○	○	○	1 (default)	Continuous mode
○	●	○	○	2	Continuous mode
●	●	○	○	3	Continuous mode
●	●	●	●	255	Continuous/ discontinuous depending on the settings

NOTE: If no button is pressed within approximately 10 seconds, the receiver will automatically return to normal operation.

To change **Operating mode:**

2. Press the **Select** button.

Function LED 4 flashes (orange).

3. Press the **Function** button once to move to the next available **Operating mode** (repeat until the LED combination corresponds to the desired **Operating mode**).

The corresponding relay LEDs lights.

4. Press the **Select** button to confirm.

The new configuration is saved. The receiver returns to normal operation.

9.5.2 OPERATING MODE 1

NOTE: Only for **continuous** radio mode.

NOTE: If the radio link is lost, all relays and digital outputs will switch off.

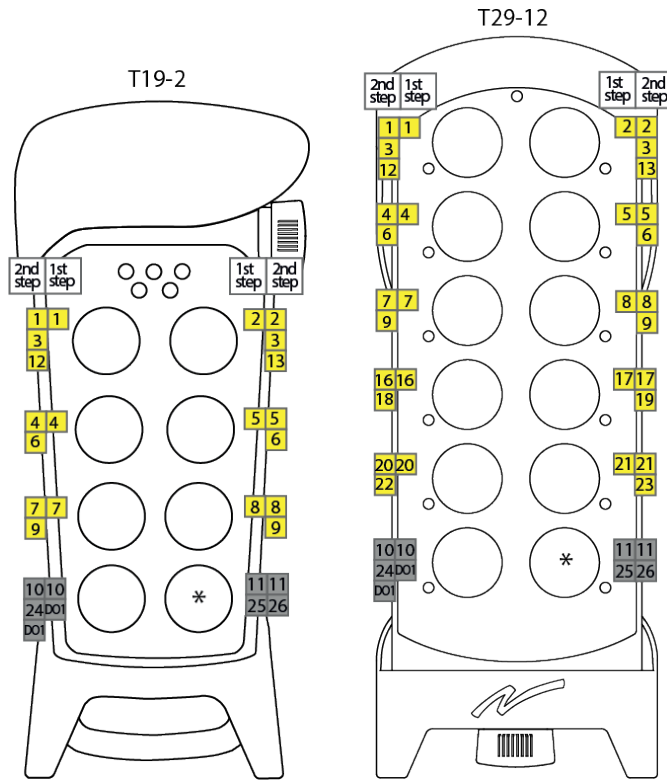

- 2 Relay number on the receiver
- Button functions
- Direction functions
- * Depending on the Load select mode selected on the transmitter.

On relays	Stop relays (SR1 + SR2) and DO2 are active when the radio link is up.
Work relays	Relay 29 should be activated if any of the transmitter buttons are pressed.
Load select relays	Load A: relay 14 + 27 Load B: relay 15 + 28
Programmable relay functions	Relay 10 and 11, 24–26 can be set to latching or momentary.
Interlocking	Between button pairs 1–2, 3–4, 5–6
Radio mode	Continuous
Zero position check	Active for all functions/buttons.

Digital outputs	DO1: e.g. for a +5 V buzzer
	DO2: +5 V bright LED to indicate that the stop relays are activated.
	DO3-7: N/A

9.5.3 OPERATING MODE 2

NOTE: Only for **continuous** radio mode.

NOTE: If the radio link is lost, all relays and digital outputs will switch off.

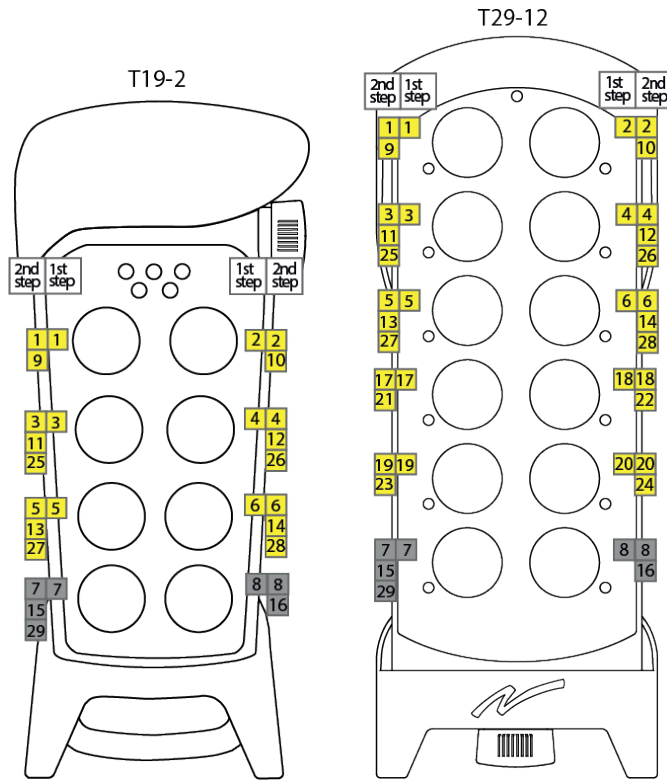

- 2 Relay number on the receiver
- Button functions
- Direction functions

On relays	Stop relays (SR1 + SR2) are active when the radio link is up.
Work relays	–
Load select relays	–
Programmable relay functions	Relays 1–29 can be set to latching or momentary.
Interlocking	No interlocking between relay outputs. All buttons are used as button functions.
Radio mode	Continuous
Zero position check	Active for all functions/buttons.
Digital outputs	DO1–7 not used.

9.5.4 OPERATING MODE 3

NOTE: Only for **continuous** radio mode.

NOTE: If the radio link is lost, all relays and digital outputs will switch off.

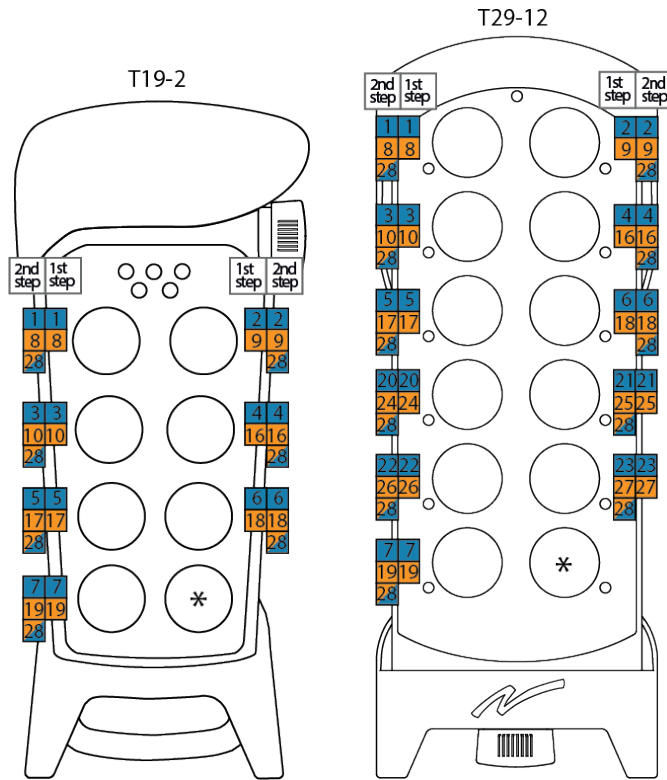

- 2 Relay number on the receiver
- Button function – Load select A (relay 11 for indication)
- Button function – Load select B (relay 12 for indication)
- * Depending on the Load select mode selected on the transmitter.

On relays	Stop relays (SR1 + SR2) are active when the radio link is up.
Work relays	Relays 13–15: not used. Relay 28: Engine RPM increase with 500 ms delay when releasing. Relay 29: active when relays 1–10 and 16–27 are activated.
Load select relays	Load A: relay 11 Load B: relay 12
Programmable relay functions	Relays 1–10 and 16–27 can be set to latching or momentary.

Interlocking	No interlocking between relay outputs. All buttons are used as button functions.
Radio mode	Continuous
Zero position check	Active for all functions/buttons.
Digital outputs	DO1-7 not used.

9.6 Active Load select

NOTE: If this setting is set to 0 (status LEDs 1–4 are off), the receiver will always be activated when receiving a radio package. For all other settings, the receiver will be activated when the load select on the transmitter corresponds to one of the load select settings enabled in the receiver.

9.6.1 SHOW LOAD SELECT

1. Press the **Function** button five times and keep it pressed until function LEDs 4 (orange) and 3 (green) light.

*The receiver is now in extended menu mode. Relay LEDs 1–4 show the current **Load select** setting according to the table below:*

●: LED is lit. ○: LED is off.

Relay LED 1 (red)	Relay LED 2 (red)	Relay LED 3 (red)	Relay LED 4 (red)	the receiver will be activated when...
●	○	○	○	Load A is selected on the transmitter
○	●	○	○	Load B is selected on the transmitter
○	○	●	○	Load C is selected on the transmitter
○	○	○	●	Load D is selected on the transmitter
○	○	○	○	The receiver does not listen to any load(s) and will always be activated when receiving a radio package.

NOTE: If no button is pressed within approximately 10 seconds, the receiver will automatically return to normal operation.

9.6.2 CHANGE LOAD SELECT

1. Press the **Select** button once.
Relay LED 1 flashes. Load A can be activated.
2. Press the **Function** button to enable/ unable the Load setting.
Function LEDs 3 (green) and 4 (orange) light when a Load has been activated. They are off when no Load has been selected.
3. Press the **Select** button once to move to the next available **Load** (repeat until the LED combination corresponds to the desired **Load select**).
The corresponding status LED flashes and the Load can be activated.
4. Press the **Select** button to confirm.
The new configuration is saved.

The receiver returns to normal operation.

9.7 Register a batteryless button (BLB) transmitter

This procedure is intended for customer specific applications where a transmitter's function buttons 1–4 can be remapped (duplicated) to other buttons on the same transmitter or on a BLB transmitter.



RISK OF UNINTENDED EQUIPMENT OPERATION

Only transmitters that are intended for use should be registered in the receiver.

Failure to follow these instructions could result in death, serious injury, or equipment damage.



RISK OF UNINTENDED EQUIPMENT OPERATION

Do not perform this action when the receiver is in a session with another transmitter. The radio communication may be interrupted or broken.

Failure to follow these instructions could result in death, serious injury, or equipment damage.

IMPORTANT! For this procedure to succeed, the receiver must be set to discontinuous mode, the zero position check must be disabled and the receiver must be locked to channel 11.

NOTE: To establish a radio link between the transmitter and the receiver, both units must be set to the same radio mode.

1. Press the **Function** button.
Function LED 1 lights (red).
2. Press the **Select** button.
All relay LEDs light (red).
3. Press the **Function** button.
Relay LED 1 flashes (red).
Button remapping is now possible with the following settings as default¹:
LED 1 = button 1, LED 2 = button 2, LED 3 = button 3 and LED 4 = button 4
4. Press the **Function** button to move between the available "button remaps 1–4" until the desired button remap is selected.

¹For other settings, contact your representative for assistance.

The corresponding relay LED flashes.

5. Press the **Select** button to confirm.

The corresponding relay LED stops flashing and remains lit. The receiver is in BLB registration mode.

NOTE: If no BLB button is pressed within 10 seconds, the receiver will exit registration mode.

6. Press the BLB button to be remapped to.

All function LEDs and the selected relay LED flash 3 times. The button has been remapped.

The receiver returns to normal operation.

9.8 Log a transmitter out

NOTE: Only for **continuous** radio mode.

NOTE: The login/logout function cannot be activated/deactivated in the receiver. Contact your representative for assistance.

For this receiver, the login/logout function is activated by default.

NOTE: This logout option should be used when a lost or damaged transmitter must be logged out from the receiver.

NOTE: If a transmitter has been lost or seriously damaged, use the replace procedure on the transmitter whenever possible.

Function LED 1 (red) is lit to indicate that one or more transmitter(s) are registered in the receiver and that one transmitter is logged in.



RISK OF UNINTENDED EQUIPMENT OPERATION

Ensure that the stop relays are deactivated before proceeding with the following instructions; LED SR 1–2 must be Off.

Failure to follow these instructions could result in death, serious injury, or equipment damage.

NOTE: Logout can only be performed when the transmitter is on and a radio link with one or more receivers has been established. The receiver must be powered-up for the logout procedure to be successful.

1. Press and hold the **Select** button for approx. 4 seconds or until function LED 4 goes off.
2. Release the **Select** button.
All function LEDs light briefly.

The logged in transmitter has been logged out. The receiver returns to normal operation. Any registered transmitter can now log in.

9.9 Erase all registered transmitters

NOTE: The following instructions will erase all registered transmitters from the receiver.

NOTE: An erased transmitter cannot be logged in to the receiver until it has been registered in the receiver again.

1. Press the **Function** button once.
Function LED 1 lights (red).
2. Press and hold the **Select** button for approx. 4 s or until all relay LEDs go off.
All registered transmitters have been erased.

The receiver returns to normal operation.

9.10 Master reset of the receiver

This procedure will erase all settings from the receiver and restore factory defaults.

NOTE: The erase function cannot be activated/deactivated in the receiver. Contact your representative for assistance.



RISK OF UNINTENDED EQUIPMENT OPERATION

Do not perform this action when the receiver is in a session with another transmitter. The radio communication may be interrupted or broken.

Failure to follow these instructions could result in death, serious injury, or equipment damage.

1. Press both the **Select** and the **Function** buttons for approx. 10 seconds or until all function LEDs go off.
2. Release both buttons.
All function LEDs light briefly. The receiver has been reset.

The receiver returns to normal operation.

CHAPTER 10: WARRANTY, SERVICE, REPAIRS, AND MAINTENANCE

Tele Radio products are covered by a warranty against material, construction and manufacturing faults. During the warranty period, Tele Radio may replace the product or faulty parts. Work under warranty must be performed by Tele Radio or by an authorized service center specified by Tele Radio.

The following are **not** covered by the warranty:

- Faults resulting from normal wear and tear
- Parts of a consumable nature
- Products that have been subject to unauthorized modifications
- Faults resulting from incorrect installation and use
- Damp and water damage

Maintenance

- Repairs and maintenance must be performed by qualified personnel
- Only use spare parts from Tele Radio
- Contact your representative for service or any other assistance
- Keep the product in a clean, dry place
- Keep contacts and antennas clean
- Wipe off dust using a slightly damp, clean cloth

NOTE: Never use cleaning solutions or high-pressure washer.

CHAPTER 11: REGULATORY INFORMATION

11.1 Europe

Applies to: **R23-01, R23-03; R23-02, R23-04**

11.1.1 CE MARKING



Hereby, Tele-Radio i Lysekil AB, declares that the product(s) listed above is/are in compliance with the Radio Equipment Directive 2014/53/EU. The latest version of the complete EU Declaration of Conformity is available at the following website: www.tele-radio.com.

11.1.2 WEEE DIRECTIVE



This symbol means that inoperative electrical and electronic products must not be mixed with household waste. The European Union has implemented a collection and recycling system for which producers are responsible. For proper treatment, recovery and recycling, please take this product to a designated collection point.

Tele Radio strives to minimize the use of hazardous materials, promotes reuse and recycling, and reduces emissions to air, soil and water. When a commercially viable alternative is available, Tele Radio strives to restrict or eliminate substances and materials that pose an environmental, health or safety risk.

11.2 United Kingdom

Applies to: **R23-01, R23-03; R23-02, R23-04**

11.2.1 UKCA MARKING



UK Importer: Tele Radio (UK) LTD
1 SEYMOUR COURT,
MANOR PARK, RUNCORN, WA7 1SY, UK
Email: sales@teleradiouk.com

The latest version of the complete UKCA Declaration of Conformity is available on request. Contact your representative for more information.

11.3 North America

Applies to: **R23-01, R23-03; R23-02, R23-04**

11.3.1 FCC STATEMENT

This device complies with part 15 of the FCC Rules. Operation is subject to the following two conditions:

- (1) This device may not cause harmful interference, and
- (2) this device must accept any interference received, including interference that may cause undesired operation.

Changes or modifications not expressly approved by the party responsible for compliance could void the user's authority to operate the equipment.

This equipment has been tested and found to comply with the limits for a Class B digital device, pursuant to part 15 of the FCC Rules. These limits are designed to provide reasonable protection against harmful interference in a residential installation. This equipment generates uses and can radiate radio frequency energy and, if not installed and used in accordance with the instructions, may cause harmful interference to radio communications. However there is no guarantee that interference will not occur in a particular installation. If this equipment does cause harmful interference to radio or television reception, which can be determined by turning the equipment off and on, the user is encouraged to try to correct the interference by one or more of the following measures:

- Reorient or relocate the receiving antenna.
- Increase the separation between the equipment and receiver.
- Connect the equipment into an outlet on a circuit different from that to which the receiver is connected.
- Consult the dealer or an experienced radio/TV technician for help.

To satisfy FCC RF exposure requirements, a separation distance of 20 cm or more should be maintained between the antenna of this device and persons during device operation. To ensure compliance, operations at closer than this distance is not recommended.

11.3.2 IC STATEMENT

This product complies with Industry Canada's licence-exempt RSSs. Operation is subject to the following two conditions:

- (1) This device may not cause interference; and

(2) This device must accept any interference, including interference that may cause undesired operation of device.

Le présent appareil est conforme aux CNR d'Industrie Canada applicables aux appareils radio exempts de licence. L'exploitation est autorisée aux deux conditions suivantes :

- 1) l'appareil ne doit pas produire de brouillage;
- 2) l'appareil doit accepter tout brouillage radioélectrique subi, même si le brouillage est susceptible d'en compromettre le fonctionnement.

This radio transmitter has been approved by Industry Canada to operate with the antenna types listed below with the maximum permissible gain and required antenna impedance for each antenna type indicated. Antenna types not included in this list, having a gain greater than the maximum gain indicated for that type, are strictly prohibited for use with this device.

Gain of antenna: 3.0 dBi max.

Type of antenna: 50 ohm, Omni-directional

Le présent émetteur radio a été approuvé par Industrie Canada pour fonctionner avec les types d'antenne énumérés ci-dessous ayant le gain admissible maximal et l'impédance requise pour chaque type d'antenne indiqué. Les types d'antenne non inclus dans cette liste, ou dont le gain est supérieur au gain maximal indiqué, sont strictement interdits pour l'exploitation de l'émetteur.

Gain d'antenne: 3.0 dBi maximum

Type d'antenne: 50 ohm, omnidirectionnel

To satisfy IC RF exposure requirements, a separation distance of 20 cm or more should be maintained between the antenna of this device and persons during device operation. To ensure compliance, operation at closer than this distance is not recommended.

Afin d'assurer la conformité aux exigences de la IC en matière d'exposition aux RF, une distance de séparation d'au moins 20 cm doit être maintenue entre l'antenne de cet appareil et toute personne à proximité pendant le fonctionnement de l'appareil. Pour assurer le respect de ces exigences, il n'est pas recommandé d'utiliser l'appareil à une distance inférieure à celle-ci.

11.3.3 FCC/IC LABELS

The radio module in this product is labeled with its own FCC ID and IC numbers. The FCC ID and IC numbers are not visible when the radio module is installed inside

another device. Therefore, the outside of the device into which the module is installed must also display a label referring to the enclosed radio module. The final end device must be labeled in a visible area with the following:

“Contains FCC ID: ONFC1902A

“Contains IC: 4807A-C1902A

The FCC and IC numbers are found on the product label.

ANNEX A: CANopen SPECIFICATION FOR R23 (IN ENGLISH)

For receivers using Software version **SW0028-09v09** or higher.

A.1 Introduction	75
A.2 General	75
A.3 Bus termination	76
A.4 Selection of CANopen node ID	76
A.5 Selection of CANopen baud rate	76
A.6 Configuration of CANopen object dictionary	77
A.7 LED indications	77
A.8 Internal states	78
A.9 Pre-defined connection set	79
A.10 Transmit Process Data Objects (TPDO) overview	80
A.11 Receive Process Data Objects (RPDO) overview	81
A.12 Manufacturer Specific Objects	82
A.13 Emergency Object (EMCY)	88
A.14 Object Dictionary	89

Version: v01

A.1 Introduction

This document describes the CANopen specification for Panther systems and applies to both Panther R18 and R23 receivers.

A.2 General

The Panther receiver CANopen interface operates according to CANopen Application Layer and Communication Profile and Pre-Defined Connection Set defined in CiA DS-301 version 4.2.0.

General features:

- CANopen Slave device
- 4 freely mappable Transmit Process Data Objects (TPDO)
- 4 freely mappable Receive Process Data Objects (RPDO)

- 1 Service Data Object (SDO)
- Synchronisation Object (SYNC) Consumer
- Emergency Object (EMCY) Producer
- NMT protocols
- Bootup Protocol
- Node Guarding Protocol
- Heartbeat Protocol
- Layer Setting Service (LSS)
- CANopen Node ID selectable via Settings Manager or LSS: 1-127
- CANopen baud rate selectable via Settings Manager or LSS: 10 kbps, 20 kbps, 50 kbps, 100 kbps, 125 kbps, 250 kbps, 500 kbps, 800 kbps, 1 Mbps
- Vendor ID: 0x000000A6

Limitations

EMCY message is not transmitted and CAN-error LED is inactive when a missing heartbeat (as consumer) / guard message (as slave) is configured but not detected or when a received PDO is smaller than expected.

A.3 Bus termination

The CANopen interface contains an internal bus termination resistor. If the Panther receiver is the last unit on the bus, the bus has to be terminated, which can be done by activating the internal termination using the PC program Settings Manager, or by connecting an external termination resistor.

A.4 Selection of CANopen node ID

The CANopen node ID is selected using Tele Radio's proprietary configuration software – Settings Manager–. The selected node ID has to be in the range 1 to 127.

A.5 Selection of CANopen baud rate

The CANopen baud rate is selected using Tele Radio's proprietary configuration software – Settings Manager–. The following baud rates can be selected: 10 kbps, 20 kbps, 50 kbps, 100 kbps, 125 kbps, 250 kbps, 500 kbps, 800 kbps, 1 Mbps.

A.6 Configuration of CANopen object dictionary

A custom CANopen mapping can be configured using the PC program Settings Manager. This is above the CANopen protocol and changes what values are available to map in TPDOs and RPDOs. Changing this mapping is outside the scope of this document.

A.7 LED indications

The CANopen interface has two indication LEDs, see table below.

A.7.1 RUN-LED

LED State	Indication	Description
Off	-	No power or CAN interface deactivated
Green	OPERATIONAL	State=OPERATIONAL
Green, blinking	PRE-OPERATIONAL	State=PRE-OPERATIONAL
Green, single flash	STOPPED	State=STOPPED

A.7.2 ERROR-LED

LED State	Indication	Description
Off	-	No power or CAN interface deactivated
Red, single flash	Warning limit reached	A bus error counter reached or exceeded its warning level.
Red, flickering	LSS	LSS services in progress
Red	Bus off (Fatal Event)	Bus off.

A.8 Internal states

The CANopen interface supports the following states:

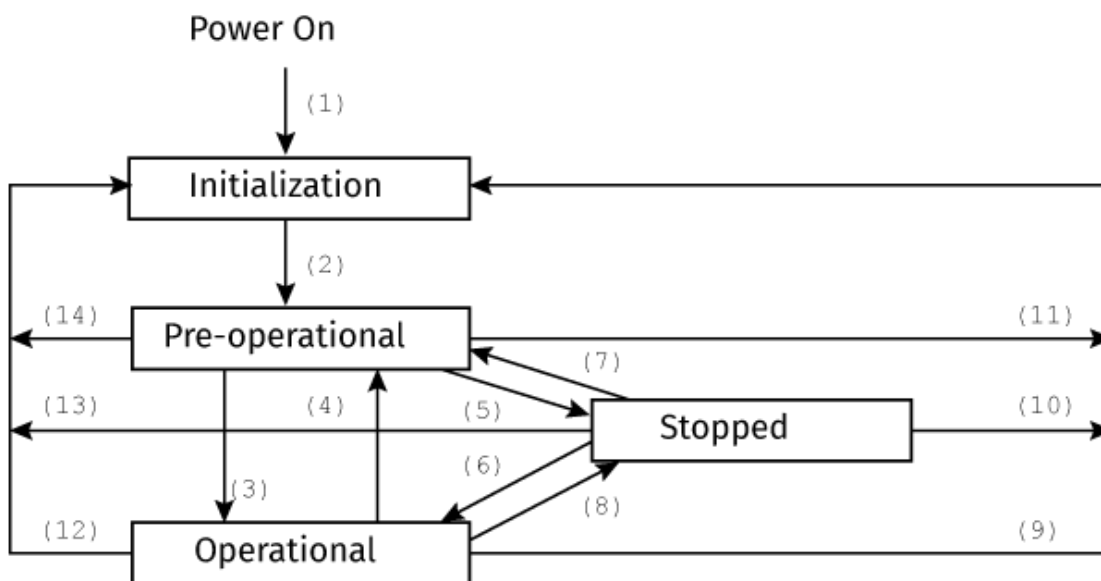

State Transition	Trigger for State Transition
(1)	At Power On the Initialization state is entered autonomously
(2)	Initialization finished – enter state PRE-OPERATIONAL automatically
(3), (6)	Start Remote Node indication (NMT message)
(4), (7)	Enter PRE-OPERATIONAL State indication (NMT message)
(5), (8)	Stop Remote Node indication (NMT message)
(9), (10), (11)	Reset Node indication (NMT message)
(12), (13), (14)	Reset Communication indication (NMT message)

A.9 Pre-defined connection set

The communication objects according to the pre-defined connection set have the following COB-IDs and communication parameters:

Object	Default COB-ID	Communication/Mapping Parameters at Index
NMT	0h	-
SYNC	80h	1005h, 1006h, 1007h, 1019h
EMERGENCY (EMCY)	80h + Node ID	1014h, 1015h
RPDO 1	200h + Node ID	1400h, 1600h
RPDO 2	300h + Node ID	1401h, 1601h
RPDO 3	400h + Node ID	1402h, 1602h
RPDO 4	500h + Node ID	1403h, 1603h
TPDO 1	180h + Node ID	1800h, 1A00h
TPDO 2	280h + Node ID	1801h, 1A01h
TPDO 3	380h + Node ID	1802h, 1A02h
TPDO 4	480h + Node ID	1803h, 1A03h
Default SDO Client->Server (rx)	600h + Node ID	1200h
Default SDO Server->Client (tx)	580h + Node ID	1200h
NMT Error Control	700h + Node ID	1016h, 1017h

Default PDO transmission type is 254 (transmission when data changes).

A.10 Transmit Process Data Objects (TPDO) overview

The default mappings of the TPDOs are listed below. These are sent from the Panther Gen2 receiver to the CANopen network. The index/sub-index in the object dictionary is shown below each description.

TPDO 1: System status

UNSIGNED8	UNSIGNED8	UNSIGNED8	UNSIGNED8	UNSIGNED16		UNSIGNED16	
Byte 1	Byte 2	Byte 3	Byte 4	Byte 5	Byte 6	Byte 7	Byte 8
RX packet counter	Radio link quality	Radio link channel	Main TX type	Main TX radio link flags		Main TX load select	
2100h/01h	2100h/02h	2100h/03h	2100h/04h	2101h/03h		2101h/04h	

TPDO 2: Buttons and directions

UNSIGNED16		UNSIGNED16		UNSIGNED16		UNSIGNED16	
Byte 1	Byte 2	Byte 3	Byte 4	Byte 5	Byte 6	Byte 7	Byte 8
Main TX buttons, step 1		Main TX buttons, step 2		Main TX buttons, both steps		Directions	
2101h/05h		2101h/06h		2101h/07h		2101h/08h	

TPDO 3: Reserved

N/A	N/A	N/A	N/A	N/A	N/A	N/A	N/A
Byte 1	Byte 2	Byte 3	Byte 4	Byte 5	Byte 6	Byte 7	Byte 8
Reserved	Reserved	Reserved	Reserved	Reserved	Reserved	Reserved	Reserved
Not mapped				Not mapped			

TPDO 4: TX id

UNSIGNED32				N/A			
Byte 1	Byte 2	Byte 3	Byte 4	Byte 5	Byte 6	Byte 7	Byte 8
Main TX id				Reserved	Reserved	Reserved	Reserved
2102h/07h				Not mapped			

A.11 Receive Process Data Objects (RPDO) overview

The default mappings of the RPDOs are listed below. These are received by the Panther receiver from the CANopen network. The index/sub-index in the object dictionary is shown below each description.

RPDO 1: Fieldbus input register 1 and 2

UNSIGNED32				UNSIGNED32			
Byte 1	Byte 2	Byte 3	Byte 4	Byte 5	Byte 6	Byte 7	Byte 8
Generic U32 RPDO object 1				Reserved			
2200h/01h				Not mapped			

RPDO 2: Fieldbus input register 3 and 4

UNSIGNED32				UNSIGNED32			
Byte 1	Byte 2	Byte 3	Byte 4	Byte 5	Byte 6	Byte 7	Byte 8
Reserved				Reserved			
Not mapped				Not mapped			

RPDO 3: Fieldbus input register 5 and 6

UNSIGNED32				UNSIGNED32			
Byte 1	Byte 2	Byte 3	Byte 4	Byte 5	Byte 6	Byte 7	Byte 8
Reserved				Reserved			
Not mapped				Not mapped			

RPDO 4: Fieldbus input register 7 and 8

UNSIGNED32				UNSIGNED32			
Byte 1	Byte 2	Byte 3	Byte 4	Byte 5	Byte 6	Byte 7	Byte 8
Reserved				Reserved			
Not mapped				Not mapped			

A.12 Manufacturer Specific Objects

The following Manufacturer Specific Objects are available in the object dictionary:

Index	Object Name	Description	Data Type	Access
2000h	Generic U8 RPDO objects	32 UNSIGNED8 input data objects accessible with value selectors	U8 Array	RWW
2001h	Generic U16 RPDO objects	16 UNSIGNED16 input data objects accessible with value selectors	U16 Array	RWW
2002h	Generic U32 RPDO objects	8 UNSIGNED32 input data objects accessible with value selectors	U32 Array	RWW
2003h	Generic I8 RPDO objects	32 INTEGER8 input data objects accessible with value selectors	I8 Array	RWW
2004h	Generic I16 RPDO objects	16 INTEGER16 input data objects accessible with value selectors	I16 Array	RWW
2005h	Generic I32 RPDO objects	8 INTEGER32 input data objects accessible with value selectors	I32 Array	RWW
2100h	Generic U8 TPDO objects	32 UNSIGNED8 output data objects configurable with value selectors	U8 Array	RO
2101h	Generic U16 TPDO objects	16 UNSIGNED16 output data objects configurable with value selectors	U16 Array	RO
2102h	Generic U32 TPDO objects	8 UNSIGNED32 output data objects configurable with value selectors	U32 Array	RO
2103h	Generic I8 TPDO objects	32 INTEGER8 output data objects configurable with value selectors	I8 Array	RO
2104h	Generic I16 TPDO objects	16 INTEGER16 output data objects configurable with value selectors	I16 Array	RO
2105h	Generic I32 TPDO objects	8 INTEGER32 output data objects configurable with value selectors	I32 Array	RO
2200h	System commands		U32 Array	RWW

A.12.1 OBJECT 2000H: GENERIC U8 RPDO OBJECTS

Index: 2000h Name: Generic U8 RPDO objects Sub-indexes: 20h Data type: UNSIGNED8 Access: RWW		
Sub-index	Description	Value selector (internal parameter)
1-32	General feedback from CANopen network (not used in default mapping)	Group: CANOPEN_INPUT_8BIT (50) Type: UINT8 (1) Indexes: 0-31

A.12.2 OBJECT 2001H: GENERIC U16 RPDO OBJECTS

Index: 2001h Name: Generic U16 RPDO objects Sub-indexes: 10h Data type: UNSIGNED16 Access: RWW		
Sub-index	Description	Value selector (internal parameter)
1-16	General feedback from CANopen network (not used in default mapping)	Group: CANOPEN_INPUT_16BIT (51) Type: UINT16 (3) Indexes: 0-15

A.12.3 OBJECT 2002H: GENERIC U32 RPDO OBJECTS

Index: 2002h Name: Generic U32 RPDO objects Sub-indexes: 08h Data type: UNSIGNED32 Access: RWW		
Sub-index	Description	Value selector (internal parameter)
1-8	General feedback from CANopen network (two sub-indexes mapped to each RPDO)	Group: CANOPEN_INPUT_32BIT (52) Type: UINT32 (5) Indexes: 0-7

A.12.4 OBJECT 2003H: GENERIC I8 RPDO OBJECTS

Index: 2003h Name: Generic I8 RPDO objects Sub-indexes: 20h Data type: INTEGER8 Access: RWW		
Sub-index	Description	Value selector (internal parameter)
1-32	General feedback from CANopen network (not used in default mapping)	Group: CANOPEN_INPUT_8BIT (50) Type: INT8 (2) Indexes: 0-31

A.12.5 OBJECT 2004H: GENERIC I16 RPDO OBJECTS

Index: 2004h Name: Generic I16 RPDO objects Sub-indexes: 10h Data type: INTEGER16 Access: RWW		
Sub-index	Description	Value selector (internal parameter)
1-16	General feedback from CANopen network (not used in default mapping)	Group: CANOPEN_INPUT_16BIT (51) Type: INT16 (4) Indexes: 0-15

A.12.6 OBJECT 2005H: GENERIC I32 RPDO OBJECTS

Index: 2005h Name: Generic I32 RPDO objects Sub-indexes: 08h Data type: INTEGER32 Access: RWW		
Sub-index	Description	Value selector (internal parameter)
1-8	General feedback from CANopen network (not used in default mapping)	Group: CANOPEN_INPUT_32BIT (52) Type: INT32 (6) Indexes: 0-7

A.12.7 OBJECT 2100H: GENERIC U8 TPDO OBJECTS

Index: 2100h Name: Generic U8 TPDO objects Sub-indexes: 20h Data type: UNSIGNED8 Access: RO		
Sub-index	Description	Value selector (internal parameter)
1	RX packet counter Incremented by one on every 16 received valid radio packets	Group: SESSION_DATA (4) Type: UINT8 (1) Index: 4
2	Radio link quality Based on RSSI, range 0...15 Corresponds to RSSI values -90...-60	Group: SESSION_DATA (4) Type: UINT8 (1) Index: 5
3	Radio link channel Zero if no session active, otherwise range 11...26	Group: SESSION_DATA (4) Type: UINT8 (1) Index: 6
4	Main TX type Value 00h => No TX active/Invalid Value 01h => Gen1 TX Value 81h => Gen1 PLD TX	Group: TX2RX_STATE_DATA (1) Type: UINT8 (1) Index: 36
5-32	Not used in default mapping	-

A.12.8 OBJECT 2101H: GENERIC U16 TPDO OBJECTS

Index: 2101h Name: Generic U16 TPDO objects Sub-indexes: 10h Data type: UNSIGNED16 Access: RO		
Sub-index	Description	Value selector (internal parameter)
1-2	Not used in default mapping	-

3	Main TX radio link flags Bit 00: RAW_LINK Bit 01: ACTIVE_LINK Bit 02: SESSION Bit 03: SHORT_LINK Bit 04: ZERO_LINK Bit 05: START_PHASE Bit 06: KILL_PHASE Bit 07: ACTIVE_STOP Bit 08: PASSIVE_STOP Bit 09: CM_ACT_LINK Bit 10: BAD_BATTERY Bit 11: LOGOUT Bit 12-15: Reserved	Group: TX2RX_STATE_DATA (1) Type: UINT16 (3) Index: 5
4	Main TX load select Bit 00: Load A Bit 01: Load B Bit 02: Load C Bit 03: Load D Bit 04-15: Reserved	Group: TX2RX_STATE_DATA (1) Type: UINT16 (3) Index: 6
5	Main TX buttons, step 1 Bit 00: Button 01, step 1 Bit 01: Button 02, step 1 Bit 02: Button 03, step 1 Bit 03: Button 04, step 1 Bit 04: Button 05, step 1 Bit 05: Button 06, step 1 Bit 06: Button 07, step 1 Bit 07: Button 08, step 1 Bit 08: Button 09, step 1 Bit 09: Button 10, step 1 Bit 10: Button 11, step 1 Bit 11: Button 12, step 1 Bit 12: Button 13, step 1 Bit 13: Button 14, step 1 Bit 14: Button 15, step 1 Bit 15: Button 16, step 1	Group: TX2RX_STATE_DATA (1) Type: UINT16 (3) Index: 2
6	Main TX buttons, step 2 Bit 00: Button 01, step 2 Bit 01: Button 02, step 2 Bit 02: Button 03, step 2 Bit 03: Button 04, step 2 Bit 04: Button 05, step 2 Bit 05: Button 06, step 2 Bit 06: Button 07, step 2 Bit 07: Button 08, step 2 Bit 08: Button 09, step 2 Bit 09: Button 10, step 2 Bit 10: Button 11, step 2 Bit 11: Button 12, step 2 Bit 12: Button 13, step 2 Bit 13: Button 14, step 2 Bit 14: Button 15, step 2 Bit 15: Button 16, step 2	Group: TX2RX_STATE_DATA (1) Type: UINT16 (3) Index: 3

7	Main TX buttons, both steps Bit 00: Button 01, both steps Bit 01: Button 02, both steps Bit 02: Button 03, both steps Bit 03: Button 04, both steps Bit 04: Button 05, both steps Bit 05: Button 06, both steps Bit 06: Button 07, both steps Bit 07: Button 08, both steps Bit 08: Button 09, both steps Bit 09: Button 10, both steps Bit 10: Button 11, both steps Bit 11: Button 12, both steps Bit 12: Button 13, both steps Bit 13: Button 14, both steps Bit 14: Button 15, both steps Bit 15: Button 16, both steps	Group: TX2RX_STATE_DATA (1) Type: UINT16 (3) Index: 4
8	Directions Bit 00: Direction 01, pos negative 01 Bit 01: Direction 01, pos negative 02 Bit 02: Direction 01, pos positive 01 Bit 03: Direction 01, pos positive 02 Bit 04: Direction 02, pos negative 01 Bit 05: Direction 02, pos negative 02 Bit 06: Direction 02, pos positive 01 Bit 07: Direction 02, pos positive 02 Bit 08: Direction 03, pos negative 01 Bit 09: Direction 03, pos negative 02 Bit 10: Direction 03, pos positive 01 Bit 11: Direction 03, pos positive 02	Group: Information about current session (4) Type: UINT16 (3) Index: 6

A.12.9 OBJECT 2102H: GENERIC U32 TPDO OBJECTS

Index: 2102h Name: Generic U32 TPDO objects Sub-indexes: 08h Data type: UNSIGNED32 Access: RO		
Sub-index	Description	Value selector (internal parameter)
1-4	Not used in default mapping	-
5-6	Not used in default mapping	-
7	Main TX id Zero if no session with main TX, id of main TX otherwise	Group: TX2RX_STATE_DATA (1) Type: UINT32 (5) Index: 0

A.12.10 OBJECT 2103H: GENERIC I8 TPDO OBJECTS

Index: 2103h Name: Generic I8 TPDO objects Sub-indexes: 20h Data type: INTEGER8 Access: RO		
Sub-index	Description	Value selector (internal parameter)
1-24	Not used in default mapping	-

A.12.11 OBJECT 2104H: GENERIC I16 TPDO OBJECTS

Index: 2104h Name: Generic I16 TPDO objects Sub-indexes: 10h Data type: INTEGER16 Access: RO		
Sub-index	Description	Value selector (internal parameter)
1-16	Not used in default mapping	-

A.12.12 OBJECT 2105H: GENERIC I32 TPDO OBJECTS

Index: 2105h		
Name: Generic I32 TPDO objects		
Sub-indexes: 08h		
Data type: INTEGER32		
Access: RO		
Sub-index	Description	Value selector (internal parameter)
1-8	Not used in default mapping	-

A.12.13 OBJECT 2200H: SYSTEM COMMANDS

Index: 2200h	
Name: System commands	
Sub-indexes: 01h	
Data type: UNSIGNED32	
Access: RWW	
Sub-index	Description
1	<p>System command</p> <p>Bit 00-07: Contains the ascii value 'T'</p> <p>Bit 08-15: Contains the ascii value 'R'</p> <p>Bit 16-23: Contains the ascii value 'C'</p> <p>Bit 24-31: One of the following values:</p> <p>01h: Activate TX register mode on RX</p>

A.13 Emergency Object (EMCY)

The Emergency Object is sent to the CANopen network with the following information:

Byte 0	Byte 1	Byte 2	Byte 3	Byte 4	Byte 5	Byte 6	Byte 7
EMCY Error Code Low Byte	EMCY Error Code High Byte	Error Register (1001h)	Manufacturer specific field (not used)				

The EMCY Error Codes for internal CANopen diagnostics are interpreted as follows:

EMCY Error Code	Description
8100h	Communication error
8110h	CAN controller signalled a lost message (overrun)
8120h	CAN controller reached the warning limit due to error frames
8130h	An error control event has occurred (either a life guarding or a heartbeat event)
8140h	CAN controller has recovered from a BUS OFF state
8210h	A received PDO was smaller than specified by the valid mapping table
8220h	The DLC of a received PDO exceeded the length specified by the valid mapping table

NOTE: EMCY message is not transmitted when a missing heartbeat (as consumer) / guard message (as slave) is configured but not detected or when a received PDO is smaller than expected.

A.14 Object Dictionary

A.14.1 ABBREVIATIONS

RO	Read Only
RW	Read, Write
RWW	Read, Write on process output
U8	Unsigned8
U16	Unsigned16
U32	Unsigned32
I8	Integer8
I16	Integer16
I32	Integer32

A.14.2 GENERAL PARAMETERS

Index	Object Name	Sub-Index	Description	Data Type	Access	Note
0002h	Dummy Object	00h	Dummy Type Object for I8	U32	RW	0000 0008h
0003h	Dummy Object	00h	Dummy Type Object for I16	U32	RW	0000 0010h
0004h	Dummy Object	00h	Dummy Type Object for I32	U32	RW	0000 0020h
0005h	Dummy Object	00h	Dummy Type Object for U8	U32	RW	0000 0008h
0006h	Dummy Object	00h	Dummy Type Object for U16	U32	RW	0000 0010h
0007h	Dummy Object	00h	Dummy Type Object for U32	U32	RW	0000 0020h
1000h	Device Type	00h	Device Type	U32	RO	0000 0000h (No Profile)
1001h	Error Register	00h	Error Register	U8	RO	-
1003h	Pre-defined error field	00h	Number of errors	U8	RW	
		01h-0Ah	Error field	U32	RO	
1005h	COB-ID Sync	00h	COB-ID Sync	U32	RW	Default value is 0000 0080h
1006h	Communication Cycle Period	00h	Period between transmissions of SYNC in μ s	U32	RW	0000 0000h
1007h	Synchronous Window Length	00h	Synchronous Window Length in μ s (0 is disabled)	U32	RW	0000 0000h
1008h	Manufacturer Device Name	00h	Manufacturer Device Name	Visible string	RO	"PN-R23"
1009h	Manufacturer Hardware Version	00h	Manufacturer Hardware Version	Visible string	RO	-
100Ah	Manufacturer Software Version	00h	Manufacturer Software Version	Visible string	RO	"SW0028-09vXX" CAN
100Ch	Guard Time	00h	Guard Time	U16	RW	-
100Dh	Life Time Factor	00h	Life Time Factor	U8	RW	-
1010h	Store Parameters	00h	Largest sub-index supported	U8	RO	02h
		01h	Store all parameters	U32	RW	Both sub-indexes have the same effect when ASCII "SAVE" is written
		02h	Store Communication parameters	U32	RW	

Index	Object Name	Sub-Index	Description	Data Type	Access	Note
1011h	Restore Parameters	00h	Largest sub-index supported	U8	RO	02h
		01h	Restore all default parameters	U32	RW	Both sub-indexes have the same effect when ASCII "LOAD" is written
		02h	Restore communication default parameters	U32	RW	
1014h	COB-ID EMCY	00h	COB-ID EMCY	U32	RO	-
1015h	Inhibit Time EMCY	00h	Inhibit Time EMCY	U16	RW	Default value is 0000h
1016h	Consumer Heartbeat Time	00h	Number of entries	U8	RO	01h
		01h	Consumer Heartbeat Time	U32	RW	Node ID + Heartbeat Time. Value must be a multiple of 1ms.
1017h	Producer Heartbeat Time	00h	Producer Heartbeat Time	U16	RW	-
1018h	Identity object	00h	Number of entries	U8	RO	04h
		01h	Vendor ID	U32	RO	0000 00A6h
		02h	Product Code	U32	RO	0x17 (23)
		03h	Revision Number	U32	RO	-
		04h	Serial Number	U32	RO	id number of the unit
1019h	Sync counter	00h	Sync counter	U8	RO	-

A.14.3 SERVER SDO PARAMETERS

Index	Object Name	Sub-Index	Description	Data Type	Access	Note
1200h	Server SDO Parameter	00h	Largest sub-index supported	U8	RO	02h
		01h	COB ID Client to Server (Receive SDO)	U32	RO	Node ID + 0600h
		02h	COB ID Server to Client (Transmit SDO)	U32	RO	Node ID + 0580h

A.14.4 RECEIVE PDO COMMUNICATION PARAMETERS

Index	Object Name	Sub-Index	Description	Data Type	Access	Note
1400h ... 1403h	Receive PDO Communication Parameter	00h	Largest sub-index supported	U8	RO	05h
		01h	COB-ID used by PDO	U32	RW	-
		02h	Transmission Type	U8	RW	-
		03h	Inhibit Time (not used)	U16	RW	-
		05h	Event Timer (not used)	U16	RW	-

A.14.5 RECEIVE PDO MAPPING PARAMETERS

Index	Object Name	Sub-Index	Description	Data Type	Access	Note
1600h ... 1603h	Receive PDO Mapping Parameter	00h	Number of mapped application objects in PDO	U8	RW	-
		01h	Mapped object No.1	U32	RW	-
		02h	Mapped object No.2	U32	RW	-
		U32	RW	-
		n	Mapped object No.n	U32	RW	-

A.14.6 TRANSMIT PDO COMMUNICATION PARAMETERS

Index	Object Name	Sub-Index	Description	Data Type	Access	Note
1800h ... 1803h	Transmit PDO Communication Parameter	00h	Largest sub-index supported	U8	RO	05h
		01h	COB-ID used by PDO	U32	RW	-
		02h	Transmission Type	U8	RW	-
		03h	Inhibit Time	U16	RW	-
		05h	Event Timer (ms)	U16	RW	-

A.14.7 TRANSMIT PDO MAPPING PARAMETERS

Index	Object Name	Sub-Index	Description	Data Type	Access	Note
1A00h ... 1A03h	Transmit PDO Mapping Parameter	00h	Number of mapped application objects in PDO	U8	RW	-
		01h	Mapped object No.1	U32	RW	-
		02h	Mapped object No.2	U32	RW	-
		U32	RW	-
		n	Mapped object No.n	U32	RW	-

A.14.8 MANUFACTURER SPECIFIC PARAMETERS

Index	Object Name	Sub-Index	Description	Data Type	Access	Note
2000h	Generic U8 RPDO objects	00h	Largest sub-index supported	U8	RO	20h
		01h-20h	32 UNSIGNED8 input data objects accessible with value selectors in the Panther RX using the PC program Settings Manager	U8	RWW	
2001h	Generic U16 RPDO objects	00h	Largest sub-index supported	U8	RO	10h
		01h-10h	16 UNSIGNED16 input data objects accessible with value selectors in the Panther RX using the PC program Settings Manager	U16	RWW	
2002h	Generic U32 RPDO objects	00h	Largest sub-index supported	U8	RO	08h
		01h-08h	8 UNSIGNED32 input data objects accessible with value selectors in the Panther RX using the PC program Settings Manager	U32	RWW	

Index	Object Name	Sub-Index	Description	Data Type	Access	Note
2003h	Generic I8 RPDO objects	00h	Largest sub-index supported	U8	RO	20h
		01h-20h	32 INTEGER8 input data objects accessible with value selectors in the Panther RX using the PC program Settings Manager	I8	RWW	
2004h	Generic I16 RPDO objects	00h	Largest sub-index supported	U8	RO	10h
		01h-10h	16 INTEGER16 input data objects accessible with value selectors in the Panther RX using the PC program Settings Manager	I16	RWW	
2005h	Generic I32 RPDO objects	00h	Largest sub-index supported	U8	RO	08h
		01h-08h	8 INTEGER32 input data objects accessible with value selectors in the Panther RX using the PC program Settings Manager	I32	RWW	
2100h	Generic U8 TPDO objects	00h	Largest sub-index supported	U8	RO	20h
		01h-20h	32 UNSIGNED8 output data objects configurable with value selectors in the Panther RX using the PC program Settings Manager	U8	RO	
2101h	Generic U16 TPDO objects	00h	Largest sub-index supported	U8	RO	10h
		01h-10h	16 UNSIGNED16 output data objects configurable with value selectors in the Panther RX using the PC program Settings Manager	U16	RO	
2102h	Generic U32 TPDO objects	00h	Largest sub-index supported	U8	RO	08h
		01h-08h	8 UNSIGNED32 output data objects configurable with value selectors in the Panther RX using the PC program Settings Manager	U32	RO	
2103h	Generic I8 TPDO objects	00h	Largest sub-index supported	U8	RO	20h
		01h-20h	32 INTEGER8 output data objects configurable with value selectors in the Panther RX using the PC program Settings Manager	I8	RO	
2104h	Generic I16 TPDO objects	00h	Largest sub-index supported	U8	RO	10h
		01h-10h	16 INTEGER16 output data objects configurable with value selectors in the Panther RX using the PC program Settings Manager	I16	RO	
2105h	Generic I32 TPDO objects	00h	Largest sub-index supported	U8	RO	08h
		01h-08h	8 INTEGER32 output data objects configurable with value selectors in the Panther Gen2 RX using the PC program Settings Manager	I32	RO	
2200h	System commands	00h	Largest sub-index supported	U8	RO	01h
		01h	System command trigger	U32	RWW	

ANNEX B: J1939 SPECIFICATION FOR R23 (IN ENGLISH)

For receivers using Software version **SW0028-09v09** or higher.

B.1 Introduction	93
B.2 General	93
B.3 LED indications	95
B.4 Supported PGNs Tx (Request messages transmitted)	96
B.5 Supported PGNs Rx (Request messages accepted)	101

Version: v01

B.1 Introduction

This document describes the installation, setup and J1939 communication profile for Tele Radio receiver units **23-08** and **R23-09**. It is intended for personnel with qualifications within electrical engineering and J1939 communication. For additional documentation, see official J1939 standards.

R23-08 and R23-09 receivers have 10 standard relays on the main board that can be controlled with J1939.

B.2 General

The receiver's J1939 interface operates according to SAE J1939 DA.

This document describes the messages provided by Tele-Radio J1939 default spec and general information about using the CAN protocol with extended 29-bit CAN identifiers.

Definitions:

Parameter Group Numbers identifiers (PGN): 18-bit subset of the 29-bit extended CAN.

Suspect Parameter Numbers parameters (SPN): identifier for the CAN signals /parameters contained in the datafield.

B.2.1 GENERAL FEATURES

The receiver's J1939 unit is arbitrary address capable by default. It is possible to specify a start address in Tele Radio's proprietary configuration software – Settings

Manager– but if the address is already used, then it will automatically be changed to next available address.

- **Baud rate:** The baud rate is selected using Tele Radio's proprietary configuration software – Settings Manager–. The following baud rates can be selected: 10 kbps, 20 kbps, 50 kbps, 100 kbps, 125 kbps, 250 kbps, 500 kbps, 800 kbps, 1 Mbps.
- **Default starting network address** must be defined and set manually in Tele Radio's proprietary configuration software – Settings Manager–). Contact your representative for assistance.
Tele Radio Node claiming ends at 251/0xFB and then restarts at 0x00.
- **PGNs 0xOFF00 – 0xOFFFF** are reserved for proprietary use.
- Tele radio's default message size for J1939 is 8 bytes.

Byte \ Bit	7	6	5	4	3	2	1	0
0	7	6	5	4	3	2	1	0
1	15	14	13	12	11	10	9	8
2	23	22	21	20	19	18	17	16
3	31	30	29	28	27	26	25	24
4	39	38	37	36	35	34	33	32
5	47	46	45	44	43	42	41	40
6	55	54	53	52	51	50	49	48
7	63	62	61	60	59	58	57	56

B.2.2 LIMITATIONS

Request message (PGN:0x00EA00) is not implemented.

B.2.3 NAME MESSAGE WHEN CLAIMING ADDRESS

The Name message is 64 bit (8 bytes) and follows the structure below (for more details about addresses and names, please refer to the J1939/81 standard).

Bits 0-20 are used for the receiver's serial number.

s = serial number

	Byte 0	Byte 1	Byte 2	Byte 3	Byte 4	Byte 5	Byte 6	Byte 7
(hex) 0x	ss	ss	0s	00	00	FF	00	80

B.3 LED indications

The J1939 interface has two indication LEDs, see table below.

B.3.1 RUN-LED

LED color	On	Single flash
Green	Operational	No address

J1939 communication state	Description
Operational	Address claim is correct, processing messages.
No address	Address claim is still running or has failed.

B.3.2 ERROR-LED

LED color	On	Single flash
Red	Bus off	Warning limit reached

J1939 error code message	Problem description
Bus Off	CAN controller is in bus off.
Warning limit reached	At least one of the error counters in the CAN controller has reached or exceeded its warning level (e.g. too many error frames).

B.4 Supported PGNs Tx (Request messages transmitted)

PGNs FF80h – FF83h are 64 bits each. They are sent every 100 ms with a priority 6.

NOTE: Transmission repetition rate is set to 100ms by default but can be adjusted to customer needs. Contact your representative for assistance.

NOTE: "Priority" and "Source address" values are voluntary and can be adjusted to customer needs (contact your representative for assistance).

NOTE: In the tables below, "Priority 6" is the default values while "Source address Z/0xZZ (dec/hex)/hex" is only used as an example for the identifier.

B.4.1 PGN: SYSTEM STATUS

Transmission repetition rate	Data length (bytes)	Default priority (dec)	PGN (dec/hex)	Source address (dec/hex)	Identifier ¹ (hex)
Every 100ms	8	6	65408/ 0xFF80	Z / 0xZZ	0x18FF80ZZ

• RX packet counter

Packet counter for the number of received radio packets by the receiver unit.

SPN name	SPN start (bit)	SPN length (bit)	Description
Packet counter	0	8	Counter increases value by 1 for every 16th radio packet received and counts from 0 to 255, then resets and starts over again.

• Radio link quality

SPN name	SPN start (bit)	SPN length (bit)	Description
Radio link quality	8	8	Based on RSSI, range 0...15 Corresponds to RSSI values -90...-60

• Radio link channel

SPN name	SPN start (bit)	SPN length (bit)	Description
Radio link channel	16	8	0 = no session active 2.4 GHz frequency band: Value 11–26 => radio channel 11–26

¹Identifier (hex) = Priority (hex) + PGN (hex) + Source address (hex)

• **Main TX type**

SPN name	SPN start (bit)	SPN length (bit)	Description
Main TX type	24	8	0 =No TX active/Invalid Value 01h => Gen1 TX Value 81h => Gen1 PLD TX Value 10h => Gen2 simple TX Value 90h => Gen2 simple PLD TX Value 11h => Gen2 button TX Value 91h => Gen2 button PLD TX Value 12h => Gen2 joystick TX Value 92h => Gen2 joystick PLD TX

• **Main TX radio link flags**

SPN name	SPN start (bit)	SPN length (bit)	Description
RAW_LINK	32	1	1 =raw link active
ACTIVE_LINK	33	1	1 = active link active
SESSION	34	1	1 = session active
SHORT_LINK	35	1	1 = short link active
ZERO_LINK	36	1	1 = zero link active
START_PHASE	37	1	1 = start phase active
KILL_PHASE	38	1	1 = kill phase active
ACTIVE_STOP	39	1	1 = active stop active
PASSIVE_STOP	40	1	1 = passive stop active
CM_ACT_LINK	41	1	1 = link active
BAD_BATTERY	42	1	1 = Battery level is too low
LOGOUT	43	1	1 = logout active
Reserved	44	4	-

• **Main TX load select**

SPN name	SPN start (bit)	SPN length (bit)	Description
Load A	48	1	1 = Load A active
Load B	49	1	1 = Load B active
Load C	50	1	1 = Load C active
Load D	51	1	1 = Load B active
Reserved	52	12	-

B.4.2 PGN: BUTTONS AND DIRECTIONS

Transmission repetition rate	Data length (bytes)	Default priority (dec)	PGN (dec/hex)	Source address (dec/hex)	Identifier (Hex)
Every 100ms	8	6	65409 / 0xFF81	Z / 0xZZ	0x18FF81ZZ

• Main TX buttons, step 1

SPN name	SPN start (bit)	SPN length (bit)	Description
Button 01, step 1	0	1	1 = button active
Button 02, step 1	1	1	1 = button active
Button 03, step 1	2	1	1 = button active
Button 04, step 1	3	1	1 = button active
Button 05, step 1	4	1	1 = button active
Button 06, step 1	5	1	1 = button active
Button 07, step 1	6	1	1 = button active
Button 08, step 1	7	1	1 = button active
Button 09, step 1	8	1	1 = button active
Button 10, step 1	9	1	1 = button active
Button 11, step 1	10	1	1 = button active
Button 12, step 1	11	1	1 = button active
Button 13, step 1	12	1	1 = button active
Button 14, step 1	13	1	1 = button active
Button 15, step 1	14	1	1 = button active
Button 16, step 1	15	1	1 = button active

• Main TX buttons, step 2

SPN name	SPN start (bit)	SPN length (bit)	Description
Button 01, step 2	16	1	1 = button active
Button 02, step 2	17	1	1 = button active
Button 03, step 2	18	1	1 = button active
Button 04, step 2	19	1	1 = button active
Button 05, step 2	20	1	1 = button active
Button 06, step 2	21	1	1 = button active
Button 07, step 2	22	1	1 = button active
Button 08, step 2	23	1	1 = button active
Button 09, step 2	24	1	1 = button active
Button 10, step 2	25	1	1 = button active
Button 11, step 2	26	1	1 = button active
Button 12, step 2	27	1	1 = button active
Button 13, step 2	28	1	1 = button active
Button 14, step 2	29	1	1 = button active
Button 15, step 2	30	1	1 = button active
Button 16, step 2	31	1	1 = button active

• Main TX buttons, both steps

SPN name	SPN start (bit)	SPN length (bit)	Description
Button 01, both steps	32	1	1 = button active
Button 02, both steps	33	1	1 = button active

SPN name	SPN start (bit)	SPN length (bit)	Description
Button 03, both steps	34	1	1 = button active
Button 04, both steps	35	1	1 = button active
Button 05, both steps	36	1	1 = button active
Button 06, both steps	37	1	1 = button active
Button 07, both steps	38	1	1 = button active
Button 08, both steps	39	1	1 = button active
Button 09, both steps	40	1	1 = button active
Button 10, both steps	41	1	1 = button active
Button 11, both steps	42	1	1 = button active
Button 12, both steps	43	1	1 = button active
Button 13, both steps	44	1	1 = button active
Button 14, both steps	45	1	1 = button active
Button 15, both steps	46	1	1 = button active
Button 16, both steps	47	1	1 = button active

• **Directions**

SPN name	SPN start (bit)	SPN length (bit)	Description
Direction 01, pos negative 01	48	1	
Direction 01, pos negative 02	49	1	
Direction 01, pos positive 01	50	1	
Direction 01, pos positive 02	51	1	
Direction 02, pos negative 01	52	1	
Direction 02, pos negative 02	53	1	
Direction 02, pos positive 01	54	1	
Direction 02, pos positive 02	55	1	
Direction 03, pos negative 01	56	1	
Direction 03, pos negative 02	57	1	
Direction 03, pos positive 01	58	1	
Direction 03, pos positive 02	59	1	

B.4.3 PGN: RESERVED

B.4.4 PGN: TX ID

Transmission repetition rate	Data length (bytes)	Default priority (dec)	PGN (dec/hex)	Source address (dec/hex)	Identifier (Hex)
On change	8	6	65411/ 0xFF83	Z / 0xZZ	0x18FF83ZZ
SPN name		SPN start (bit)	SPN length (bit)	Description	
Main TX id		64	32	= 0 if no session with main TX Otherwise, = ID of main TX	

B.5 Supported PGNs Rx (Request messages accepted)

PGNs FF00h – FF03h are 64 bits each. They have an update timeout of 500ms. It accepts all source addresses.

NOTE: Transmission repetition rate is not defined by default but can be adjusted to customer needs. Contact your representative for assistance.

NOTE: "Priority" and "Source address" values are voluntary and can be adjusted to customer needs (contact your representative for assistance).

NOTE: For incoming PGNs, "Priority" and "Source address" are actually not relevant. In the table below, "Priority Y" and "Source address Z/0xZZ (dec/hex)" are therefore only used as an example for the identifier.

NOTE: It is possible to filter by "Source address", i.e. filter the incoming PGNs by source address.

B.5.1 PGN: FIELDBUS INPUT REGISTER 1 AND 2

Transmission repetition rate ¹	Data length (bytes)	Default priority (dec)	PGN (dec/hex)	Source address (dec/hex)	Identifier (Hex)
-	8	Y	65280/ 0xFF00	Z/0xZZ	0xYYFF00ZZ
SPN name		SPN start (bit)	SPN length (bit)	Description	
Generic U32 RPDO object 1		0	32	Reserved for general feedback from the CAN network (2 sub-indexes mapped to each RPDO)	
Generic U32 RPDO object 2		32	32	Reserved for general feedback from the CAN network (2 sub-indexes mapped to each RPDO)	

B.5.2 PGN: FIELDBUS INPUT REGISTER 3 AND 4

Transmission repetition rate ²	Data length (bytes)	Default priority (dec)	PGN (dec/hex)	Source address (dec/hex)	Identifier (Hex)
-	8	Y	65281/ 0xFF01	Z / 0xZZ	0xYYFF01ZZ

¹Not defined by default but can be adjusted to customer's need. Contact your representative for assistance.

²Not defined by default but can be adjusted to customer's need. Contact your representative for assistance.

SPN name	SPN start (bit)	SPN length (bit)	Description
Generic U32 RPDO object 3	0	32	Reserved for general feedback from the CAN network (2 sub-indexes mapped to each RPDO)
Generic U32 RPDO object 4	32	32	Reserved for general feedback from the CAN network (2 sub-indexes mapped to each RPDO)

B.5.3 PGN: FIELDBUS INPUT REGISTER 5 AND 6

Transmission repetition rate ¹	Data length (bytes)	Default priority (dec)	PGN (dec/hex)	Source address (dec/hex)	Identifier (Hex)
-	8	Y	65282 / 0xFF02	Z / 0xZZ	0xYYFF02ZZ

SPN name	SPN start (bit)	SPN length (bit)	Description
Generic U32 RPDO object 5	0	32	Reserved for general feedback from the CAN network (2 sub-indexes mapped to each RPDO)
Generic U32 RPDO object 6	32	32	Reserved for general feedback from the CAN network (2 sub-indexes mapped to each RPDO)

B.5.4 PGN: FIELDBUS INPUT REGISTER 7 AND 8

Transmission repetition rate ²	Data length (bytes)	Default priority (dec)	PGN (dec/hex)	Source address (dec/hex)	Identifier (Hex)
-	8	Y	65283 / 0xFF03	Z / 0xZZ	0xYYFF03ZZ

SPN name	SPN start (bit)	SPN length (bit)	Description
Generic U32 RPDO object 7	0	32	Reserved for general feedback from the CAN network (2 sub-indexes mapped to each RPDO)
Generic U32 RPDO object 8	32	32	Reserved for general feedback from the CAN network (2 sub-indexes mapped to each RPDO)

¹Not defined by default but can be adjusted to customer's need. Contact your representative for assistance.

²Not defined by default but can be adjusted to customer's need. Contact your representative for assistance.

ANNEX C: GLOSSARY

DC

Diagnostic Coverage

FIT

Failures in time (1 FIT = 1 failure per 10^9 hours)

HFT

Hardware Fault Tolerance

MTTF

Mean Time To Failure

PFH

Probability of Failure per Hour

PL

Performance level

SFF

Safety Failure Fraction

SIL

Safety Integrity Level

ANNEX D: INDEX

A

Active Load select	64
Antenna	15

B

Base board	27
Digital outputs	31
Power supply voltage	29
Boards	25
Bus system	16

C

CANopen specifications	75
CE marking	71
Circuit board positions	25
code messages	47
Configuration menu	53
Enter menu mode	53
Connector	16
Current consumption	17

D

Dimensions	16
------------------	----

E

EIRP	15
EMCY	88
Erase all registered transmitters	69
Error indications	47
CANopen	43
J1939	45
Expansion boards	31
14-relay	35
5-relay	32

CAN	40
Digital inputs	38
RS485	41
External antenna	22
F	
FCC statement	72
FCC/IC labels	73
Function LEDs in normal operation mode	42
I	
IC Statement	72
Installation precautions	21
IP code	15
J	
J1939 specifications	93
L	
Log a transmitter out	68
Login/Logout	52
Login/Logout function	52
Logout	68
M	
Maintenance	70
Master reset	69
Menu mode	
Enter menu mode	53
Menu mode indications	46
Mounting dimensions	
External antenna	23
Receiver	19
N	
Number of channels	15

O

Operating mode 1	59
Operating mode 2	61
Operating mode 3	62
Operating modes	57
Operating temperature	15

P

Position

Bottom board	25
Expansion boards	25
Main board	25
Power supply	15
Pre-defined connection set	79

R

Radio communication	15
Radio frequency band	15
Radio frequency output power	15
Radio mode	52
Register	54
Register a BLB transmitter	66
Relay functions	52
RPDO	81

S

Safety standards	15
Set momentary/latching relay functions	55
Show settings	56
Show/ change Operating mode	57
Specifications	15
Common	15
External antenna	22
Other	16
Status and error indications	42

Status indications	
CANopen	43
J1939	45
T	
TPDO	80
U	
UKCA marking	71
W	
Warnings & restrictions	8
Installation and commission	8
Maintenance	10
Operation	10
WEEE directive	71
Weight	16

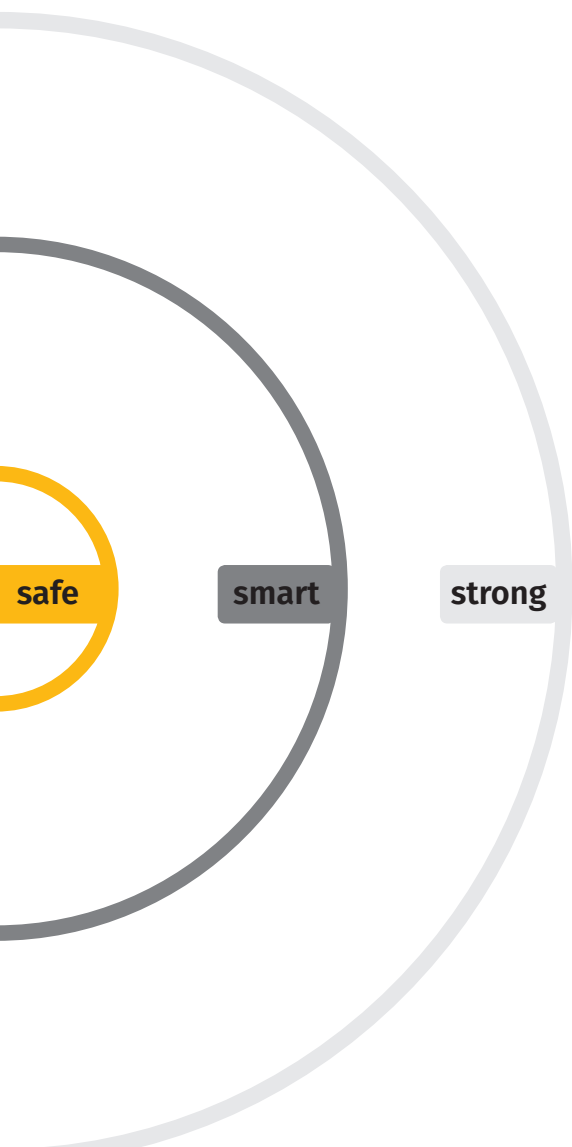

 **tele radio**[®]
wireless solutions

These Installation instructions are subject to change without prior notice.

Download the latest Installation instructions from www.tele-radio.com .