

INSTALLATION INSTRUCTIONS

Transmitter: T29-12

safe

smart

strong

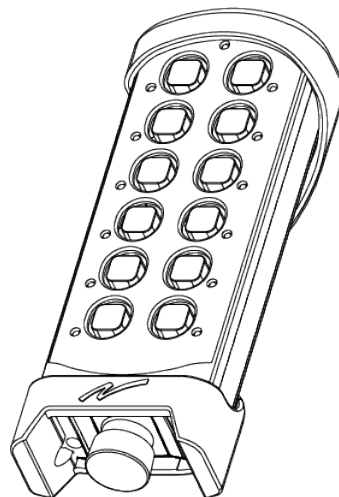

©Tele-Radio i Lysekil AB

August Barks gata 30A

SE-421 32 Västra Frölunda

Sweden

Phone: +46 (0)31 748 54 60

CHAPTER 1: INTRODUCTION	5
1.1 About this document	7
1.2 About T29 transmitters	8
CHAPTER 2: SAFETY	9
2.1 Warnings & restrictions	9
2.2 Safety features	11
CHAPTER 3: FUNCTIONAL SAFETY	12
3.1 Safety function	12
3.2 Applicable products	12
3.3 Installation	12
3.4 Configuration	12
3.5 Interface	14
CHAPTER 4: TECHNICAL DATA	15
4.1 Transmitter specifications	15
4.2 Radio frequency band	16
CHAPTER 5: PRODUCT GENERAL DESCRIPTION	17
5.1 Transmitter front	17
5.2 Transmitter back	18
CHAPTER 6: STATUS AND ERROR INDICATIONS	19
6.1 Top LED status indication	19
6.2 Stop button error indications	19
6.3 Error indications and code messages	21
CHAPTER 7: OPERATION	24
7.1 General information	24
7.2 Radio mode	24
7.3 Functionality test	25
7.4 Start a session	26
7.5 Log the transmitter out from a receiver	27
CHAPTER 8: CONFIGURATION MENU	28
8.1 Register the transmitter in a receiver	28
8.2 Menu mode and standard settings	30
8.3 Enter menu mode	31
8.4 Replace a transmitter	32
8.5 Show current radio frequency channel	34

8.6 Set the radio inactivity timeout (automatic shutdown)	35
8.7 Load select mode	36
8.8 Logout from Menu mode	40
8.9 Select a radio frequency channel	41
8.10 Load at start-up	43
CHAPTER 9: BATTERY	44
9.1 Battery precautions	44
9.2 Battery information	46
CHAPTER 10: WARRANTY, SERVICE, REPAIRS, AND MAINTENANCE	49
CHAPTER 11: REGULATORY INFORMATION	50
11.1 Europe	50
11.2 United Kingdom	50
11.3 North America	51
11.4 Brazil	53
ANNEX A: GLOSSARY	54
ANNEX B: INDEX	55

CHAPTER 1: INTRODUCTION



READ ALL INSTRUCTIONS AND WARNINGS CAREFULLY BEFORE MOUNTING, INSTALLING, CONFIGURING AND OPERATING THE PRODUCTS.

These Installation instructions have been published by Tele Radio and are not subject to any guarantees. The Installation instructions may be withdrawn or revised by Tele Radio at any time and without further notice. Corrections and updates will be added to the latest version of the manual. Always download the Installation instructions from our website, www.tele-radio.com, for the latest available version. Keep the safety instructions for future reference.

IMPORTANT! These instructions are intended for installers and authorized service and distribution centers. The instructions containing information about the installation and configuration of the radio remote control unit on the machine are NOT intended to be passed on to the user. Only information that is needed to operate the machine correctly by radio remote control may be passed on to the user.

Tele Radio remote controls are often built into wider applications. This documentation is not intended to replace the determination of suitability or reliability of the product for specific user applications and should not be used for this purpose. It is the responsibility of any such users or integrators to perform the appropriate and complete risk analysis, evaluation and testing of the products with respect to the relevant specific application or use. Tele Radio shall not be responsible or liable for misuse of the information contained herein.

Always refer to the applicable local regulations for installation and safety requirements relating to cranes, hoists, material handling applications, lifting equipment, industrial machinery, and/or mobile hydraulic applications using Tele Radio products, e.g.:

- applicable local and industrial standards and requirements,
- applicable occupational health and safety regulations,
- applicable safety rules and procedures for the factory where the equipment is being used,
- user and safety manuals or instructions of the manufacturer of the equipment where Tele Radio remote control systems are installed.

Tele Radio Installation instructions do not include or address the specific instructions and safety warnings of the end product manufacturer.

For battery precautions, see "9.1 Battery precautions".

Tele Radio products are covered by a warranty against material, construction, or manufacturing faults. See "Chapter 10: Warranty, service, repairs, and maintenance".

1.1 About this document

Before installing or operating the product, read the corresponding documentation carefully.

Tele Radio's product range is composed of transmitters, receivers, and accessories intended for use together as a system.

These Installation instructions cover general safety issues, main technical specifications, standard installation, configuration and operating instructions, general troubleshooting and battery information. Images shown in this document are for illustrative purposes only.

Please report any error or omission in this document, as well as any improvement or amendment suggestion to td@tele-radio.com.

1.1.1 COPYRIGHT

Information in this document is subject to change without notice. No part of this publication may be reproduced, stored in a retrieval system, or transmitted in any form or by any means, electronic, photographic, mechanical (including photocopying), recording or otherwise for any purpose other than the purchaser's personal use without the written permission of Tele Radio.

1.1.2 TERM AND SYMBOL DEFINITIONS

The capitalized terms and symbol used herein shall have the following meaning:

- **WARNING:** indicates a hazardous situation which, if not avoided, could result in death or serious injury.
- **CAUTION:** indicates a hazardous situation which, if not avoided, will result in minor or moderate injury.
- **IMPORTANT:** is used for information that requires special consideration.
- **NOTE:** is used to address practices not related to physical injury.



This symbol is used to call attention to safety messages that would be assigned the signal words "WARNING" or "CAUTION".

1.2 About T29 transmitters

T29 transmitters have simplex communication. They are compatible with all Panther receivers within the same frequency range.

1.2.1 OVERVIEW OF THE AVAILABLE MODEL

Model	Number of 2-step buttons	Display	Frequency
			2.4 Ghz
T29-12	12	-	•

• Standard - Not available

CHAPTER 2: SAFETY

2.1 Warnings & restrictions



Carefully read through the following safety instructions before proceeding with the installation, configuration, operation, or maintenance of the product. Failure to follow these warnings could result in death or serious injury.

This product must not be operated without having read and understood the Installation instructions and having received the appropriate training. The purchaser of this product has been instructed how to handle the system safely. The following information is intended for use as a complement to applicable local regulations and standards.

IMPORTANT! Tele Radio remote controls are often built into wider applications.

These systems should be equipped with:

- a wired emergency stop where necessary
- a brake
- an audible or visual warning signal

2.1.1 INSTALLATION AND COMMISSIONING

IMPORTANT! Only licensed or qualified personnel should be permitted to install the product.



This radio system must not be used in areas where there is a risk of explosion.



Always switch off all electrical power from the equipment before installation procedure.



RISK OF UNINTENDED EQUIPMENT OPERATION

Only transmitters that are intended for use should be registered in the receiver.

Failure to follow these instructions could result in death, serious injury, or equipment damage.

2.1.2 OPERATION



Only qualified personnel should be permitted to access the transmitter and operate the equipment.



This equipment is not suitable for use in locations where children are likely to be present.



- **Make sure that the user satisfies the age requirements in your country for operating the equipment.**
- **Make sure that the user is not under the influence of drugs, alcohol and medications.**
- **Make sure that the user knows and follows operating and maintenance instructions as well as all applicable safety procedures and requirements.**

The user should:



- **Always test the transmitter stop button before operating it. This test should be done on each shift, without a load. See "2.2.1 Stop button".**
- **Never use a transmitter if the stop button is mechanically damaged. Contact your supervisor or representative for service immediately.**
- **Never leave the transmitter unattended.**
- **Always switch the transmitter off when not in use. Store in a safe place.**
- **Keep a clear view of the work area at all times.**

2.1.3 MAINTENANCE



Before maintenance intervention on any remote controlled equipments:

- **always remove all electrical power from the equipment.**
 - **always follow lockout procedures.**
- **Keep the safety information for future reference. Always download the Installation instructions from our website, www.tele-radio.com, for the latest available version.**

-
- If error messages are shown, it is very important to find out what caused them. Contact your representative for help.
 - The functionality of the stop button should be tested at least after every 200 hours' use (see "2.2.1 Stop button").
 - If the stop button is mechanically damaged, do not use the transmitter. Contact your supervisor or representative for service immediately.
 - Keep the product in a clean, dry place.
 - Keep contacts and antennas clean.
 - Wipe off dust using a clean, slightly damp cloth.
 - Never use cleaning solutions.
 - Check the encapsulation, foils and cable for damages. If the encapsulation or foil is damaged, moisture can cause serious damage to the electronics.

2.2 Safety features

2.2.1 STOP BUTTON

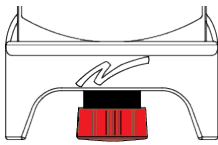

Tele Radio transmitters are equipped with a stop button.

When the **Stop** button is pressed, the stop relays on the receiver deactivate.

IMPORTANT! The Stop button should always be tested before operating the transmitter. This test should be done on each shift, without a load.

To test the stop button:

1. Press the **Stop** button.
2. Twist and release the **Stop** button.

CHAPTER 3: FUNCTIONAL SAFETY

NOTE: The information in this section applies only to the products specified below.

3.1 Safety function

The safety-related stop function in the radio system complies with **EN 13849-1:2015 PLd category 3**. The stop relays on the receiver unit are controlled by the stop button on the transmitter unit. When the stop button is pressed, the stop relays interrupt the power to the safety-related application. The complete end-user system, including the radio system, enters a safe state. The maximum response time for the safety-related stop function is 500 ms.

Safety function	Mission time	MTTFd	DC _{avg}	PFH _D	Category	Achieved PL
Stop function	20 years	100 years	99 %	$4,29 \times 10^{-08}$	3	d

3.2 Applicable products

The following receivers are **designed to comply with the appointed safety requirements when used together with a T29 transmitter**:

- **R15, R23**

NOTE: Both the receiver and the transmitter used in the specific end-user system must be compliant.

3.3 Installation

The two stop relays on the receiver unit shall be correctly installed/integrated to the end-user system requirements.

NOTE: The safety level of the stop function on the complete end-user system depends on other sub system(s) and needs to be calculated by the manufacturer of the complete system.

3.4 Configuration

The default configuration of the receiver unit complies with the appointed safety requirements. Any reconfiguration that breaches the safety requirements will be indicated by a LED on the main board of the receiver unit. Before commissioning the radio system, the installer must check the LED indication.

Function LED	Status	Indicates
PLd status LED (red)	ON	Not compliant with PLd
	OFF	Compliant with PLd

R15-01, R15-02, R15-07, R15-08

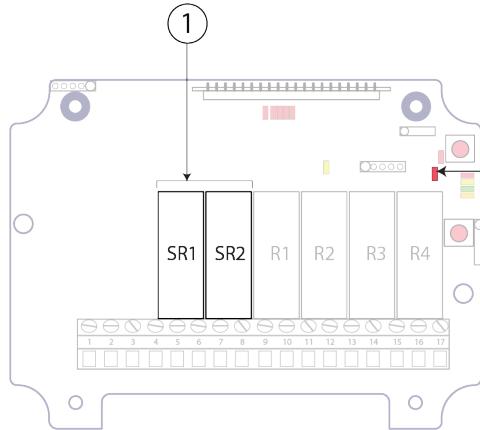

R15-13, R15-14

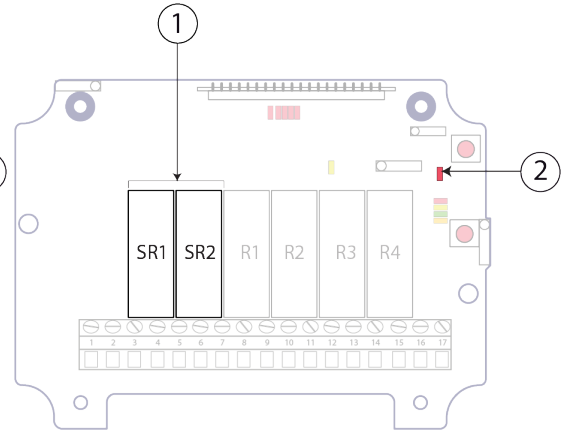

R23

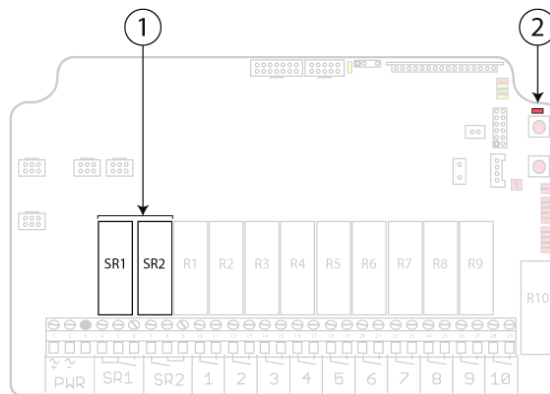

1. Stop relays SR1-2

2. PLd status LED (red)

IMPORTANT! All safety-related parameters must be configured as follows in order to comply with the appointed safety requirements:

- The system must be configured in continuous radio mode.
- The stop relays must be switched off when the radio link is down.
- The radio link timeout must be set to a maximum of 500 ms.
- The login/logout function must be activated.
- The Custom ID setting must be deactivated, i.e. the receiver must always use the unique transmitter ID code.
- The parameter 'START status in Gen1 packet for session' must be activated. See "3.4.1 'START status'/'START bit' parameters" for more

details.

- **The parameter 'START bit in Gen2 packet for session' must be activated.** See "3.4.1 'START status'/'START bit' parameters" for more details.

3.4.1 'START STATUS'/'START BIT' PARAMETERS

When the transmitter is started it will send start commands for 200 ms.

- **If both 'START status' and 'START bit' parameters are activated, the receiver is PLd compliant.**

The receiver will not activate the stop relays until it receives a start command from the transmitter. This is to make sure that the stop relays will not activate immediately if the receiver is restarted after a temporary loss of power and the transmitter is still active.

If the receiver has received a start command and the transmitter goes out of range for more than six minutes, a new start packet will be required (i.e. the transmitter will have to be restarted).

- **If one or both 'START status' or 'START bit' parameters are not checked, the receiver is NOT PLd compliant.**

The stop relays are activated as soon as the receiver receives packets without pressing any button on the transmitter.

3.5 Interface

The radio system comprises one SRP/CS (as defined in EN 13849-1:2015), including the stop button (input), the stop relays (output) and the safety-related logic maintaining the stop function (logic).

The interfaces to the SRP/CS are the stop button (as controlled by the operator) and the stop relays.

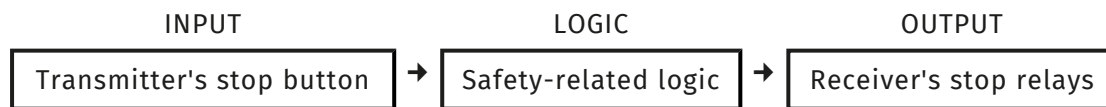

→: Interconnection

CHAPTER 4: TECHNICAL DATA

4.1 Transmitter specifications

	T29-12
Number of buttons	12 x 2-step buttons
I/O switch	No
Power supply	Replaceable, rechargeable lithium-ion battery
Operating time (with continuous usage)	Approximately 150 h with D4-02 Li-ion battery (depending on settings)
Radio communication	Simplex
Radio frequency band	2405 – 2480 MHz
Frequency management	Direct Sequence Spread Spectrum (DSSS)
Number of channels	16 (channel 11–26)
Radio frequency output power	EIRP ¹ : < 12 dBm (15.8 mW)
IP code	IP65
Operating temperature	-20...+55 °C / -4...+130 °F
Storage temperature	-30...+70 °C / -22...+158 °F (without battery) ²
Charging temperature	+10...+35 °C / +50...+95 °F
Safety levels	EN ISO 13849-1, CAT3 PLd (Stop function , see "Chapter 3: Functional safety")
Dimensions	210 x 76 x 37 mm / 8.2 x 3 x 1.4 in
Weight	400 g / 0.9 lbs

¹Equivalent isotropic radiated power. $EIRP (W) = 1.64 \times ERP (W)$ or $EIRP (dBm) = ERP (dBm) + 2.15$

²For storage temperature of battery pack M245060 (D4-02), see "9.2 Battery information".

4.2 Radio frequency band

For radio systems operating on frequency band 2.4 GHz, the frequency band is divided into 16 channels (11 to 26). Once the channel has been selected on the transmitter, the receiver will automatically detect and switch to the same channel.

Channel	Frequency (MHz)	Channel	Frequency (MHz)
11	2405	19	2445
12	2410	20	2450
13	2415	21	2455
14	2420	22	2460
15	2425	23	2465
16	2430	24	2470
17	2435	25	2475
18	2440	26	2480

CHAPTER 5: PRODUCT GENERAL DESCRIPTION

The pictures shown in this chapter are for illustrative purposes only.

5.1 Transmitter front

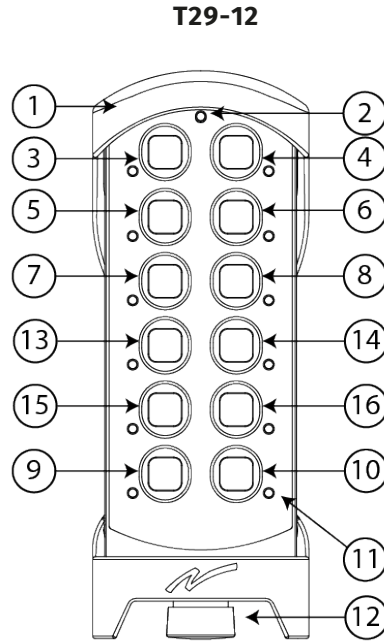

- | | | |
|-----------------|---|------------------------|
| 1. Rubber cover | 7. Button 5 | 12. Stop button |
| 2. Top LED | 8. Button 6 | 13. Button 7 |
| 3. Button 1 | 9. Button 11 / Left Start button | 14. Button 8 |
| 4. Button 2 | 10. Button 12 / Right Start button | 15. Button 9 |
| 5. Button 3 | 11. Button LEDs | 16. Button 10 |
| 6. Button 4 | | |

5.1.1 SHIFT BUTTON

In some cases, the **right Start** button is used as a shift button to access some menus and/or channels.

To activate the shift function, press the shift button and keep it pressed. Press the button corresponding to the desired channel/ menu. Release it, then release the shift button.

5.1.2 TOP LED

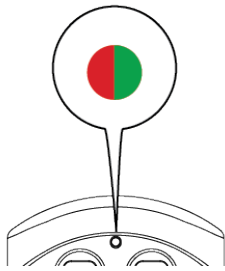

The transmitter is equipped with one bi-color LED (top LED) for battery indication and radio link information. For more details, see "Chapter 6: Status and error indications"

5.2 Transmitter back

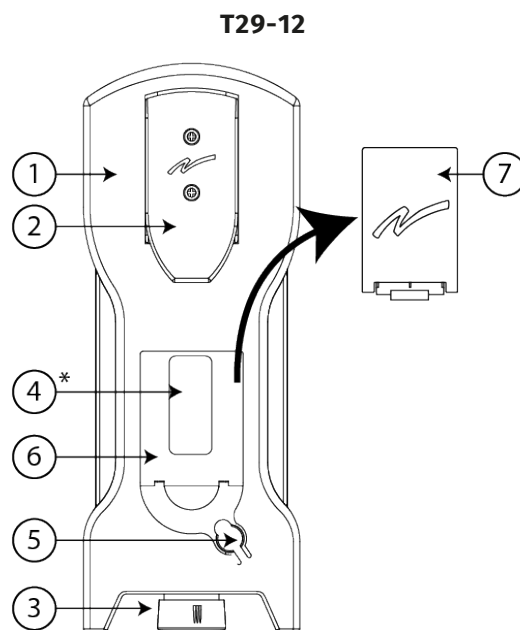

- | | | |
|-----------------------|-------------------------------|------------------------|
| 1. Rubber cover | 4. Product label ¹ | 6. Battery compartment |
| 2. Clip | 5. Battery charger socket | 7. Replaceable battery |
| 3. Stop button | | |

¹*The product label is placed inside the battery compartment.

CHAPTER 6: STATUS AND ERROR INDICATIONS

6.1 Top LED status indication

The top LED flashes green when the battery capacity is good and red when the battery capacity is poor. When the top LED lights/flashes red, battery should be charged or changed at the next convenient opportunity (see "9.2.1 Charge the battery").

6.2 Stop button error indications

The **Stop** button must be tested if one of the following errors occurs when pulling out the **Stop** button to start the transmitter:

- FATAL_ERROR_STOP_BUTTON_FAILED
(top LED is flashing red/green, LEDs 1+2 are lit, all other LEDs are off)
- FATAL_ERROR_CPU2_STUCK_IN_SAFETY
(top LED is flashing red/green, LEDs 2+4 are lit, all other LEDs are off)
- FATAL_ERROR_STOP_BUTTON_CPU1_ADC_VALUE_INVALID
(top LED is flashing red/green, LEDs 3+4 are lit, all other LEDs are off)
- FATAL_ERROR_STOP_BUTTON_INCONSISTENT
(top LED is flashing red/green, LEDs 1+3+4 are lit, all other LEDs are off)

6.2.1 TEST THE STOP BUTTON

NOTE: A test of the stop button is required in both "pulled out" and "pressed in" positions.

1. Press the **Stop** button.

If the transmitter turns off	If the transmitter doesn't turn off
<i>The test succeeded.</i>	<i>The test failed.</i>
Proceed to next step.	<ol style="list-style-type: none">1. Disassemble the transmitter2. Check the stop button and replace if necessary.3. Check the cables from the stop button to the transmitter board.4. Proceed to next step.

2. Twist and release the **Stop** button.

If the transmitter turns on.	If the transmitter doesn't turn on
<i>The test succeeded.</i>	<i>The test failed.</i>
The transmitter can be used.	Go back to step 1 and try again.

6.3 Error indications and code messages

Each error is identified by a code indicated by a LED combination including the top LED (LED 0) and button LEDs 1–5.

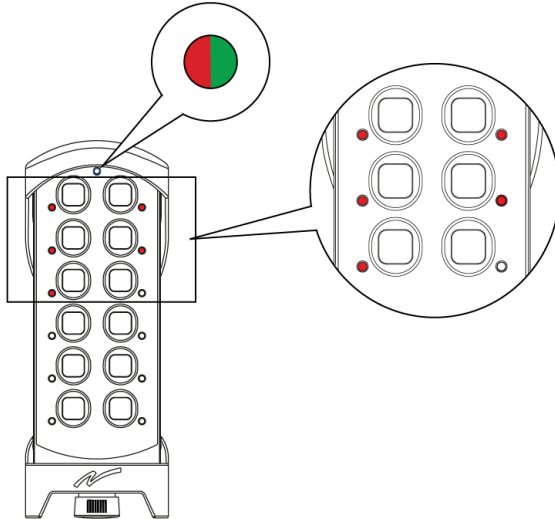

⊙: LED is blinking green/red. ●: LED is lit (red). ○: LED is off.

LED0 green/red	LED1 red	LED2 red	LED3 red	LED4 red	LED5 red	Error code	Indicates
⊙	●	○	○	○	○	FATAL_ERROR_ NO_ PRODUCTION_ DATA_RECEIVED_ CPU1	'No production data received from CPU1' For this error code, contact technical support
⊙	○	●	○	○	○	FATAL_ERROR_ FAILED_RADIO_ INIT	'Radio initialization has failed' For this error code, contact technical support
⊙	●	●	○	○	○	FATAL_ERROR_ STOP_BUTTON_ FAILED	'Stop button failure' Test the stop button (see "6.2.1 Test the Stop button"). If failed, contact technical support
⊙	○	○	●	○	○	FATAL_ERROR_ CPU2_POWER_ OFF_RADIO	'CPU2 will power off the radio module' For this error code, contact technical support

LED0 green/red	LED1 red	LED2 red	LED3 red	LED4 red	LED5 red	Error code	Indicates
⊙	●	○	●	○	○	FATAL_ERROR_PNG2_MODULE_INCONSISTENCY	'Wrong Stop button status during memory test' (during memory test, the stop button status saved in memory is different from the one created when building the radio package). For this error code, contact technical support.
⊙	○	●	●	○	○	FATAL_ERROR_FLOW_CONTROL	'SW error (flow control error)' For this error code, contact technical support
⊙	●	●	●	○	○	FATAL_ERROR_CPU2_PROBING	'No answer from CPU2' For this error code, contact technical support
⊙	○	○	○	●	○	FATAL_ERROR_CPU2_INCORRECT_SW	'Incompatible SW version (CPU2)' For this error code, contact technical support
⊙	●	○	○	●	○	FATAL_ERROR_CPU2_LOST	'No communication with CPU2' For this error code, contact technical support
⊙	○	●	○	●	○	FATAL_ERROR_CPU2_STUCK_IN_SAFETY	'Conflict between CPU2 and CPU1 about Stop button status' Stop and restart the transmitter. Test the stop button (see "6.2.1 Test the Stop button"). If failed, contact technical support
⊙	●	●	○	●	○	FATAL_ERROR_STOP_BUTTON_MEMORY	'Wrong Stop button status during memory test' (the stop button status saved in memory is different from the one created when building the radio package). For this error code, contact technical support.

LED0 green/red	LED1 red	LED2 red	LED3 red	LED4 red	LED5 red	Error code	Indicates
⊙	○	○	●	●	○	FATAL_ERROR_STOP_BUTTON_CPU1_ADC_VALUE_INVALID	'Stop button is returning a incorrect value' Test the stop button (see "6.2.1 Test the Stop button"). If failed, contact technical support
⊙	●	○	●	●	○	FATAL_ERROR_STOP_BUTTON_INCONSISTENT	'The Stop button is not working properly' Test the stop button (see "6.2.1 Test the Stop button"). If failed, contact technical support
⊙	○	●	●	●	○	FATAL_ERROR_RADIO_CONFIG_NEGATIVE_TEST	'CPU1 can access radio without CPU2 authorization' For this error code, contact technical support
⊙	●	●	●	●	○	FATAL_ERROR_RF_RESET_PIN_NOT_RELEASED	'CPU2 is wrongly preventing CPU1 to access radio ' For this error code, contact technical support
⊙	○	○	○	○	●	FATAL_ERROR_ADC_NOT_WORKING	'ADC Error' (CPU1 cannot complete the board's parameter check) For this error code, contact technical support

CHAPTER 7: OPERATION

7.1 General information

To control a receiver, the transmitter must be registered and logged in to the receiver. If another transmitter is already logged in to the receiver, it must be logged out before a different transmitter can be logged in.

If no transmitter is logged in to the receiver, proceed with the login procedure before using the system. Once a transmitter has been logged in, it will remain logged in until it is manually logged out.

More than one transmitter can be registered in the receiver, but only one transmitter can be logged in at a time.

7.2 Radio mode

NOTE: To establish a radio link between the transmitter and the receiver, both units must be set to the same radio mode.

This transmitter is set to **continuous** radio mode. The transmitter starts to transmit continuously as soon as it is started. The radio transmission ends when the stop button is pressed. Buttons 11 and 12 are used as start buttons.

Discontinuous radio mode is not available for this transmitter.

7.3 Functionality test

NOTE: This list is intended for use as a support for the manufacturer of the equipment where Tele Radio remote control systems are installed.

Before operating the radio system, follow the procedure below.

IMPORTANT! This test should be performed at each shift, without a load, and should include but not be limited to the following steps

- Make sure that the controlled object can not cause any harm in the event of unexpected movement.
- Always follow local safety rules and start the equipment according to the corresponding instructions.
- Make sure that the transmitter can control the receiver by testing all functions.
- Make sure that the functions respond as expected.
- Make sure that all movements are as planned.
- Make sure that the stop button works correctly.
- Make sure that the stop function works correctly.
- Make sure the system stops when the battery is removed from the transmitter.

7.4 Start a session

To be able to control a receiver with the transmitter, the transmitter must be registered in the receiver.

When starting the transmitter, it will automatically log in to the receiver(s) it has been registered in, provided that no other transmitter is already logged in to the receiver(s). If the transmitter was not logged out after the last session, it will remain logged in when starting a new session.



When not in use, transmitters must be switched off and stored in a secure storage space.



Do not use the system if the stop button is damaged or if it does not stop the equipment. Doing so could result in serious injury or death.

1. Make sure that the **Stop** button is pressed.
2. Twist and release the **Stop** button.
The top LED lights. LEDs 11 and 12 flash (red).
3. Press buttons 11 and 12 simultaneously for at least 1 second.
LEDs 11 and 12 light (red).
4. Release buttons 11 and 12.
LEDs 11 and 12 go out. The top LED flashes.
5. Proceed with the functional test (see "7.3 Functionality test").

7.5 Log the transmitter out from a receiver

IMPORTANT! For the logout function to work, BOTH the receiver and the transmitter must have the logout function activated and be set to continuous radio mode.

A transmitter already logged in to the receiver has to be logged out before any other transmitter can be logged in. If a transmitter has been lost or seriously damaged, use the replace procedure on the transmitter.

NOTE: Logout can only be performed when the transmitter is on and a radio link with one or more receivers has been established. The receiver must be powered-up for the logout procedure to be successful.

NOTE: The logout procedure will log the transmitter out from all receivers that are part of the radio session.

NOTE: The logout function cannot be activated/deactivated from the transmitter. Contact your representative for assistance.

For this transmitter, the logout function is activated by default.¹

7.5.1 QUICK LOGOUT

While the transmitter is in a session (i.e. transmitter started and radio link with the receiver established):

1. Press and hold button 11.
2. Press the **Stop** button.
The top LED lights (red).
3. Release button 11.
The transmitter takes approximately 3 seconds to logout. The transmitter turns off.

It is also possible to log out from the **Menu mode**, see "8.8 Logout from Menu mode".

¹Check the receiver installation instructions for more details about the logout function in the receiver.

CHAPTER 8: CONFIGURATION MENU

8.1 Register the transmitter in a receiver

8.1.1 PREREQUISITE

NOTE: The registration instructions require access to the receiver circuit board. Before starting the registration of a transmitter, prepare the receiver as follow:

RISK OF ELECTRIC SHOCK

The receiver must only be opened by qualified installers or authorized personnel.



Make sure the power supply is switched off before opening the receiver. Failure to follow these instructions could result in death, serious injury, or equipment damage.

1. Remove the front cover of the receiver. Use a screwdriver to remove the screws.
2. Power the receiver up.
The Power LED lights (yellow).
3. Proceed with the registration procedure for the corresponding receiver.

8.1.2 REGISTER THE TRANSMITTER

RISK OF UNINTENDED EQUIPMENT OPERATION

Only transmitters that are intended for use should be registered in the receiver.



Failure to follow these instructions could result in death, serious injury, or equipment damage.

RISK OF UNINTENDED EQUIPMENT OPERATION

Do not perform this action when the receiver is in a session with another transmitter. The radio communication may be interrupted or broken.



Failure to follow these instructions could result in death, serious injury, or equipment damage.

NOTE: For the registration procedure to be successful, the receiver must be powered up.

NOTE: To establish a radio link between the transmitter and the receiver, both units must be set to the same radio mode.

1. Make sure that the **Stop** button is pressed.
2. Twist and release the **Stop** button.
The top LED lights (green when the battery capacity is good, red when the battery capacity is poor). The LEDs next to both start buttons flash (red).
3. Press and hold both **Start** buttons simultaneously for one second.
The LEDs next to both start buttons light (red).
4. Release both **Start** buttons.
The LEDs next to both start buttons go out. The top LED flashes (green).

ON THE RECEIVER¹

5. Press the receiver **Function** button.
6. Press the receiver **Select** button.

ON THE TRANSMITTER

7. Press and hold buttons 1 and 2².
8. Release buttons 1 and 2.
The transmitter is registered.

If no transmitter is found within approximately 10 seconds, the receiver exits to normal operation. Go back to step 1 and try again.

¹See the receiver installation instructions for more detailed information.

²Default buttons.

8.2 Menu mode and standard settings

The **Menu mode** allows for certain settings to be set directly from the transmitter. Once in **Menu mode**, the following menus will be available.

In some cases, the **right Start** button¹ is used as a shift button to access some menus and channels.

To activate the shift function, press the shift button and keep it pressed. Press the button corresponding to the desired menu/ channel number. Release it, then release the shift button.

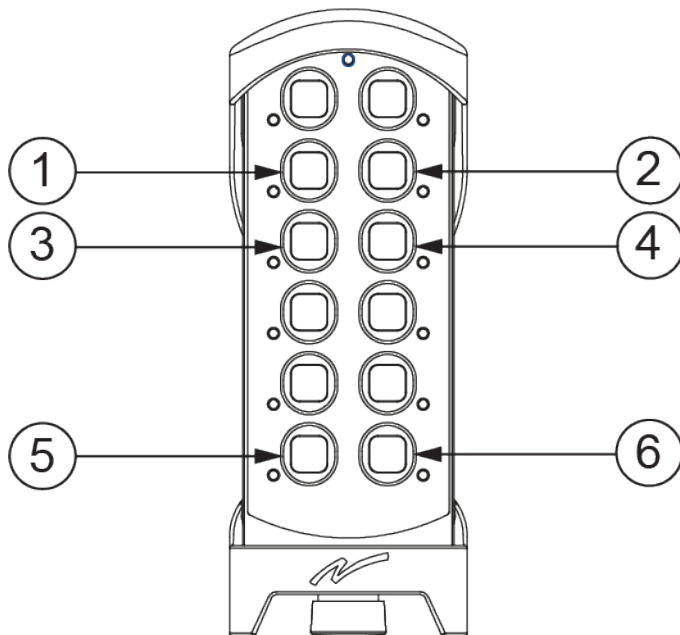

1	Replace	Replace a lost or damaged transmitter
2	Show channel	Show the channel currently used
3	Automatic shutdown	Enable/Disable the auto-shutdown option
4	Load select mode	Select a load option (0-8)
5	Logout	Log out the transmitter from a receiver
6 + 2	Switch channel	Select the channel to use
6 + 4	Load at start-up	Select the default load at start up

¹T29-12: button 12.

8.3 Enter menu mode

1. Make sure that the **Stop** button is pressed.
2. Press and hold button 12.
3. Twist and release the **Stop** button.
4. Release button 12.
The top LED flashes (green).

WITHIN 1 MINUTE OF RELEASING THE STOP BUTTON:

5. Press buttons 1, 2, 3, 4 in sequence to enter **Menu mode**.
The top LED flashes (green) and LEDs 3–6 flash (red).
If the code is invalid, the transmitter turns off. Go back to step 1 and try again.

WITHIN 1 MINUTE OF ENTERING THE CODE:

6. Select a menu by pressing a button according to the following table.

Menu	T29-12
Replace	Button 3
Show channel	Button 4
Automatic shutdown	Button 5
Load select mode	Button 6
Logout	Button 11
Switch channel	Press and hold button 12 (shift) + press button 4
Load at start-up	Press and hold button 12 (shift) + press button 6

If no buttons are pressed within 1 minute, the transmitter will turn off.

8.4 Replace a transmitter

It is possible to replace a registered transmitter with another transmitter of the same model¹. The procedure does not require to open the receiver housing but the receiver needs to be powered up and within transmission range.

RISK OF UNINTENDED EQUIPMENT OPERATION



Do not perform this action when the receiver is in a session with another transmitter. The radio communication may be interrupted or broken.

Failure to follow these instructions could result in death, serious injury, or equipment damage.



The replacement transmitter will control all receivers it has been registered in, provided that no other transmitter is logged in.

IMPORTANT! Before replacing a damaged or missing transmitter with a new one, check if the transmitter used as replacement is already registered in any other receiver. If necessary, erase the transmitter from other receivers before performing the replacement procedure.

NOTE: The serial number (SN) is written on the product label located in the battery compartment of the transmitter, see "5.2 Transmitter back".

IMPORTANT! When entering the last digit of the serial number, keep the button pressed until after the stop button is pressed.

1. Make sure that the **Stop** button is pressed.
2. Press and hold button 12.
3. Twist and release the **Stop** button.
4. Release button 12.
The top LED flashes (green).

WITHIN 1 MINUTE OF RELEASING THE STOP BUTTON:

5. Press buttons 1, 2, 3, 4 in sequence to enter **Menu mode**.

¹To replace a T29 with another transmitter model, please contact your representative for assistance.

The top LED flashes (green) and LEDs 3–6 flash (red).

If the code is invalid, the transmitter turns off. Go back to step 1 and try again.

WITHIN 1 MINUTE OF ENTERING THE CODE:

6. Press button 3 to enter the [Replace] menu.
The top LED lights (green). LED 2 flashes (red).
7. Enter the first digit of the serial number (SN) **of the transmitter to be replaced** (i.e. the old, lost or damaged transmitter). The transmitter buttons 1–8 correspond to digits 1–8.
LED 3 lights (red) when a valid digit has been entered.
8. Repeat step 7 until the penultimate digit.
9. Enter the last digit of the serial number (SN) **and keep the button pressed**.
LEDs 3 and 4 light (red) when the maximum number of digits (11) has been entered.
10. Press the **Stop** button.
11. Release the button of the last digit.
After approximately 10 seconds the transmitter turn off.

NOTE: If the button for the serial number's last digit is not pressed while pressing the **Stop** button, the transmitter will exit the Replace menu without sending the replace command.

8.5 Show current radio frequency channel

1. Make sure that the **Stop** button is pressed.
2. Press and hold button 12.
3. Twist and release the **Stop** button.
4. Release button 12.
The top LED flashes (green).

WITHIN 1 MINUTE OF RELEASING THE STOP BUTTON:

5. Press buttons 1, 2, 3, 4 in sequence to enter **Menu mode**.
The top LED flashes (green) and LEDs 3–6 flash (red).
If the code is invalid, the transmitter turns off. Go back to step 1 and try again.

WITHIN 1 MINUTE OF ENTERING THE CODE:

6. Press button 4 to enter the [Show channel] menu.
The top LED lights (green).
LED 1 flashes a number of times corresponding to the first digit.
*LED 2 flashes a number of times corresponding to the second digit.*¹
The sequence is repeated six times.

¹Example: For channel 23, LED 1 will flash 2 times, LED 2 will flash 3 times.

8.6 Set the radio inactivity timeout (automatic shutdown)

NOTE: Only for **continuous** radio mode.

Set the off delay (in seconds) before the transmitter automatically turns off. Automatic shutdown helps prolong battery capacity by automatically turning the transmitter off after a preset period of inactivity.

1. Make sure that the **Stop** button is pressed.
2. Press and hold button 12.
3. Twist and release the **Stop** button.
4. Release button 12.
The top LED flashes (green).

WITHIN 1 MINUTE OF RELEASING THE STOP BUTTON:

5. Press buttons 1, 2, 3, 4 in sequence to enter **Menu mode**.
The top LED flashes (green) and LEDs 3–6 flash (red).
If the code is invalid, the transmitter turns off. Go back to step 1 and try again.

WITHIN 1 MINUTE OF ENTERING THE CODE:

6. Press button 5 to enter the [Automatic shutdown] menu.
The top LED lights (green). LED 2 flashes (red).
7. Select the automatic shutdown time by pressing a button according to the following table.

Automatic shutdown time	T29-12
3 minutes	Button 1
6 minutes	Button 2
12 minutes	Button 3
No automatic shutdown	Button 11

The top LED flashes (green) 3 times. The transmitter turns off.

8.7 Load select mode

NOTE: Only for **continuous** radio mode.

1. Make sure that the **Stop** button is pressed.
2. Press and hold button 12.
3. Twist and release the **Stop** button.
4. Release button 12.
The top LED flashes (green).

WITHIN 1 MINUTE OF RELEASING THE STOP BUTTON:

5. Press buttons 1, 2, 3, 4 in sequence to enter **Menu mode**.
The top LED flashes (green) and LEDs 3–6 flash (red).
If the code is invalid, the transmitter turns off. Go back to step 1 and try again.

WITHIN 1 MINUTE OF ENTERING THE CODE:

6. Press button 6 to enter the [Load select mode] menu.
The top LED lights (green). LED 2 flashes (red).
7. Select a **Load select** mode by pressing a button according to the following table.

Load select mode	Default load selected at start-up ¹	Buttons
0 (default)	none	Button 11
1	A	Button 1
2	A	Button 2
3	A	Button 3
4	A	Button 4
5	A	Button 5
6	A	Button 6
7	A	Button 7
8	A	Button 8

The top LED flashes (green) 3 times. The transmitter turns off.

¹Load at start-up can be changed later on, see "8.10 Load at start-up".

8.7.1 LOAD SELECT MODE 0-8

Load select mode 0

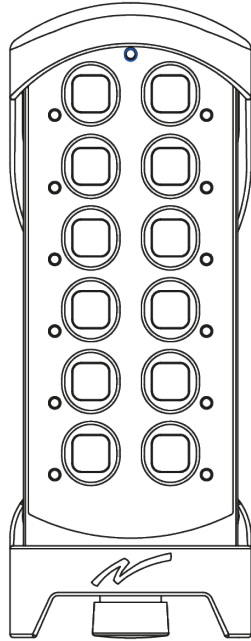

Load select mode 1

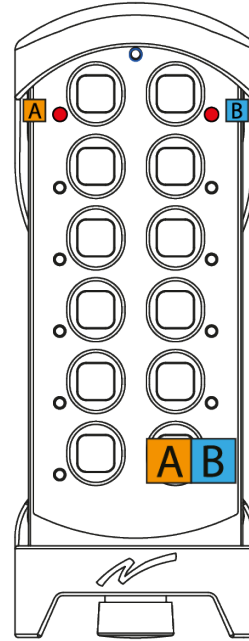

Load select mode 2

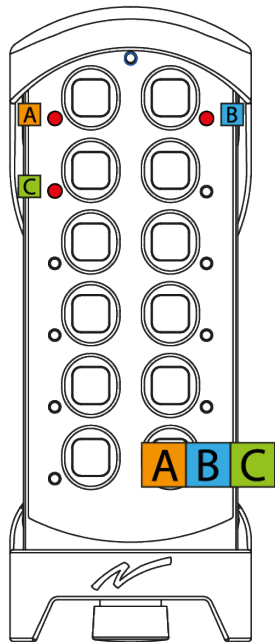

Load select mode 3

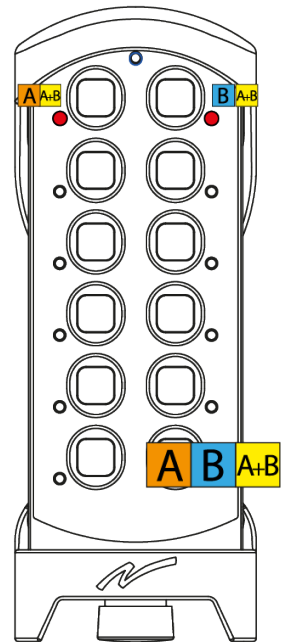

Load select mode 4

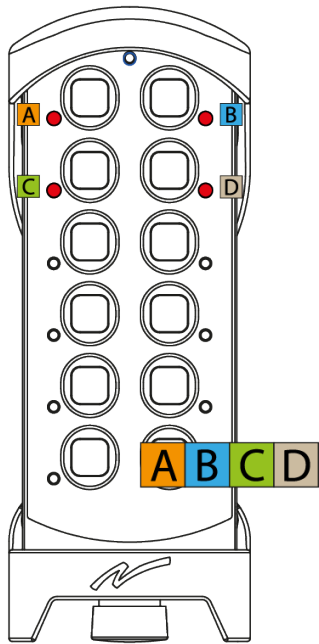

Load select mode 5

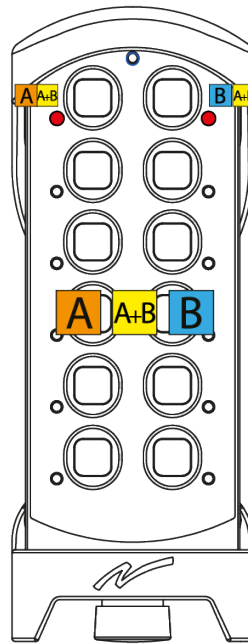

Load select mode 6

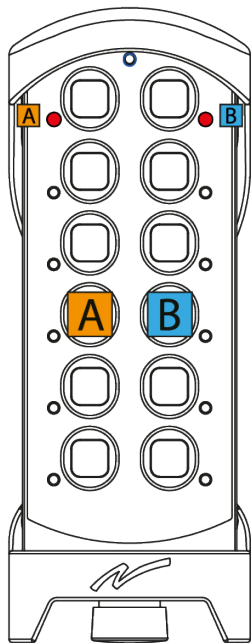

Load select mode 7

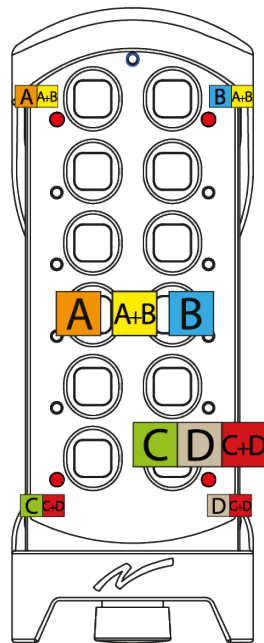

Load select mode 8

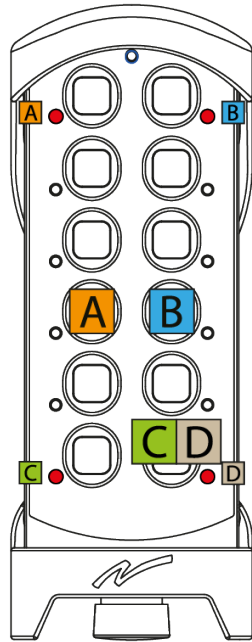

8.8 Logout from Menu mode

This logout option is mainly used when the button for quick logout is used by another function.

IMPORTANT! For the logout function to work, BOTH the receiver and the transmitter must have the logout function activated and be set to continuous radio mode.

NOTE: Logout can only be performed when the transmitter is on and a radio link with one or more receivers has been established. The receiver must be powered-up for the logout procedure to be successful.

1. Make sure that the **Stop** button is pressed.
2. Press and hold button 12.
3. Twist and release the **Stop** button.
4. Release button 12.
The top LED flashes (green).

WITHIN 1 MINUTE OF RELEASING THE STOP BUTTON:

5. Press buttons 1, 2, 3, 4 in sequence to enter **Menu mode**.
The top LED flashes (green) and LEDs 3–6 flash (red).
If the code is invalid, the transmitter turns off. Go back to step 1 and try again.

WITHIN 1 MINUTE OF ENTERING THE CODE:

6. Press button 11
The top LED flashes (red).
The transmitter takes approximately 10 seconds to logout. The transmitter turns off.

8.9 Select a radio frequency channel

1. Make sure that the **Stop** button is pressed.
2. Press and hold button 12.
3. Twist and release the **Stop** button.
4. Release button 12.
The top LED flashes (green).

WITHIN 1 MINUTE OF RELEASING THE STOP BUTTON:

5. Press buttons 1, 2, 3, 4 in sequence to enter **Menu mode**.
The top LED flashes (green) and LEDs 3–6 flash (red).
If the code is invalid, the transmitter turns off. Go back to step 1 and try again.

WITHIN 1 MINUTE OF ENTERING THE CODE:

6. Press and hold button 12.
7. Press button 4.
8. Release button 4.
9. Release button 12.
The top LED lights (green). LED 2 flashes (red). The transmitter enters the [Switch channel] menu.
10. Enter the first digit of the new channel (11–26) by pressing the buttons according to the following table.¹

Digits	Buttons
1	Button 1
2	Button 2
3	Button 3
4	Button 4
5	Button 5

Digits	Buttons
6	Button 6
7	Button 7
8	Button 8
9	Button 9
0	Button 10

LED 3 lights (red) when a valid digit has been entered.

¹For example channel 20: Press button 2 for the first digit. For zero, press button 10.

11. Enter the second digit.

LED 4 lights (red) when a valid digits has been entered.

The top LED flashes (green) 3 times. The transmitter turns off.

To check that the channel has been properly changed, see "8.5 Show current radio frequency channel".

8.10 Load at start-up

NOTE: Make sure to have a **Load select** mode selected before following the instructions below.

1. Make sure that the **Stop** button is pressed.
2. Press and hold button 12.
3. Twist and release the **Stop** button.
4. Release button 12.
The top LED flashes (green).

WITHIN 1 MINUTE OF RELEASING THE STOP BUTTON:

5. Press buttons 1, 2, 3, 4 in sequence to enter **Menu mode**.
The top LED flashes (green) and LEDs 3–6 flash (red).
If the code is invalid, the transmitter turns off. Go back to step 1 and try again.

WITHIN 1 MINUTE OF ENTERING THE CODE:

6. Press and hold button 12.
7. Press button 6.
8. Release button 6.
9. Release button 12.
The top LED lights (green). LED 2 flashes (red). The transmitter enters the [Load at start-up] menu.
10. Select the load at start-up by pressing a button according to the following table.

Load at start-up	T29-12
A	Button 1
B	Button 2
A+B	Button 3
none	Button 11

The top LED flashes (green) 3 times. The transmitter turns off.

CHAPTER 9: BATTERY

9.1 Battery precautions

Carefully read the following safety instructions and warnings before using, charging or disposing of the batteries.



Batteries contain flammable substances such as lithium or other organic solvents, which may result in overheating, rupture or combustion. Failure to read and follow the below instructions may result in fire, personal injury and damage to property if charged or used improperly.

9.1.1 HANDLING AND STORAGE



- Risk of explosion if battery is replaced with a battery of an incorrect type.
- Do not short-circuit, disassemble, deform or heat batteries.
- Never attempt to charge a visibly damaged or frozen battery.
- Do not use or charge the battery if it appears to be leaking, deformed or damaged in any way.
- Do not solder directly onto batteries.
- Do not leave the battery in the charger once it is fully charged.
- Store in a cool location. Keep batteries away from direct sunlight, high temperature, and high humidity.
- Immediately discontinue use of the battery if, while using, charging, or storing the battery, the battery emits an unusual smell, feels hot, changes color, changes shape, or appears abnormal in any other way.
- Keep batteries out of reach of small children. Should a child swallow a battery, consult a physician immediately.

9.1.2 DISPOSAL

When discarding batteries, insulate the + and - terminals of batteries with insulating/ masking tape.



- **Do not place multiple batteries in the same plastic bag.**
- **Do not incinerate or dispose of batteries in fire.**
- **Do not place used batteries in the household waste. Dispose of used batteries in accordance with the applicable regulations and legal requirements.**
- **Batteries that have been disposed of incorrectly may short circuit, causing them to become hot, burst or ignite.**

9.2 Battery information

NOTE: Only batteries approved by Tele Radio should be used in T29 transmitters.

NOTE: When the battery capacity reaches approximately 10 %, the top LED lights red.

	T29-12	
Type of battery	Replaceable, rechargeable lithium-ion battery, 3.7 V/1600 mAh	
Article number	M245060 (D4-02)	
Charge	Charger plug on the back of the transmitter	Charger unit (D4-01)
Charger ¹	Tele Radio AC adapter	Tele Radio charger unit together with Tele Radio AC adapter
Article number	M769780	M769755 (D4-01) + M769780
Charging time	Approximately 3 hours with an empty battery	
Charging temperature	+10...+35 °C / +50...+95 °F	
Storage temperature	-20...+55 °C / -4...+130 °F	

¹Must be purchased separately.

9.2.1 CHARGE THE BATTERY

Battery D4-02 can be charged directly on the transmitter with an AC adapter, or in the table charger D4-01/M769755. For more information, see "9.2 Battery information".

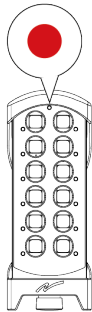

When the battery capacity reaches approximately 10 %, the top LED lights red.

Charging on the transmitter

1. Lift the protection cap.
2. Insert the charger plug into the socket on the back of the transmitter.

The top LED flashes red while the battery is charging.

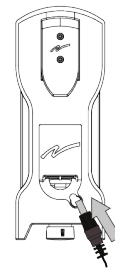

The top LED flashes green when the battery is fully charged.

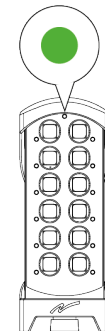

3. Remove the charger plug and close the protection cap.

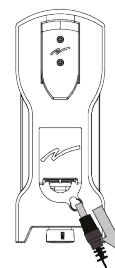

Charging using the charger unit

1. Remove the rubber cover from the transmitter.
2. Remove the battery from the transmitter
3. Place the battery in the charger.
The charger's LED lights red while the battery is charging.

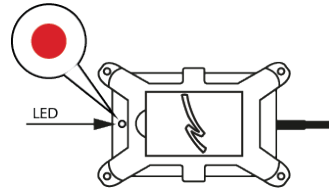

The charger's LED turns green when the battery is fully charged.

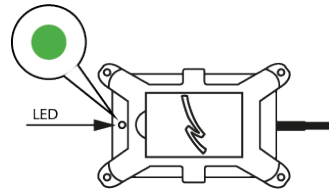

4. Remove the battery from the charger unit.
5. Put the battery back in the transmitter
The top LED flashes green when the battery is fully charged.

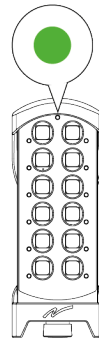

CHAPTER 10: WARRANTY, SERVICE, REPAIRS, AND MAINTENANCE

Tele Radio products are covered by a warranty against material, construction and manufacturing faults. During the warranty period, Tele Radio may replace the product or faulty parts. Work under warranty must be performed by Tele Radio or by an authorized service center specified by Tele Radio.

The following are **not** covered by the warranty:

- Faults resulting from normal wear and tear
- Parts of a consumable nature
- Products that have been subject to unauthorized modifications
- Faults resulting from incorrect installation and use
- Damp and water damage

Maintenance

- Repairs and maintenance must be performed by qualified personnel
- Only use spare parts from Tele Radio
- Contact your representative for service or any other assistance
- Keep the product in a clean, dry place
- Keep contacts and antennas clean
- Wipe off dust using a slightly damp, clean cloth

NOTE: Never use cleaning solutions or high-pressure washer.

CHAPTER 11: REGULATORY INFORMATION

NOTE: Models including additional naming conventions:

Model	Article names	Additional naming conventions
T29	T29-12	T00029-12, PN-T29-12

11.1 Europe

Applies to: **T29, T29-12**

11.1.1 CE MARKING

 Hereby, Tele-Radio i Lysekil AB, declares that the product(s) listed above is/are in compliance with the Radio Equipment Directive 2014/53/EU.

The latest version of the complete EU Declaration of Conformity is available at the following website: www.tele-radio.com.

11.1.2 WEEE DIRECTIVE



This symbol means that inoperative electrical and electronic products must not be mixed with household waste. The European Union has implemented a collection and recycling system for which producers are responsible. For proper treatment, recovery and recycling, please take this product to a designated collection point.

Tele Radio strives to minimize the use of hazardous materials, promotes reuse and recycling, and reduces emissions to air, soil and water. When a commercially viable alternative is available, Tele Radio strives to restrict or eliminate substances and materials that pose an environmental, health or safety risk.

11.2 United Kingdom

Applies to:

T29, T29-12

11.2.1 UKCA MARKING



UK Importer: Tele Radio (UK) LTD
1 SEYMOUR COURT,
MANOR PARK, RUNCORN, WA7 1SY, UK
Email: sales@teleradiouk.com

11.3 North America

Applies to: **T29, T29-12**

11.3.1 FCC STATEMENT

This device complies with part 15 of the FCC Rules. Operation is subject to the following two conditions:

- (1) This device may not cause harmful interference, and
- (2) this device must accept any interference received, including interference that may cause undesired operation.

Changes or modifications not expressly approved by the party responsible for compliance could void the user's authority to operate the equipment.

This equipment has been tested and found to comply with the limits for a Class B digital device, pursuant to part 15 of the FCC Rules. These limits are designed to provide reasonable protection against harmful interference in a residential installation. This equipment generates uses and can radiate radio frequency energy and, if not installed and used in accordance with the instructions, may cause harmful interference to radio communications. However there is no guarantee that interference will not occur in a particular installation. If this equipment does cause harmful interference to radio or television reception, which can be determined by turning the equipment off and on, the user is encouraged to try to correct the interference by one or more of the following measures:

- Reorient or relocate the receiving antenna.
- Increase the separation between the equipment and receiver.
- Connect the equipment into an outlet on a circuit different from that to which the receiver is connected.
- Consult the dealer or an experienced radio/TV technician for help.

11.3.2 IC STATEMENT

This product complies with Industry Canada's licence-exempt RSSs. Operation is subject to the following two conditions:

- (1) This device may not cause interference; and
- (2) This device must accept any interference, including interference that may cause undesired operation of device.

Le présent appareil est conforme aux CNR d'Industrie Canada applicables aux appareils radio exempts de licence. L'exploitation est autorisée aux deux conditions suivantes :

- 1) l'appareil ne doit pas produire de brouillage;
- 2) l'appareil doit accepter tout brouillage radioélectrique subi, même si le brouillage est susceptible d'en compromettre le fonctionnement.

11.3.3 FCC/IC LABELS

The FCC and IC numbers are found on the product label.

“Contains FCC ID: ONFC2107A”

“Contains IC: 4807A-C2107A”

11.4 Brazil

Applies to: **T29, T29-12**

11.4.1 ANATEL STATEMENT (DECLARAÇÃO ANATEL)

Este equipamento não tem direito à proteção contra interferência prejudicial e não pode causar interferência em sistemas devidamente autorizados.

Este produto não é apropriado para uso em ambientes domésticos, pois poderá causar interferências eletromagnéticas que obrigam o usuário a tomar medidas necessárias para minimizar estas interferências.

ANNEX A: GLOSSARY

DC

Diagnostic Coverage

FIT

Failures in time (1 FIT = 1 failure per 10^9 hours)

HFT

Hardware Fault Tolerance

MTTF

Mean Time To Failure

PFH

Probability of Failure per Hour

PL

Performance level

SFF

Safety Failure Fraction

ANNEX B: INDEX

A

ANATEL Statement	53
Automatic shutdown	35

B

Battery	
Battery information	46
Charge	47
Battery precautions	44
Handling	44
Storage	44

C

CE marking	50
Charging temperature	15, 46
Configuration menu	30

D

Dimensions	15
Disposal	45

F

FCC statement	51
FCC/IC labels	52
Functionality test	25

I

IC Statement	52
Inactivity timeout	35
IP code	15

L	
Load at start-up	43
Load select mode	36
Log out	27
Logout from Menu mode	40
Quick logout	27
M	
M245060	46
Maintenance	49
Menu mode	30
Enter Menu mode, no PIN code	31
N	
Number of channels	15
O	
Operating temperature	15
Operating time	15
P	
Power supply	15
R	
Radio frequency band	15
2.4 GHz	16
Frequency channels	16
Radio frequency output power	15
Radio mode	24
Register	28
Replace	32

S	
Safety Features	11
Safety levels	15
Select a Radio frequency	41
Show current radio frequency channel	34
Start a session	26
Start the transmitter	26
Stop button	11
Storage temperature	15
Battery	46
T	
Top LED	18-19
Transmitter back	18
Transmitter front views	17
W	
Warnings & restrictions	9
Installation and commission	9
Maintenance	10
Operation	10
WEEE directive	50
Weight	15

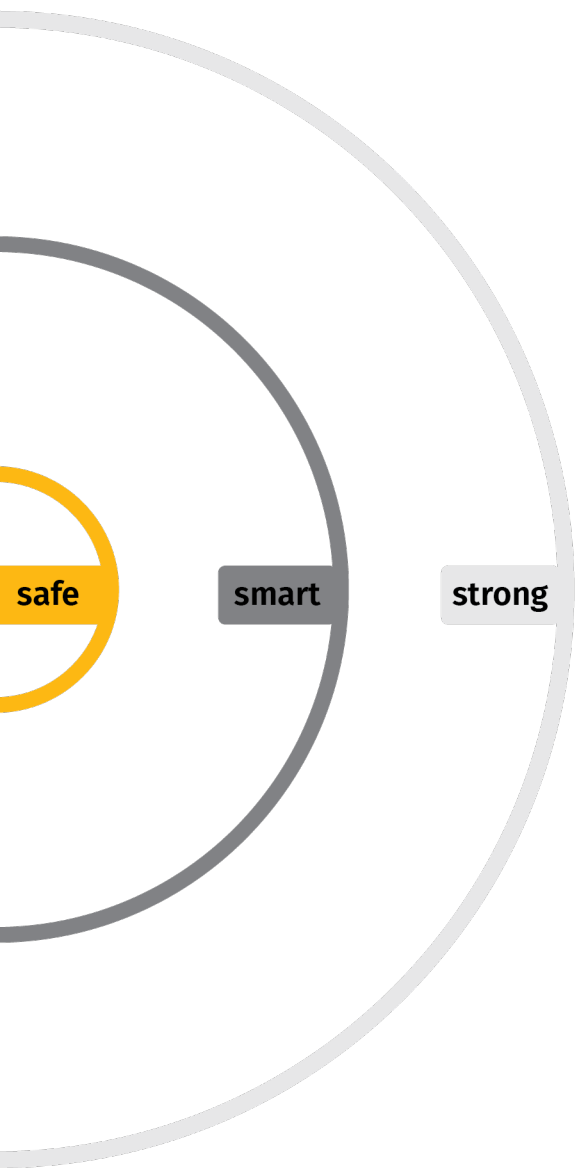

 **tele radio**[®]
wireless solutions

These Installation instructions are subject to change without prior notice.
Download the latest instructions from www.tele-radio.com.