

INSTALLATION INSTRUCTIONS

Transmitters:

T9-01, T9-11 T11-05, T11-15

safe

smart

strong

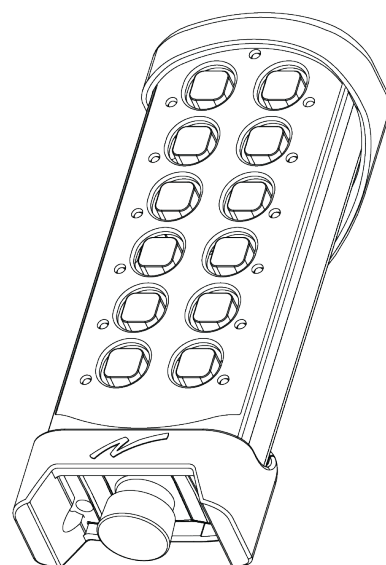
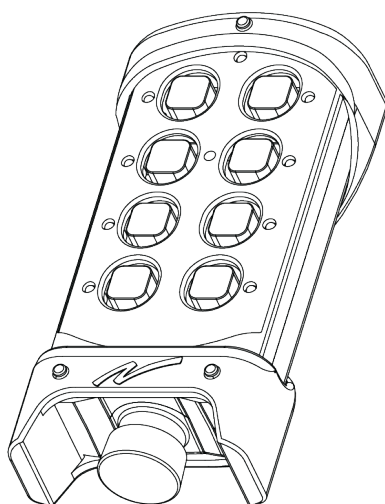

©Tele-Radio i Lysekil AB

August Barks gata 30A

SE-421 32 Västra Frölunda

Sweden

Phone: +46 (0)31 748 54 60

CHAPTER 1: INTRODUCTION	5
1.1 About this document	7
1.2 About Tiger TG2 systems	8
CHAPTER 2: SAFETY	9
2.1 Warnings & restrictions	9
2.2 Safety features	12
CHAPTER 3: FUNCTIONAL SAFETY	13
CHAPTER 4: TECHNICAL DATA	15
4.1 Transmitter specifications	15
4.2 Radio frequency band	17
CHAPTER 5: PRODUCT GENERAL DESCRIPTION	19
5.1 Transmitter front	19
5.2 Transmitter back	20
5.3 Top LED	21
CHAPTER 6: STATUS AND ERROR INDICATIONS	22
6.1 Top LED status indication	22
6.2 Error indications and error code messages	22
CHAPTER 7: OPERATION	25
7.1 General information	25
7.2 Start-up protection	25
7.3 Functionality test	26
7.4 Start a session (no PIN code)	27
7.5 Start a session (PIN code required)	29
7.6 Log the transmitter out from a receiver	31
7.7 Switch the transmitter off	31
CHAPTER 8: CONFIGURATION MENU	32
8.1 Menu mode and standard settings	32
8.2 Enter Menu mode	33
8.3 Show current radio frequency channel	34
8.4 Select a radio frequency channel	35
8.5 Register a transmitter in a receiver	37
8.6 Logout from Menu mode	42
8.7 Erase	43
8.8 Replace a transmitter	44

8.9 Set the radio inactivity timeout (automatic shutdown)	46
8.10 Load select mode	47
CHAPTER 9: BATTERY	52
9.1 Battery precautions	52
9.2 Battery information	54
CHAPTER 10: FOILS	58
10.1 Affix a foil to the transmitter	58
CHAPTER 11: WARRANTY, SERVICE, REPAIRS, AND MAINTENANCE	59
CHAPTER 12: REGULATORY INFORMATION	60
12.1 Europe	60
12.2 North America	61
12.3 Brazil	64
ANNEX A: GLOSSARY	65
ANNEX B: INDEX	66

CHAPTER 1: INTRODUCTION

Thank you for purchasing a Tele Radio product



READ ALL INSTRUCTIONS AND WARNINGS CAREFULLY BEFORE MOUNTING, INSTALLING, CONFIGURING AND OPERATING THE PRODUCTS.

These Installation instructions have been published by Tele Radio and are not subject to any guarantees. The Installation instructions may be withdrawn or revised by Tele Radio at any time and without further notice. Corrections and updates will be added to the latest version of the manual. Always download the Installation instructions from our website, www.tele-radio.com, for the latest available version. Keep the safety instructions for future reference.

IMPORTANT! These instructions are intended for installers and authorized service and distribution centers. The instructions containing information about the installation and configuration of the radio remote control unit on the machine are NOT intended to be passed on to the end user. Only information that is needed to operate the machine correctly by radio remote control may be passed on to the end user.

Tele Radio remote controls are often built into wider applications. This documentation is not intended to replace the determination of suitability or reliability of the product for specific user applications and should not be used for this purpose. It is the responsibility of any such users or integrators to perform the appropriate and complete risk analysis, evaluation and testing of the products with respect to the relevant specific application or use. Tele Radio shall not be responsible or liable for misuse of the information contained herein.

Always refer to the applicable local regulations for installation and safety requirements relating to cranes, hoists, material handling applications, lifting equipment, industrial machinery, and/or mobile hydraulic applications using Tele Radio products, e.g.:

- applicable local and industrial standards and requirements,
- applicable occupational health and safety regulations,
- applicable safety rules and procedures for the factory where the equipment is being used,
- user and safety manuals or instructions of the manufacturer of the equipment where Tele Radio remote control systems are installed.

Tele Radio Installation instructions do not include or address the specific instructions and safety warnings of the end product manufacturer.

For battery precautions, see "9.1 Battery precautions".

Tele Radio products are covered by a warranty against material, construction, or manufacturing faults. See "Chapter 11: Warranty, service, repairs, and maintenance".

1.1 About this document

Before installing or operating the product, read the corresponding documentation carefully.

Tele Radio's product range is composed of transmitters, receivers, and accessories intended for use together as a system.

These Installation instructions cover general safety issues, main technical specifications, standard installation, configuration and operating instructions, general troubleshooting and battery information. Images shown in this document are for illustrative purposes only.

Please report any error or omission in this document, as well as any improvement or amendment suggestion to td@tele-radio.com.

1.1.1 COPYRIGHT

Information in this document is subject to change without notice. No part of this publication may be reproduced, stored in a retrieval system, or transmitted in any form or by any means, electronic, photographic, mechanical (including photocopying), recording or otherwise for any purpose other than the purchaser's personal use without the written permission of Tele Radio.

1.1.2 TERM AND SYMBOL DEFINITIONS

The capitalized terms and symbol used herein shall have the following meaning:

- **WARNING:** indicates a hazardous situation which, if not avoided, could result in death or serious injury.
- **CAUTION:** indicates a hazardous situation which, if not avoided, will result in minor or moderate injury.
- **IMPORTANT:** is used for information that requires special consideration.
- **NOTE:** is used to address practices not related to physical injury.



This symbol is used to call attention to safety messages that would be assigned the signal words "WARNING" or "CAUTION".

1.2 About Tiger TG2 systems

The Tiger TG2 product range is composed of transmitters and receivers intended for use together as a system in complex lifting applications such as cranes, OHT cranes and electric hoists or mobile applications.

1.2.1 ABOUT T9/T11 TRANSMITTERS

T9/T11 transmitters have simplex communication with support for duplex.

T9/T11 transmitters are compatible with all R4, R9 and R10 receivers within the same frequency range.

Overview of the available models

Model	Step buttons transmitters Number of buttons				Display	Available frequencies	
	6	8	10	12		433 MHz	915 MHz
T9-01		●			-	●	
T9-11		●			-		●
T11-05				●	-	●	
T11-15				●	-		●

● Standard - Not available

CHAPTER 2: SAFETY

2.1 Warnings & restrictions



Carefully read through the following safety instructions before proceeding with the installation, configuration, operation, or maintenance of the product. Failure to follow these warnings could result in death or serious injury.

This product must not be operated without having read and understood the Installation instructions and having received the appropriate training. The purchaser of this product has been instructed how to handle the system safely. The following information is intended for use as a complement to applicable local regulations and standards.

IMPORTANT! Tele Radio remote controls are often built into wider applications.

These systems should be equipped with:

- a wired emergency stop where necessary
- a brake
- an audible or visual warning signal

2.1.1 INSTALLATION AND COMMISSIONING

IMPORTANT! Only licensed or qualified personnel should be permitted to install the product.



This radio system must not be used in areas where there is a risk of explosion.



Always switch off all electrical power from the equipment before installation procedure.



To utilize the safety features of the system, use the stop relays in the safety circuitry of the object/ equipment to be controlled.



When the equipment controlled by the receiver's standard relays is connected via the stop relays, make sure that the maximum current through the stop relays is still within the specifications. Contact your representative for assistance.



RISK OF UNINTENDED EQUIPMENT OPERATION

Only transmitters that are intended for use should be registered in the receiver.

Failure to follow these instructions could result in death, serious injury, or equipment damage.

2.1.2 OPERATION



This equipment is not suitable for use in locations where children are likely to be present.



Only qualified personnel should be permitted to access the transmitter and operate the equipment.



- **Make sure that the user satisfies the age requirements in your country for operating the equipment.**
- **Make sure that the user is not under the influence of drugs, alcohol and medications.**
- **Make sure that the user knows and follows operating and maintenance instructions as well as all applicable safety procedures and requirements.**

The user should:



- **Always test the transmitter stop button before operating it. This test should be done on each shift, without a load. See "2.2.1 Stop button".**
- **Never use a transmitter if the stop button is mechanically damaged. Contact your supervisor or representative for service immediately.**
- **Never leave the transmitter unattended.**
- **Always switch the transmitter off when not in use. Store in a safe place.**
- **Keep a clear view of the work area at all times.**

2.1.3 MAINTENANCE



Before maintenance intervention on any remote controlled equipments:

- **always remove all electrical power from the equipment.**
 - **always follow lockout procedures.**
-
- Keep the safety information for future reference. Always download the Installation instructions from our website, www.tele-radio.com, for the latest available version.
 - If error messages are shown, it is very important to find out what caused them. Contact your representative for help.
 - The functionality of the stop button should be tested at least after every 200 hours' use (see "2.2.1 Stop button").
 - If the stop button is mechanically damaged, do not use the transmitter. Contact your supervisor or representative for service immediately.
 - Keep the product in a clean, dry place.
 - Keep contacts and antennas clean.
 - Wipe off dust using a clean, slightly damp cloth.
 - Never use cleaning solutions.
 - Check the encapsulation, foils and cable for damages. If the encapsulation or foil is damaged, moisture can cause serious damage to the electronics.

2.2 Safety features

2.2.1 STOP BUTTON

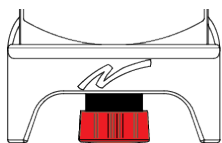

Tele Radio transmitters are equipped with a stop button.

When the **Stop** button is pressed, the stop relays on the receiver deactivate.

IMPORTANT! The Stop button should always be tested before operating the transmitter. This test should be done on each shift, without a load.

To test the stop button:

1. Press the **Stop** button.
2. Twist and release the **Stop** button.

CHAPTER 3: FUNCTIONAL SAFETY

NOTE: The information in this section applies only to the products operating in the 433 MHz and 915 MHz radio frequency ranges.

433 MHz	915 MHz
T9-01, T11-11	T9-05, T11-15

Safety functions

STOP FUNCTION

The safety-related stop function in the radio system complies with EN 61508 SIL3 and EN ISO 13849 PL_e. The stop relays on the receiver unit are controlled by the stop button on the transmitter unit. When the stop button is pressed, the stop relays interrupt the power to the safety-related application. The complete end user system, including the radio system, enters a safe state. The maximum response time for the stop function is 500 ms.

Installation

The two stop relays on the receiver unit shall be correctly installed to the end-user system requirements.

NOTE: The safety level of the stop function on the complete end-user system depends on other subsystem(s) and needs to be calculated by the manufacturer of the complete system.

Measures for probability of hardware failures

Transmitter stop function	
Probability of dangerous failure per hour	PFH _d = 8.5 FITs (=λ _{du})
Fraction of total failure rate with dangerous and detected consequence	λ _{dd} = 357 FITs
Diagnostic coverage	DC = 98.3 %
Safe failure fraction	SFF = 99.1 %
Common cause failure	0 FIT
Level of hardware fault tolerance	HFT = 1
Proof test interval	10 years
Diagnostic test interval	Continuous

Receiver stop function	
Probability of dangerous failure per hour	PFHd = 30.1 FITs (=λdu)
Fraction of total failure rate with dangerous and detected consequence	λdd = 685.0 FITs
Diagnostic coverage	DC = 96.9 %
Safe failure fraction	SFF = 98.7 %
Common cause failure	8.0 FIT
Level of hardware fault tolerance	HFT = 1
Proof test interval	10 years
Diagnostic test interval	Continuous

CHAPTER 4: TECHNICAL DATA

4.1 Transmitter specifications

	T9-01	T9-11	T11-05	T11-15
Number of buttons	8 x 2-step buttons		12 x 2-step buttons	
I/O switch	Yes		No	
Power supply	Internal, rechargeable lithium-ion battery		Replaceable, rechargeable lithium-ion battery	
Radio communication	Simplex (default), support for duplex			
Max. number of registered receivers	6		10	
Max. number of PIN codes	6			
Radio frequency band	433.075–434.775 MHz	903.0125–926.9875 MHz	433.075–434.775 MHz	903.0125–926.9875 MHz
Frequency management	2FSK modulation (Frequency-shift keying)	2FSK modulation (Frequency-shift keying) and frequency-hopping spread spectrum (FHSS)	2FSK modulation (Frequency-shift keying)	2FSK modulation (Frequency-shift keying) and frequency-hopping spread spectrum (FHSS)
Number of channels	69 (channel 1–69)	–	69 (channel 1–69)	–
Number of frequency banks	–	15 (bank 1–15)	–	15 (bank 1–15)
Radio frequency output power	EIRP ¹ : < 10 dBm (10 mW)	EIRP: < 0 dBm (1 mW)	EIRP: < 10 dBm (10 mW)	EIRP: < 0 dBm (1 mW)
Operating time (with continuous usage)	Approximately 24 h			
IP code	IP66		IP65	

¹Equivalent isotropic radiated power

	T9-01	T9-11	T11-05	T11-15
Operating temperature	-20...+55 °C / -4...+130 °F			
Charging temperature	+10...+35 °C / +50...+95 °F			
Safety levels	EN 61508 SIL3 and EN ISO 13849 PLe (Stop function, see "Chapter 3: Functional safety")			
Dimensions (LxWxH)	160 x 76 x 37 mm / 6.3 x 3 x 1.4 in		210 x 76 x 37 mm / 8.2 x 3 x 1.4 in	
Weight	295 g / 0.6 lbs		400 g / 0.9 lbs	

4.2 Radio frequency band

4.2.1 433 MHz

For radio systems operating on frequency band 433 MHz, the frequency band is divided into 69 channels (channel 1-69). Once the channel has been selected on the transmitter, the receiver will automatically detect and switch to the same channel.

Channel	Frequency (MHz)	Channel	Frequency (MHz)	Channel	Frequency (MHz)
01	433.075	26	433.700	51	434.325
02	433.100	27	433.725	52	434.350
03	433.125	28	433.750	53	434.375
04	433.150	29	433.775	54	434.400
05	433.175	30	433.800	55	434.425
06	433.200	31	433.825	56	434.450
07	433.225	32	433.850	57	434.475
08	433.250	33	433.875	58	434.500
09	433.275	34	433.900	59	434.525
10	433.300	35	433.925	60	434.550
11	433.325	36	433.950	61	434.575
12	433.350	37	433.975	62	434.600
13	433.375	38	434.000	63	434.625
14	433.400	39	434.025	64	434.650
15	433.425	40	434.050	65	434.675
16	433.450	41	434.075	66	434.700
17	433.475	42	434.100	67	434.725
18	433.500	43	434.125	68	434.750
19	433.525	44	434.150	69	434.775
20	433.550	45	434.175		
21	433.575	46	434.200		
22	433.600	47	434.225		
23	433.625	48	434.250		
24	433.650	49	434.275		
25	433.675	50	434.300		

4.2.2 915 MHz

Radio systems operating on frequency band 915 MHz use frequency-hopping spread spectrum (FHSS) to communicate. The frequency band is divided into 15 frequency banks (1-15). Frequency bank 8 is selected by default.

To establish a radio link between the receiver and the transmitter, both units must be configured to use the same frequency bank. Contact your representative for assistance.

CHAPTER 5: PRODUCT GENERAL DESCRIPTION

The pictures shown in this chapter are for illustrative purposes only.

5.1 Transmitter front

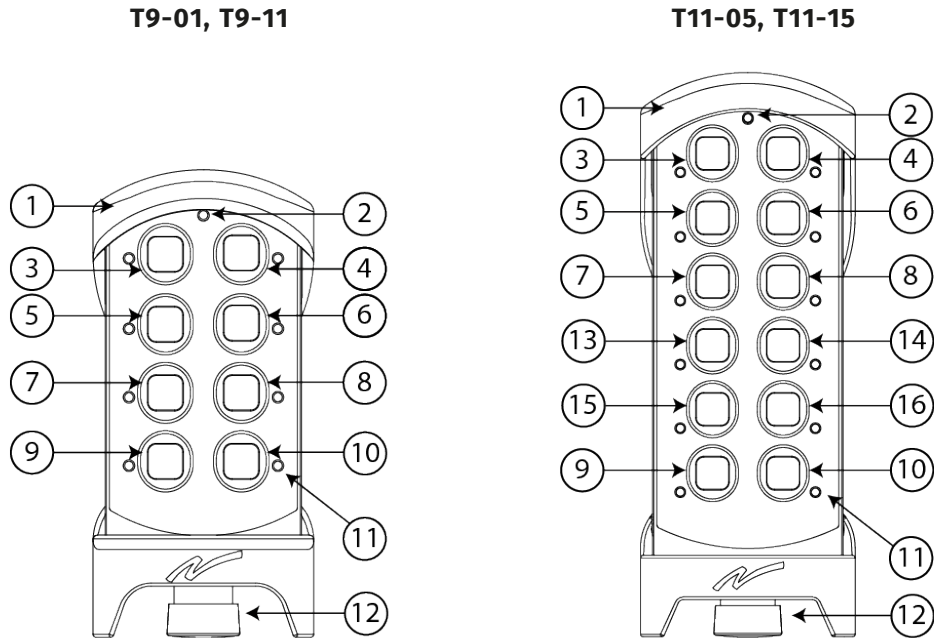

- | | | | |
|-----------------|-------------|---|---------------|
| 1. Rubber cover | 5. Button 3 | 9. Left Start button (SL) ¹ | 13. Button 7 |
| 2. Top LED | 6. Button 4 | 10. Right Start button (SR) ² | 14. Button 8 |
| 3. Button 1 | 7. Button 5 | 11. Button LEDs | 15. Button 9 |
| 4. Button 2 | 8. Button 6 | 12. Stop button | 16. Button 10 |

5.1.1 SHIFT BUTTON

In some cases, the **right Start** button is used as a shift button to access some menus and/or channels.

To activate the shift function, press the shift button and keep it pressed. Press the button corresponding to the desired channel/ menu. Release it, then release the shift button.

¹T9: button 7; T11: button 11.

²T9: button 8; T11: button 12.

5.2 Transmitter back

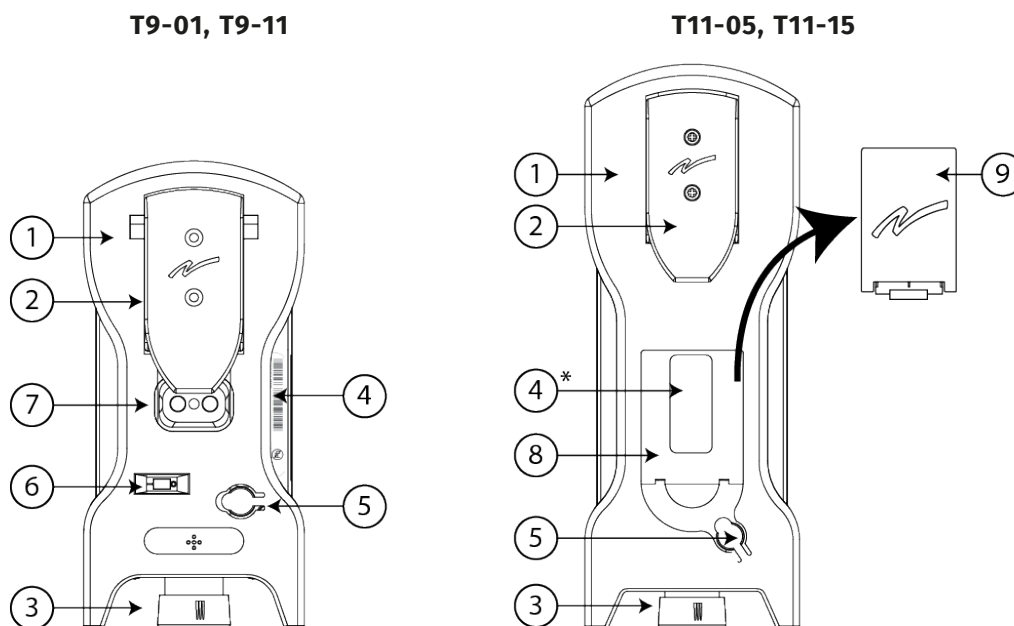

- | | | |
|-----------------------|-------------------------------|--|
| 1. Rubber cover | 4. Product label ¹ | 7. Charger contacts for Tele Radio holders |
| 2. Clip | 5. Battery charger socket | 8. Battery compartment |
| 3. Stop button | 6. I/O switch | 9. Replaceable battery |

5.2.1 I/O SWITCH (T9 MODELS ONLY)

The I/O switch on the back of the transmitter interrupts the power supply from the battery. When in the O/off position, the transmitter cannot be started unless the charger plug is connected.

IMPORTANT! When the transmitter is to be transported by air, the I/O switch must be in the O/off position.

NOTE: The I/O switch should not be used as an on/off button for the transmitter. To start and stop the transmitter, use the **Stop** button.

¹*On T11 models, the product label is placed inside the battery compartment.

5.3 Top LED

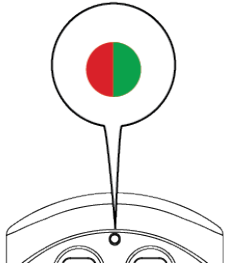

The transmitter is equipped with one bi-color LED (top LED) for battery indication and radio link information. For more details, see "Chapter 6: Status and error indications"

CHAPTER 6: STATUS AND ERROR INDICATIONS

6.1 Top LED status indication

The top LED lights or flashes green when the battery capacity is good and red when the battery capacity is poor. When the top LED lights/flashes red, battery should be charged or changed at the next convenient opportunity (see "9.2.2 Charge the battery").

6.2 Error indications and error code messages

Each error is identified by a code indicated by a LED combination including the Top LED (LED 0), button LEDs 1–6 and SL and SR LEDs.

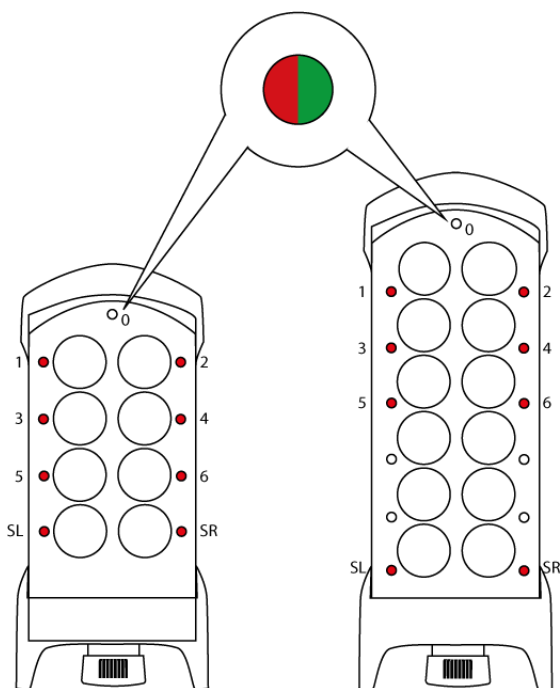

●: LED is lit (red). ○: LED is off

⦿: LED is blinking green/red.

LED0 green/red	LED1 red	LED2 red	LED3 red	LED4 red	LED5 red	LED6 red	LED- SL red	LED- SR red	Indicates
⦿	●	○	○	○	○	○	○	○	No correct software ID read from CPU2

LED0 green/red	LED1 red	LED2 red	LED3 red	LED4 red	LED5 red	LED6 red	LED- SL red	LED- SR red	Indicates
◉	○	●	○	○	○	○	○	○	Safe buttons has been pressed during start-up or stop button test is required
◉	○	○	●	○	○	○	○	○	CPU2 start-up test has failed
◉	○	○	○	●	○	○	○	○	Stop button hardware failure
◉	○	○	○	○	●	○	○	○	No production data received from the radio module ¹
◉	○	○	○	○	○	●	○	○	No production data received from CPU2
◉	●	○	○	○	○	○	●	○	Incompatible HW version
◉	○	●	○	○	○	○	●	○	Initialization of API settings has failed ²
◉	○	○	●	○	○	○	●	○	Unidentified radio ³
◉	○	○	○	●	○	○	●	○	Incompatible radio module (frequency)
◉	●	○	○	○	○	○	○	●	CPU1 has tried to send an incorrect radio packet
●	●	○	○	○	○	○	○	○	General timeout, operation failed
●	○	●	○	○	○	○	○	○	Login failed, an other TX is already logged in
●	○	○	●	○	○	○	○	○	Incompatible xApp software between TX/RX

¹Possibly disconnected.

²Possibly bad flash memory

³Possibly disconnected

LED0 green/red	LED1 red	LED2 red	LED3 red	LED4 red	LED5 red	LED6 red	LED- SL red	LED- SR red	Indicates
●	○	○	○	●	○	○	○	○	Incompatible config-ID between TX/RX
●	○	○	○	○	●	○	○	○	Unexpected response from RX (general error during login/register, etc.)
●	○	○	○	○	○	●	○	○	Incompatible RX/TX setting (how many unit can be registered)
○	●	○	○	○	○	○	●	●	LML not implemented
○	○	●	○	○	○	○	●	●	LML stack overflow
○	○	○	●	○	○	○	●	●	LML stack underflow
○	○	○	○	●	○	○	●	●	LML too many instructions
○	○	○	○	○	●	○	●	●	LML bad call ID
○	○	○	○	○	○	●	●	●	LML general error
○	●	●	○	○	○	○	●	●	Missing or bad binDat
○	●	○	●	○	○	○	●	●	No binDat ID
○	●	○	○	●	○	○	●	●	Bad SW ID
○	●	○	○	○	●	○	●	●	Bad SW version
○	●	○	○	○	○	○	●	●	Bad cclml version

CHAPTER 7: OPERATION

7.1 General information

To control a receiver, the transmitter must be registered and logged in to the receiver. If another transmitter is already logged in to the receiver, it must be logged out before a different transmitter can be logged in.

If no transmitter is logged in to the receiver, proceed with the login procedure before using the system. Once a transmitter has been logged in, it will remain logged in until it is manually logged out.

More than one transmitter can be registered in the receiver, but only one transmitter can be logged in at a time.

7.2 Start-up protection

PIN codes can be activated to prevent unauthorized personnel from operating the transmitter.

7.2.1 ENABLE START-UP PROTECTION

To enable PIN codes for transmitter start-up protection, contact your representative for assistance. All PIN code settings require assistance.

7.3 Functionality test

NOTE: This list is intended for use as a support for the manufacturer of the equipment where Tele Radio remote control systems are installed.

Before operating the radio system, follow the procedure below.

IMPORTANT! This test should be performed at each shift, without a load, and should include but not be limited to the following steps

- Make sure that the controlled object can not cause any harm in the event of unexpected movement.
- Always follow local safety rules and start the equipment according to the corresponding instructions.
- Make sure that the transmitter can control the receiver by testing all functions.
- Make sure that the functions respond as expected.
- Make sure that all movements are as planned.
- Make sure that the stop button works correctly.
- Make sure that the stop function works correctly.
- Make sure the system stops when the battery is removed from the transmitter.

7.4 Start a session (no PIN code)

To be able to control a receiver with the transmitter, the transmitter must be registered in the receiver. If no receiver is registered, the red LED next to the **right Start** button will flash after the **Stop** button has been pulled out.



When not in use, transmitters must be switched off and stored in a secure storage space.



Do not use the system if the stop button is damaged or if it does not stop the equipment. Doing so could result in serious injury or death.

NOTE: If no action is taken within 3 minutes after the **Stop** button has been released, the transmitter will turn off. Press the **Stop** button before making a new attempt to start the transmitter.

NOTE: The last accessed receiver(s) will automatically be selected the next time the transmitter is started.

1. Make sure that the **Stop** button is pressed.
2. Twist and release the **Stop** button.
The top LED lights.
 The receiver(s) selected in the last session are indicated by the corresponding red lit LED. Go to step 4 to log in to the previously selected receiver, go to next step to select another receiver.
 If no receiver is selected, the red LEDs for all available receivers will flash.
3. Press the button(s) corresponding to the receiver(s) to operate.
The respective red LEDs stop flashing and remain lit. Both start button LEDs flash.
 To cancel, press the same button again. The corresponding red LED starts flashing. Both start button LEDs go out.
4. Press and hold both **Start** buttons simultaneously.
The buzzer emits a beep.
5. Release both **Start** buttons.
The buzzer stops beeping. The top LED flashes.

When a radio link has been established, the top LED stops flashing and remains lit, the selected receivers red LEDs go out and the stop relays activate.

6. Proceed with the functional test (see "7.3 Functionality test").

If no radio link is established within 25 seconds, the transmitter will turn off. Go back to step 1 and try again.

7.5 Start a session (PIN code required)

To be able to control a receiver with the transmitter, the transmitter must be registered in the receiver. If no receiver is registered, the red LED next to the **right Start** button will flash after the **Stop** button has been pulled out.



When not in use, transmitters must be switched off and stored in a secure storage space.



Do not use the system if the stop button is damaged or if it does not stop the equipment. Doing so could result in serious injury or death.

NOTE: If no action is taken within 3 minutes after the **Stop** button has been released, the transmitter will turn off. Press the **Stop** button before making a new attempt to start the transmitter.

NOTE: The last accessed receiver(s) will automatically be selected the next time the transmitter is started.

1. Make sure that the **Stop** button is pressed.
2. Twist and release the **Stop** button.
The top LED lights.
 If a PIN code is required, it will be indicated as follow.
T9: LEDs 1–6 flash red; **T11:** LEDs 1–10 flash red
3. Enter the PIN code (4 digits). Use the buttons according to the following table.

Digit	T9-01, T9-11	T11-05, T11-15
1–6	Buttons 1–6	
7	Press and hold button 8 (shift) + press button 1	Button 7
8	Press and hold button 8 (shift) + press button 2	Button 8
9	Press and hold button 8 (shift) + press button 3	Button 9
0	Press and hold button 8 (shift) + press button 4	Button 10

The receiver(s) selected in the last session are indicated by the corresponding red lit LED.

Go to step 5 to log in to the previously selected receiver, go to next step to select another receiver.

If no receiver is selected, the red LEDs for all available receivers will flash.

4. Press the button(s) corresponding to the receiver(s) to operate.
The respective red LEDs stop flashing and remain lit. Both start button LEDs flash.
To cancel, press the same button again.
The corresponding red LED starts flashing. Both start button LEDs go out.
5. Press and hold both **Start** buttons simultaneously.
The buzzer emits a beep.
6. Release both **Start** buttons.
The buzzer stops beeping. The top LED flashes. .
When a radio link has been established, the top LED stops flashing and remains lit, the selected receivers red LEDs go out and the stop relays activate.
7. Proceed with the functional test (see "7.3 Functionality test").

If no radio link is established within 25 seconds, the transmitter will turn off. Go back to step 1 and try again.

7.6 Log the transmitter out from a receiver

A transmitter already logged in to the receiver has to be logged out before any other transmitter can be logged in. If a transmitter has been lost or seriously damaged, use the replace procedure on the transmitter.

NOTE: Logout can only be performed when the transmitter is on and a radio link with one or more receivers has been established. The receiver must be powered-up for the logout procedure to be successful.

NOTE: The logout procedure will log the transmitter out from all receivers that are part of the radio session.

7.6.1 QUICK LOGOUT

1. Make sure that the transmitter is started. If not, twist and release the **Stop** button.
2. Press and hold the **left Start** button.¹
3. Press the **Stop** button.
The top LED lights (red).
4. Release the **left Start** button.
The transmitter takes approximately 3 seconds to logout. The transmitter turns off.

It is also possible to log out from the **Menu mode**, see "8.6 Logout from Menu mode".

7.7 Switch the transmitter off

NOTE: When the transmitter is switched off, it remains logged in to the receiver(s). To logout, see "7.6 Log the transmitter out from a receiver"

When the transmitter is active and the stop button is pressed, all relays on the receiver deactivate.

1. Press the **Stop** button.
The transmitter turns off. All relays on the receiver deactivate.

¹**T9:** button 7; **T11:** button 11.

CHAPTER 8: CONFIGURATION MENU

8.1 Menu mode and standard settings

The **Menu mode** allows for certain settings to be set directly from the transmitter. Once in **Menu mode**, the following menus will be available.

In some cases, the **right Start** button¹ is used as a shift button to access some menus and/or channels.

To activate the shift function, press the shift button and keep it pressed. Press the button corresponding to the desired menu/channel number. Release it, then release the shift button.

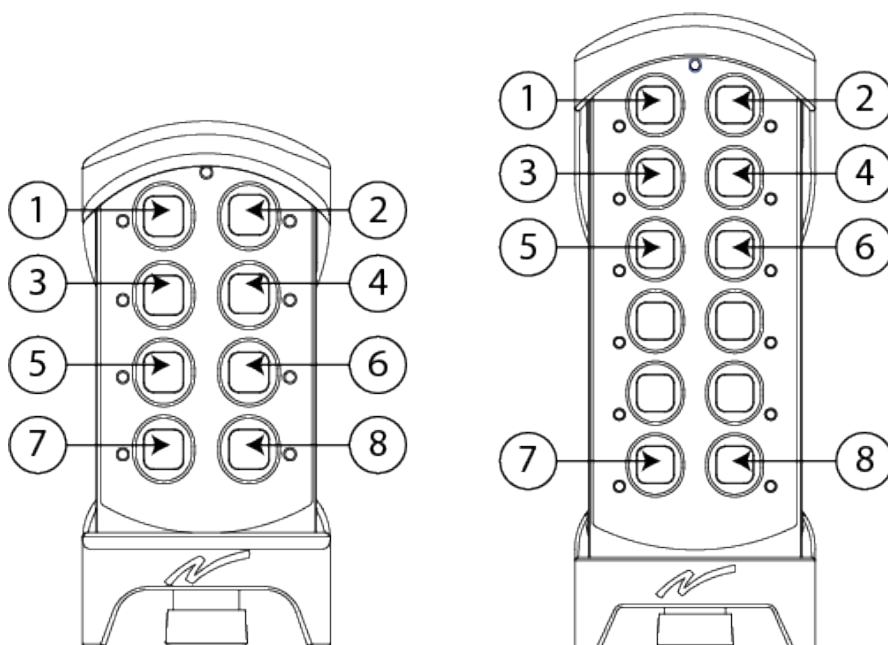

	Menu	Decription
1	Register	Register the transmitter in a receiver
2	Erase	Erase the transmitter from a receiver
3	Replace	Replace a lost or damaged transmitter
4	Show channel	Show the channel/bank currently used
5	Automatic shutdown	Select the radio inactivity timeout
6	Load select mode	Select a load option (0-7)
7	Logout	Log out the transmitter from a receiver
8+4	Switch channel	Select the channel/bank to use

¹T9: button 8; T11: button 12.

8.2 Enter Menu mode

The transmitter settings are configured in the **Menu mode**.

1. Make sure that the **Stop** button is pressed.
2. Twist and release the **Stop** button.
The top LED lights.
3. Press and hold the **right Start** button.¹
4. Press the **Stop** button.
5. Release the **right Start** button.
The top LED flashes and all button LEDs representing a menu flash.
6. Select a menu by pressing the buttons according to the following table.

Menu	T9-01, T9-11	T11-05, T11-15
Register	Button 1	
Erase	Button 2	
Replace	Button 3	
Show channel	Button 4	
Automatic shutdown	Button 5	
Load select mode	Button 6	
Logout	Button 7	Button 11
Switch channel	Press and hold button 8 (shift) + press button 4	Press and hold button 12 (shift) + press button 4

¹T9: button 8; T11: button 12.

8.3 Show current radio frequency channel

Channels are indicated by LEDs 1 and 2, which represent the first and second digit of the channel respectively.

1. Make sure that the **Stop** button is pressed.
2. Twist and release the **Stop** button.
The top LED lights.
3. Press and hold the **right Start** button.¹
4. Press the **Stop** button.
5. Release the **right Start** button.
The top LED flashes. All menu LEDs flash.
6. Press button 4 to enter the [Show channel] menu.
LED 1 flashes a number of times corresponding to the 1st digit.
LED 2 flashes a number of times corresponding to the 2nd digit.²

¹T9: button 8; T11: button 12.

²Example: For channel 54, LED 1 will flash 5 times and LED 2 will flash 4 times. For channel 9, LED 2 will flash 9 times.

8.4 Select a radio frequency channel

For radio systems operating on frequency band 433 MHz, it is possible to switch channels. To switch frequency bank on radio systems operating on frequency band 915 MHz, contact your representative for assistance.

NOTE: For available channels or frequency banks, see "4.2 Radio frequency band".

1. Make sure that the **Stop** button is pressed.
2. Twist and release the **Stop** button.
The top LED lights.
3. Press and hold the **right Start** button.¹
4. Press the **Stop** button.
5. Release the **right Start** button.
The top LED flashes. All menu LEDs flash.
6. Press and hold the **right Start** button.
7. Press button 4.
8. Release button 4.
9. Release the **right Start** button. .
The top LED flashes. The transmitter enters the [Switch channel] menu.
10. Enter the first digit of the new channel by pressing the buttons according to the following table.

Digit	T9-01, T9-11	T11-05, T11-15
1–6	Buttons 1–6	
7	Press and hold button 8 (shift) + press button 1	Button 7
8	Press and hold button 8 (shift) + press button 2	Button 8
9	Press and hold button 8 (shift) + press button 3	Button 9

¹T9: button 8; T11: button 12.

Digit	T9-01, T9-11	T11-05, T11-15
0	Press and hold button 8 (shift) + press button 4	Button 10

LED 1 lights and the LED next to the left start button flashes (red).

11. Enter the second digit, or for channels 1–9 press the **left Start** button¹ directly after entering the first digit.
*After entering the second digit, the top LED stops flashing and remains lit.
The transmitter turns off.*

To check that the channel has been properly changed, see "8.3 Show current radio frequency channel".

¹**T9**: button 7; **T11**: button 11.

8.5 Register a transmitter in a receiver

T9 transmitters can have up to 6 registered receivers (location 1–6), T11 transmitters up to 10 (location 1–10).

NOTE: The registration instructions require access to the receiver circuit board. Before starting the registration of a transmitter, prepare the receiver as follow:



Risk of electric shock. The receiver must only be opened by qualified installers. Make sure the power supply is switched off before opening the receiver.

1. Remove the front cover of the receiver. Use a screwdriver to remove the screws.
2. Power the receiver up.
The Power LED lights (yellow).
3. Proceed with the registration procedure for the corresponding receiver ([R4/R10](#) or [R9](#)).

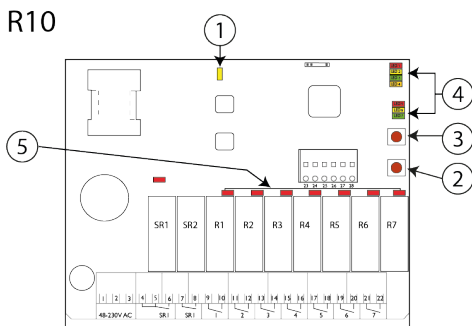
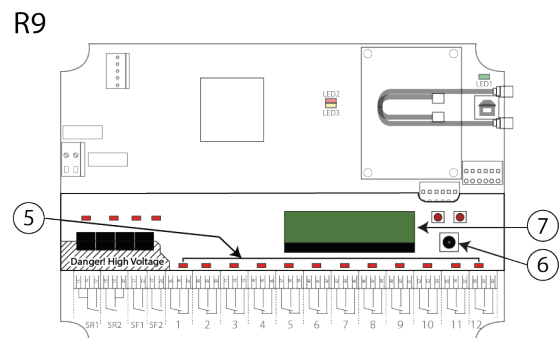
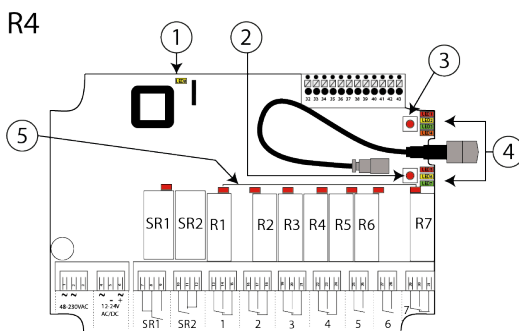

- | | | |
|---------------------------|-------------------------|------------------|
| 1. Power LED | 4. Function LEDs | 6. Mini joystick |
| 2. Select button | 5. Relay LEDs | 7. LCD display |
| 3. Function button | | |

8.5.1 REGISTER THE TRANSMITTER IN A RECEIVER WITHOUT DISPLAY (R4, R10)



RISK OF UNINTENDED EQUIPMENT OPERATION

Only transmitters that are intended for use should be registered in the receiver.

Failure to follow these instructions could result in death, serious injury, or equipment damage.



RISK OF UNINTENDED EQUIPMENT OPERATION

Do not perform this action when the receiver is in a session with another transmitter. The radio communication may be interrupted or broken.

Failure to follow these instructions could result in death, serious injury, or equipment damage.

NOTE: For the registration procedure to be successful, the receiver must be powered up.

1. Make sure that the **Stop** button is pressed.
2. Twist and release the **Stop** button.
The top LED lights.
3. Press and hold the **right Start** button.¹
4. Press the **Stop** button.
5. Release the **right Start** button.
The top LED flashes. All menu LEDs flash.
6. Press button 1 to enter the [Register] menu.
7. Press a button on the transmitter to select an empty location (**T9**: buttons 1–6; **T11**: buttons 1–10).²
Occupied locations are indicated by the corresponding red lit LED. When an available location has been selected the corresponding LED will flash.

¹**T9**: button 8; **T11**: button 12.

²Location 1 is selected by default.

8. Press the **left Start** button to confirm.¹
The LEDs next to both start buttons light.

ON THE RECEIVER

9. Press the top button (**Function** button)
Function LED 1 flashes (red). Red lit relay LEDs 1–7 show the number of transmitters already registered in the receiver².
10. Press the bottom button (**Select** button).
All relay LEDs light red. The receiver will remain in registration mode for 1 minute.
Once the receiver has found the transmitter, Function LED 1 and all the receiver relay LEDs will flash.
11. Press the bottom button (**Select** button) again.
Function LEDs 1–7 flash 3 times (multicolor). All relay LEDs go out. All function LEDs light for approximately 1 second.
The transmitter is now registered in the receiver.
The transmitter turns off.

If not successfully completed, the top LED lights red and the buzzer emits a beep. The transmitter turns off. Go back to step 1 and try again.

¹**T9**: button 7; **T11**: button 11.

²Example: LED1 = 1 registered TX, LED2 = 2 registered TX, etc.

8.5.2 REGISTER THE TRANSMITTER IN A RECEIVER WITH DISPLAY (R9)



RISK OF UNINTENDED EQUIPMENT OPERATION

Only transmitters that are intended for use should be registered in the receiver.

Failure to follow these instructions could result in death, serious injury, or equipment damage.



RISK OF UNINTENDED EQUIPMENT OPERATION

Do not perform this action when the receiver is in a session with another transmitter. The radio communication may be interrupted or broken.

Failure to follow these instructions could result in death, serious injury, or equipment damage.

NOTE: For the registration procedure to be successful, the receiver must be powered up.

1. Make sure that the **Stop** button is pressed.
2. Twist and release the **Stop** button.
The top LED lights.
3. Press and hold the **right Start** button.¹
4. Press the **Stop** button.
5. Release the **right Start** button.
The top LED flashes. All menu LEDs flash.
6. Press button 1 to enter the [Register] menu.
7. Press a button on the transmitter to select an empty location (**T9**: buttons 1–6; **T11**: buttons 1–10).²
Occupied locations are indicated by the corresponding red lit LED. When an available location has been selected the corresponding LED will flash.
8. Press the **left Start** button to confirm.³
The LEDs next to both start buttons light.

¹**T9**: button 8; **T11**: button 12.

²Location 1 is selected by default.

³**T9**: button 7; **T11**: button 11.

ON THE RECEIVER

9. Use the mini joystick to select `[Register TX]` in the receiver display menu.
10. Press the mini joystick to confirm.
11. Use the mini joystick to select `[Yes]`. Press to confirm and begin registration. The receiver will remain in registration mode until a transmitter has been registered or for up to 1 minute. Once the receiver has found the transmitter, the display will show `[Confirm TX] [TX ID:]`.
12. Press the mini joystick to confirm.
The receiver's display shows `[OK]`.
The transmitter is now registered in the receiver.
The transmitter turns off.

If not successfully completed, the top LED lights red and the buzzer emits a beep. The transmitter turns off. Go back to step 1 and try again.

8.6 Logout from Menu mode

This logout option is used mainly when the Quick logout button is being used by another function.

NOTE: Logout can only be performed when the transmitter is on and a radio link with one or more receivers has been established. The receiver must be powered-up for the logout procedure to be successful.

NOTE: The logout procedure will log the transmitter out from all receivers that are part of the radio session.

1. Make sure that the **Stop** button is pressed.
2. Twist and release the **Stop** button.
The top LED lights.
3. Press and hold the **right Start** button.¹
4. Press the **Stop** button.
5. Release the **right Start** button.
The top LED flashes. All menu LEDs flash.
6. Press the left **Start** button² to enter the [Logout] menu.
The LEDs corresponding to registered receivers flash.
7. Press the button corresponding to the receiver to be logged out from (**T9**: buttons 1–6; **T11**: buttons 1–10).
The corresponding LED stops flashing and remains lit.³
8. Press the **left Start** button to confirm.
If successfully completed, the top LED stops flashing and remains lit. The transmitter turns off.

If not successfully completed, the top LED lights red and the buzzer emits a beep. The transmitter turns off. Go back to step 1 and try again.

¹**T9**: button 8; **T11**: button 12.

²**T9**: button 7; **T11**: button 11.

³For ex. if the transmitter is registered in one receiver only and the chosen location was 1, press button 1. LED 1 stops flashing and remains lit.

8.7 Erase

This procedure will erase the transmitter from the selected receiver and vice versa.

NOTE: If a transmitter has been lost or seriously damaged, use the replace procedure on the transmitter.

NOTE: The receiver must be powered up for the Erase procedure to be successful.

1. Make sure that the **Stop** button is pressed.
2. Twist and release the **Stop** button.
The top LED lights.
3. Press and hold the **right Start** button.¹
4. Press the **Stop** button.
5. Release the **right Start** button.
The top LED flashes. All menu LEDs flash.
6. Press button 2 to enter the [Erase] menu.
*The LEDs corresponding to registered receivers flash.*²
7. Press the button corresponding to the receiver to be erased.
The corresponding LED stops flashing and remains lit.
8. Press the **left Start** button to confirm.³
If successfully completed, the top LED stops flashing and remains lit. The transmitter turns off.

If not successfully completed, the transmitter turns off. Go back to step 1 and try again.

¹**T9:** button 8; **T11:** button 12.

²During transmitter registration a location number has been affected to one or several receiver(s).

³**T9:** button 7; **T11:** button 11.

8.8 Replace a transmitter

It is possible to replace a registered transmitter with another transmitter of the same model. The procedure does not require to open the receiver housing but the receiver needs to be powered up and within transmission range. Use the transmitter that will replace the old transmitter to perform the following instructions.

If the transmitter being replaced is registered in more than one receiver, it will only be replaced in one receiver at a time. To replace a transmitter in more than one receiver, the replacement procedure must be completed for each receiver.



RISK OF UNINTENDED EQUIPMENT OPERATION

Do not perform this action when the receiver is in a session with another transmitter. The radio communication may be interrupted or broken. Failure to follow these instructions could result in death, serious injury, or equipment damage.

IMPORTANT! If the transmitter already has receivers registered, it is recommended to erase them all from the transmitter before starting the replacement. The receiver will automatically be stored in the same location as in the old transmitter. If this location is no longer available, the replacement will fail.

NOTE: The product label is located at the back of the transmitter. For more details, see "5.2 Transmitter back"

1. Make sure that the **Stop** button is pressed.
2. Twist and release the **Stop** button.
The top LED lights.
3. Press and hold the **right Start** button.¹
4. Press the **Stop** button.
5. Release the **right Start** button.
The top LED flashes. All menu LEDs flash.
6. Press button 3 to enter the [Replace] menu.

¹T9: button 8; T11: button 12.

The LEDs corresponding to registered receivers flash.¹

7. Enter the serial number (SN)² of the transmitter **to be replaced** (i.e. the old, lost or damaged transmitter). Press the buttons according to the following table.

Digit	T9-01, T9-11	T11-05, T11-15
1-6	Buttons 1-6	
7	Press and hold button 8 (shift) + press button 1	Button 7
8	Press and hold button 8 (shift) + press button 2	Button 8
9	Press and hold button 8 (shift) + press button 3	Button 9
0	Press and hold button 8 (shift) + press button 4	Button 10

Button LEDs (1-6) light after the corresponding digit has been entered.³

8. Press the **left Start** button to confirm.⁴
If successfully completed, the top LED stops flashing and remains lit. The transmitter turns off.

If not successfully completed within 25 s, the top LED lights red and the buzzer emits a beep. The transmitter turns off. Go back to step 1 and try again.

¹During transmitter registration a location number has been affected to one or several receiver(s).

²The product label is located at the back of the transmitter. For more details, see "5.2 Transmitter back"

³Example: LED 1 will light after the first digit of the SN number has been entered, then LED 2, etc.

⁴T9: button 7; T11: button 11.

8.9 Set the radio inactivity timeout (automatic shutdown)

Set the off delay (in seconds) before the transmitter automatically turns off. Automatic shutdown helps prolong battery capacity by automatically turning the transmitter off after a preset period of inactivity.

1. Make sure that the **Stop** button is pressed.
2. Twist and release the **Stop** button.
The top LED lights.
3. Press and hold the **right Start** button.¹
4. Press the **Stop** button.
5. Release the **right Start** button.
The top LED flashes. All menu LEDs flash.
6. Press button 5 to enter the [Automatic shutdown] menu.
The top LED flashes.
7. Select the automatic shutdown time by pressing a button according to the following table.

Automatic shutdown time	T9-01, T9-11	T11-05, T11-15
2 minutes	Button 1	
6 minutes	Button 2	
12 minutes	Button 3	
no automatic shutdown	Button 7	Button 11

If successfully completed, the top LED stops flashing and remains lit. The transmitter turns off.

If not successfully completed within 25 s, the top LED lights red and the buzzer emits a beep. The transmitter turns off. Go back to step 1 and try again.

¹T9: button 8; T11: button 12.

8.10 Load select mode

There are eight different **Load select** modes (0–7).

1. Make sure that the **Stop** button is pressed.
2. Twist and release the **Stop** button.
The top LED lights.
3. Press and hold the **right Start** button.¹
4. Press the **Stop** button.
5. Release the **right Start** button.
The top LED flashes. All menu LEDs flash.
6. Press button 6 to enter the [Load select] menu.
The top LED flashes.
7. Select the **Load select** by pressing a button according to the following table.

Load select mode	T9-01, T9-11	T11-05, T11-15
1	Button 1	
2	Button 2	
3	Button 3	
4	Button 4	
5	Button 5	
6	Button 6	
7	Press and hold button 8 (shift) + press button 1	Button 7
0	Button 7	Button 11

If successfully completed, the top LED stops flashing and remains lit. The transmitter turns off.

If not successfully completed within 25 s, the top LED lights red and the buzzer emits a beep. The transmitter turns off. Go back to step 1 and try again.

¹T9: button 8; T11: button 12.

8.10.1 LOAD SELECT MODE 0

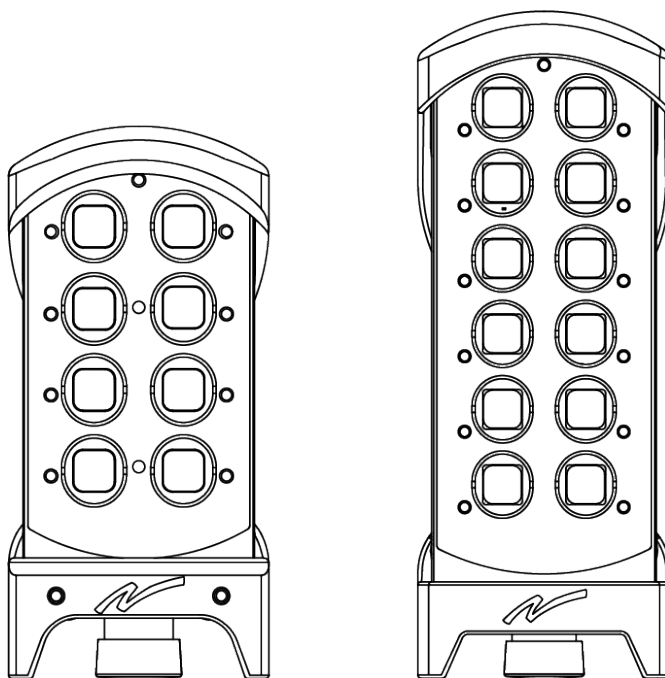

8.10.2 LOAD SELECT MODE 1

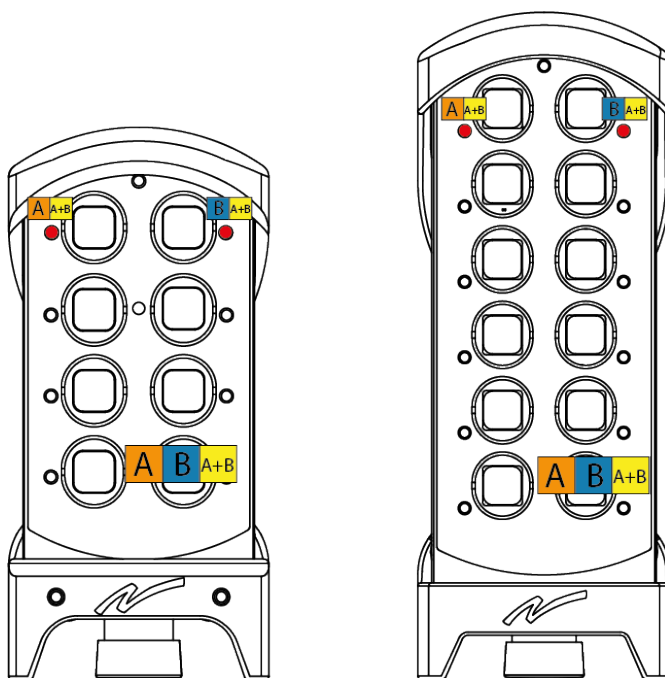

8.10.3 LOAD SELECT MODE 2

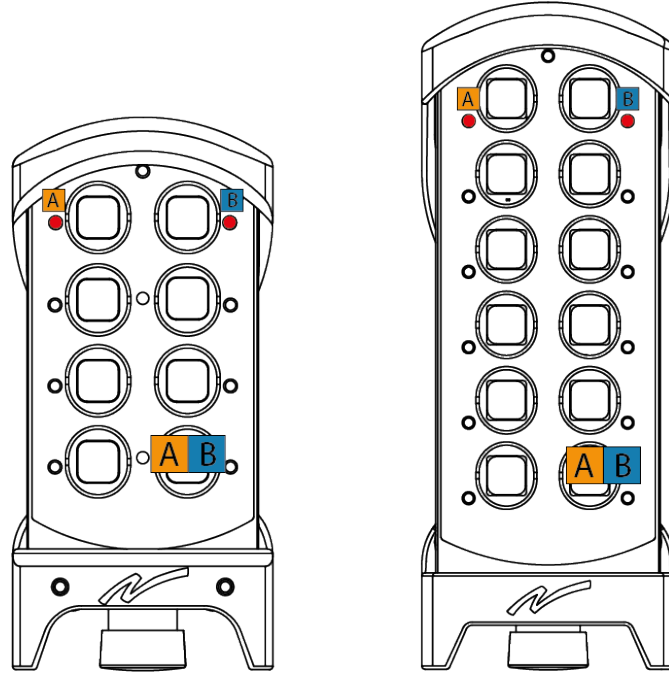

8.10.4 LOAD SELECT MODE 3

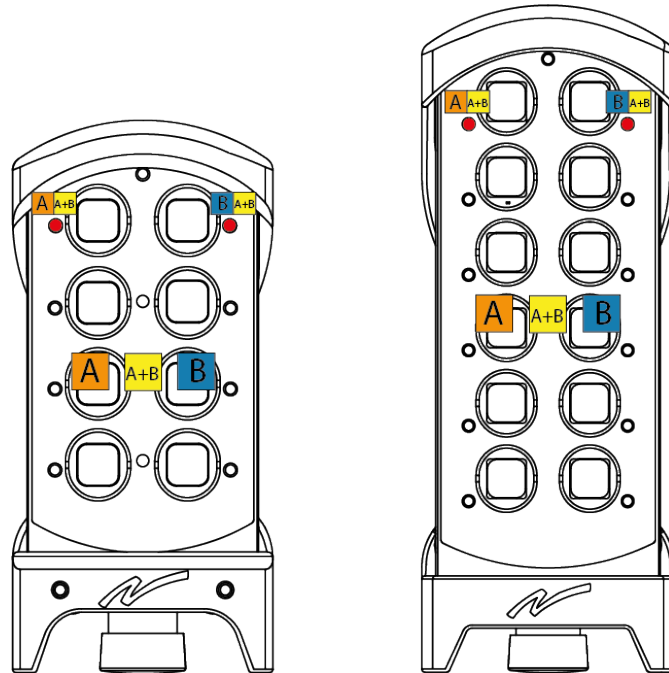

8.10.5 LOAD SELECT MODE 4

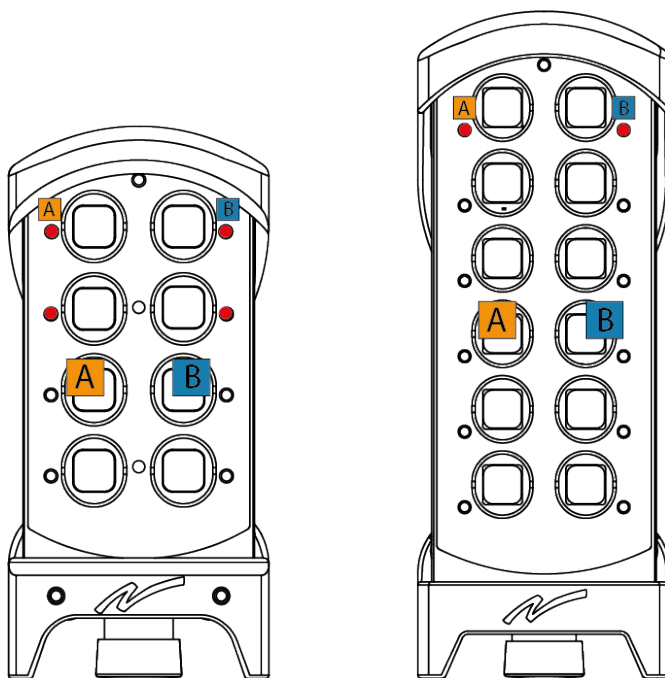

8.10.6 LOAD SELECT MODE 5

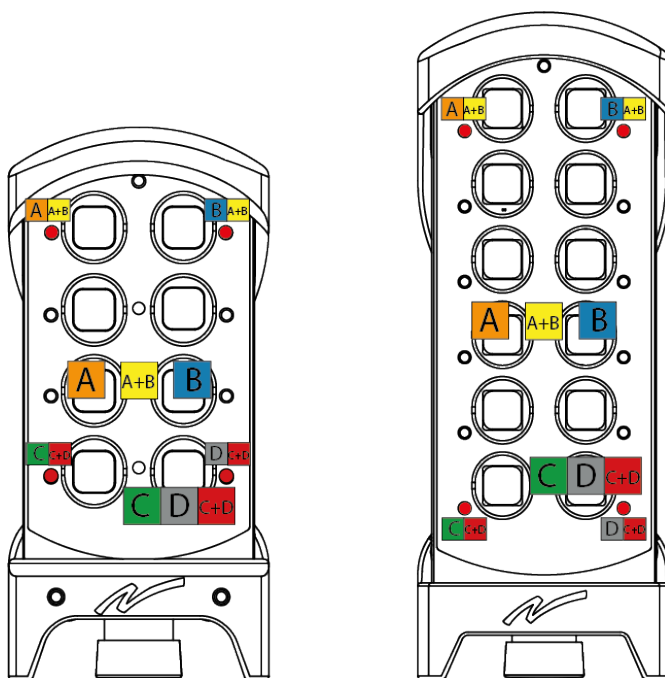

8.10.7 LOAD SELECT MODE 6

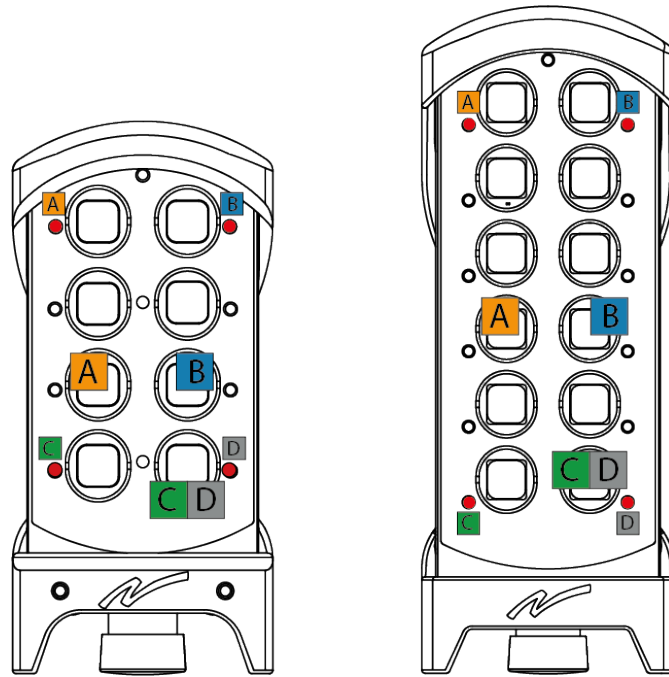

8.10.8 LOAD SELECT MODE 7

Load select mode 7 is set separately. Loads cannot be switched once the transmitter has been started. The LEDs on the transmitter do **not** indicate the activated load. Contact your representative for assistance.

CHAPTER 9: BATTERY

9.1 Battery precautions

Carefully read the following safety instructions and warnings before using, charging or disposing of the batteries.



Batteries contain flammable substances such as lithium or other organic solvents, which may result in overheating, rupture or combustion. Failure to read and follow the below instructions may result in fire, personal injury and damage to property if charged or used improperly.

9.1.1 HANDLING AND STORAGE



- Risk of explosion if battery is replaced with a battery of an incorrect type.
- Do not short-circuit, disassemble, deform or heat batteries.
- Never attempt to charge a visibly damaged or frozen battery.
- Do not use or charge the battery if it appears to be leaking, deformed or damaged in any way.
- Do not solder directly onto batteries.
- Do not leave the battery in the charger once it is fully charged.
- Store in a cool location. Keep batteries away from direct sunlight, high temperature, and high humidity.
- Immediately discontinue use of the battery if, while using, charging, or storing the battery, the battery emits an unusual smell, feels hot, changes color, changes shape, or appears abnormal in any other way.
- Keep batteries out of reach of small children. Should a child swallow a battery, consult a physician immediately.

9.1.2 DISPOSAL

When discarding batteries, insulate the + and - terminals of batteries with insulating/ masking tape.



- **Do not place multiple batteries in the same plastic bag.**
- **Do not incinerate or dispose of batteries in fire.**
- **Do not place used batteries in the household waste. Dispose of used batteries in accordance with the applicable regulations and legal requirements.**
- **Batteries that have been disposed of incorrectly may short circuit, causing them to become hot, burst or ignite.**

9.2 Battery information

NOTE: Only batteries approved by Tele Radio should be used in T9/T11 transmitters.

NOTE: When the battery capacity reaches approximately 10 %, the top LED lights red.

	T9-01, T9-11	T11-05, T11-15
Type of battery	Internal, rechargeable lithium-ion battery	Replaceable, rechargeable lithium-ion battery
Article number	-	M245060 (D4-02)
Operating time	~ 24 h with continuous usage	
Charge	Charger plug on the back of the transmitter	- Charger plug on the back of the transmitter or
Charger ¹	Tele Radio AB AC adapter	- Charger unit Tele Radio AB charger unit together with Tele Radio AB AC adapter
Article number	M769780	M769755 + M769780
Charging time	Approximately 4 hours with an empty battery	
Charging temperature	+10...+35 °C / +50...+95 °F	
Storage temperature	-20...+55 °C / -4...+130 °F	

¹Must be purchased separately.

9.2.1 REMOVAL OF THE INTERNAL BATTERY (T9)

Electronics and batteries must be physically separated before disposal.

1. Remove the clip. Use a screwdriver to remove the screws.
2. Remove the rubber cover by hand.
3. Use a screwdriver to remove the screws in the back of the transmitter.
4. Gently pull to release the back encapsulation (black).
5. Remove the back encapsulation by hand.
6. Turn it over so the circuit board is facing upwards.
7. Use a screwdriver to remove the screw(s) on the circuit board.
8. Unplug connectors, if any.
9. Gently lift up the circuit board by hand. The battery pack is located behind the circuit board.
10. Remove the battery by hand.

9.2.2 CHARGE THE BATTERY

NOTE: For T9 transmitters, the 1/O switch must be in the 1/on position when charging.

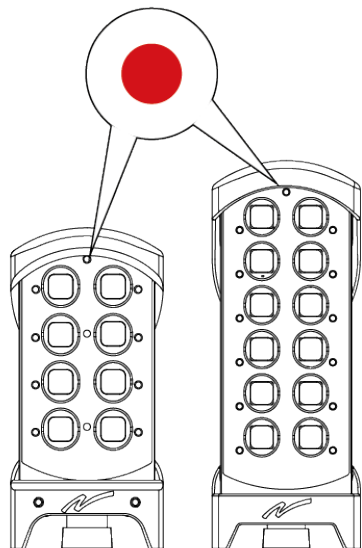

1. When the battery capacity reaches approximately 10 %, the top LED lights red and the internal buzzer beeps 3 times.

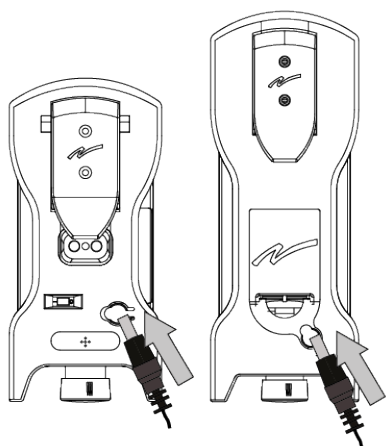

2. Lift the protection cap and insert the charger plug into the socket on the back of the transmitter. The top LED flashes red while the battery is charging.
If the transmitter has a replaceable rechargeable battery, it can be removed and recharged using the Tele Radio AB charger unit, see below.
Charger unit:

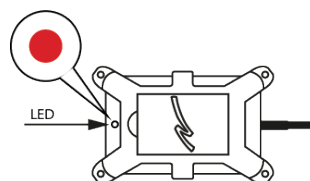

The charger's LED lights red while the battery is charging.

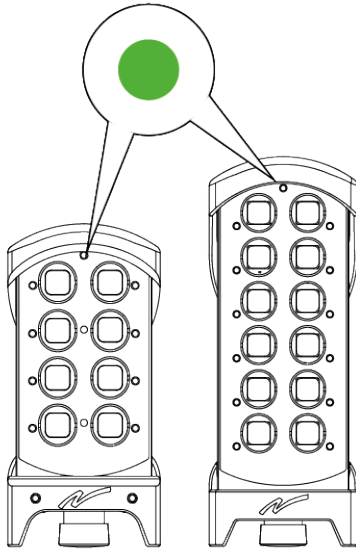

3. The top LED turns green when the battery is fully charged,.

Charger unit:

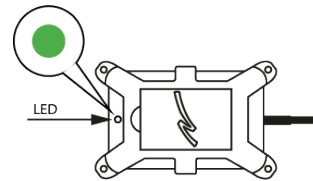

The charger's LED turns green when the battery is fully charged.

4. Remove the charger plug and close the protection cap.

For external batteries, remove the battery from the charger unit and put it back in the transmitter.

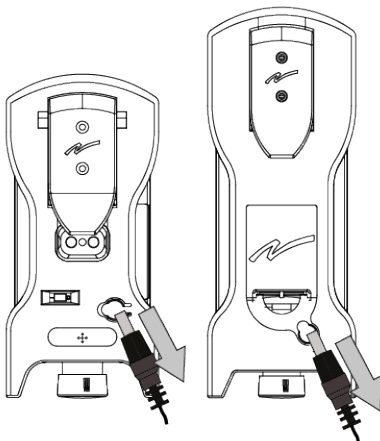

CHAPTER 10: FOILS

Foils are used to customized transmitters depending on the application. Tele Radio foils are made of durable, soft, flexible GO-PU/SM polyurethane film with a semi-matt surface on the front side.

Before affixing a foil to a transmitter, read the recommendation below.

- To obtain optimum adhesion, the bonding surfaces must be clean, dry and well unified. Some typical surface cleaning solvents are isopropyl alcohol (99.5%) or heptane.

NOTE: Carefully read and follow the manufacturer's precautions and directions for use when working with solvents. These cleaning recommendations may not be compliant with the rules of certain Air Quality Management Districts in California; consult applicable rules before use.

- Ideal tape application temperature range is 21 °C to 38 °C (70 °F to 100 °F).
- Initial tape application to surfaces at temperatures below 10 °C (50 °F) is not recommended because the adhesive becomes too firm to adhere readily. However, once properly applied, low temperature holding is generally satisfactory.

10.1 Affix a foil to the transmitter

1. Wipe the front of the transmitter with rubbing alcohol or other appropriate cleaner that won't leave any residue.
2. Dry with a clean cloth.
3. Peel off one side of the backing paper.
4. Position the side of the foil on the corresponding side of the transmitter.
5. While holding onto the side, gently press the foil onto the surface from the side out to the center.
6. Peel away the rest of the backing paper .
7. Slowly apply the other side of the foil, gently press from the center to the end.
8. Inspect the foil. If you see loose areas or bubbles, the surface probably wasn't warm or clean enough. Press the foil firmly against the surface to ensure good adhesion.

CHAPTER 11: WARRANTY, SERVICE, REPAIRS, AND MAINTENANCE

Tele Radio products are covered by a warranty against material, construction and manufacturing faults. During the warranty period, Tele Radio may replace the product or faulty parts. Work under warranty must be performed by Tele Radio or by an authorized service center specified by Tele Radio.

The following are **not** covered by the warranty:

- Faults resulting from normal wear and tear
- Parts of a consumable nature
- Products that have been subject to unauthorized modifications
- Faults resulting from incorrect installation and use
- Damp and water damage

Maintenance

- Repairs and maintenance must be performed by qualified personnel
- Only use spare parts from Tele Radio
- Contact your representative for service or any other assistance
- Keep the product in a clean, dry place
- Keep contacts and antennas clean
- Wipe off dust using a slightly damp, clean cloth

NOTE: Never use cleaning solutions or high-pressure washer.

CHAPTER 12: REGULATORY INFORMATION

NOTE: Models including additional naming conventions:

Model	Article names	Additional naming conventions
T9	T9-01	T9-1, T00009-01, TG-T9-1, TG-T9-01
	T9-11	T00009-11, TG-T9-11
T11	T11-05	T11-5, T00011-05, TG-T11-5, TG-T11-05
	T11-15	T00011-15, TG-T11-15

12.1 Europe

Applies to: **T9-01, T11-05**

12.1.1 CE MARKING

 Hereby, Tele-Radio i Lysekil AB, declares that the product(s) listed above is/are in compliance with the Radio Equipment Directive 2014/53/EU.

The latest version of the complete EU Declaration of Conformity is available at the following website: www.tele-radio.com.

12.1.2 WEEE DIRECTIVE



This symbol means that inoperative electrical and electronic products must not be mixed with household waste. The European Union has implemented a collection and recycling system for which producers are responsible. For proper treatment, recovery and recycling, please take this product to a designated collection point.

Tele Radio strives to minimize the use of hazardous materials, promotes reuse and recycling, and reduces emissions to air, soil and water. When a commercially viable alternative is available, Tele Radio strives to restrict or eliminate substances and materials that pose an environmental, health or safety risk.

12.2 North America

Applies to: **T9-11, T11-15**

12.2.1 FCC STATEMENT

This device complies with part 15 of the FCC Rules. Operation is subject to the following two conditions:

- (1) This device may not cause harmful interference, and
- (2) this device must accept any interference received, including interference that may cause undesired operation.

Changes or modifications not expressly approved by the party responsible for compliance could void the user's authority to operate the equipment.

This equipment has been tested and found to comply with the limits for a Class B digital device, pursuant to part 15 of the FCC Rules. These limits are designed to provide reasonable protection against harmful interference in a residential installation. This equipment generates uses and can radiate radio frequency energy and, if not installed and used in accordance with the instructions, may cause harmful interference to radio communications. However there is no guarantee that interference will not occur in a particular installation. If this equipment does cause harmful interference to radio or television reception, which can be determined by turning the equipment off and on, the user is encouraged to try to correct the interference by one or more of the following measures:

- Reorient or relocate the receiving antenna.
- Increase the separation between the equipment and receiver.
- Connect the equipment into an outlet on a circuit different from that to which the receiver is connected.
- Consult the dealer or an experienced radio/TV technician for help.

To satisfy FCC RF exposure requirements, a separation distance of 20 cm or more should be maintained between the antenna of this device and persons during device operation.

To ensure compliance, operations at closer than this distance is not recommended.

The radio module in this product is labelled with its own FCC ID and IC number. The FCC ID and IC is not visible when the radio module is installed inside another device. Therefore, the outside of the device into which the module is installed must also display a label referring to the radio module. The final end device must be labelled in a visible area with the following:

“Contains FCC ID: ONFC1108A”

“Contains IC: 4807A-C1108A”

12.2.2 IC STATEMENT

This product complies with Industry Canada's licence-exempt RSSs. Operation is subject to the following two conditions:

- (1) This device may not cause interference; and
- (2) This device must accept any interference, including interference that may cause undesired operation of device.

Le présent appareil est conforme aux CNR d'Industrie Canada applicables aux appareils radio exempts de licence. L'exploitation est autorisée aux deux conditions suivantes :

1. l'appareil ne doit pas produire de brouillage;
2. l'appareil doit accepter tout brouillage radioélectrique subi, même si le brouillage est susceptible d'en compromettre le fonctionnement.

To satisfy IC RF exposure requirements, a separation distance of 20 cm or more should be maintained between the antenna of this device and persons during device operation. To ensure compliance, operations at closer than this distance is not recommended.

Afin d'assurer la conformité aux exigences de la IC en matière d'exposition aux RF, une distance de séparation d'au moins 20 cm doit être maintenue entre l'antenne de cet appareil et toute personne à proximité pendant le fonctionnement de l'appareil. Pour assurer le respect de ces exigences, il n'est pas recommandé d'utiliser l'appareil à une distance inférieure à celle-ci.

The radio module in this product is labelled with its own FCC ID and IC number. The FCC ID and IC is not visible when the radio module is installed inside another device. Therefore, the outside of the device into which the module is installed must also display a label referring to the radio module. The final end device must be labeled in a visible area with the following:

Le module radio est étiqueté avec sa propre identification FCC et son propre numéro de certification IC. L'identification FCC et le numéro de certification IC ne sont pas visibles lorsque le module est installé à l'intérieur d'un autre dispositif, c'est la raison pour laquelle la partie externe du dispositif dans lequel le module est installé doit également présenter une étiquette faisant référence au module inclus. Le produit final doit être étiqueté sur une zone visible avec les informations suivantes :

“Contains FCC ID: ONFC1108A”

“Contains IC: 4807A-C1108A”

12.2.3 FCC/IC LABELS

The radio module in this product is labeled with its own FCC ID and IC numbers. The FCC ID and IC numbers are not visible when the radio module is installed inside another device. Therefore, the outside of the device into which the module is installed must also display a label referring to the enclosed radio module. The final end device must be labeled in a visible area with the following:

"Contains FCC ID: ONFC1108A"

"Contains IC: 4807A-C1108A"

The FCC and IC numbers are found on the product label.

12.2.4 RADIO MODULE

The following products described in these instructions contain the radio modules:

PRODUCT	RADIO MODULE
T9-11, T11-15	D00005-06

12.3 Brazil

Applies to: **T9-01, T11-05**

12.3.1 ANATEL STATEMENT (DECLARAÇÃO ANATEL)

Este equipamento não tem direito à proteção contra interferência prejudicial e não pode causar interferência em sistemas devidamente autorizados.

Este produto não é apropriado para uso em ambientes domésticos, pois poderá causar interferências eletromagnéticas que obrigam o usuário a tomar medidas necessárias para minimizar estas interferências.

ANNEX A: GLOSSARY

DC

Diagnostic Coverage

FIT

Failures in time (1 FIT = 1 failure per 10⁹ hours)

HFT

Hardware Fault Tolerance

MTTF

Mean Time To Failure

PFH

Probability of Failure per Hour

PL

Performance level

SFF

Safety Failure Fraction

SIL

Safety Integrity Level

ANNEX B: INDEX

A

ANATEL Statement	64
Automatic shutdown	46

B

Battery

Battery information	54
Charge	56
Removal of internal battery	55
Battery precautions	52
Handling	52
Storage	52

C

CE marking	60
Charging temperature	16, 54
Configuration menu	32

D

Dimensions	16
Disposal	53

E

Erase	43
-------------	----

F

FCC statement	61
FCC/IC labels	63
Foils	58
Frequency management	15
Functionality test	26

I	
IC Statement	62
Inactivity timeout	46
IP code	15
L	
Load select mode	47
Log out	31
Logout from Menu mode	42
Quick logout	31
M	
M245060	54
Maintenance	59
Menu mode	32
Enter Menu mode, no PIN code	33
N	
Number of channels	15
Number of frequency banks	15
O	
Operating temperature	16
Operating time	15
P	
Power supply	15
R	
Radio frequency band	15
433 MHz	17
915 MHz	18
Frequency channels	17

Radio frequency output power	15
Radio module	63
Register	37
Register in a receiver without display	38
Register the transmitter in a receiver with display	40
Register Register in R4 and R10 receivers	38
Register Register in R9 receivers	40
Replace	44
S	
Safety Features	12
Safety levels	16
Select a Radio frequency	35
Show current radio frequency channel	34
Start-up protection	25
Start a session	27
Start with PIN code	29
Start the transmitter	27
Start with PIN code	29
Stop button	12
Stop function	13
Storage temperature	
Battery	54
Switch off	31
T	
Top LED	21-22
Transmitter back	20
Transmitter front views	19

W

Warnings & restrictions	9
Installation and commission	9
Maintenance	11
Operation	10
WEEE directive	60
Weight	16

This page intentionally left blank.

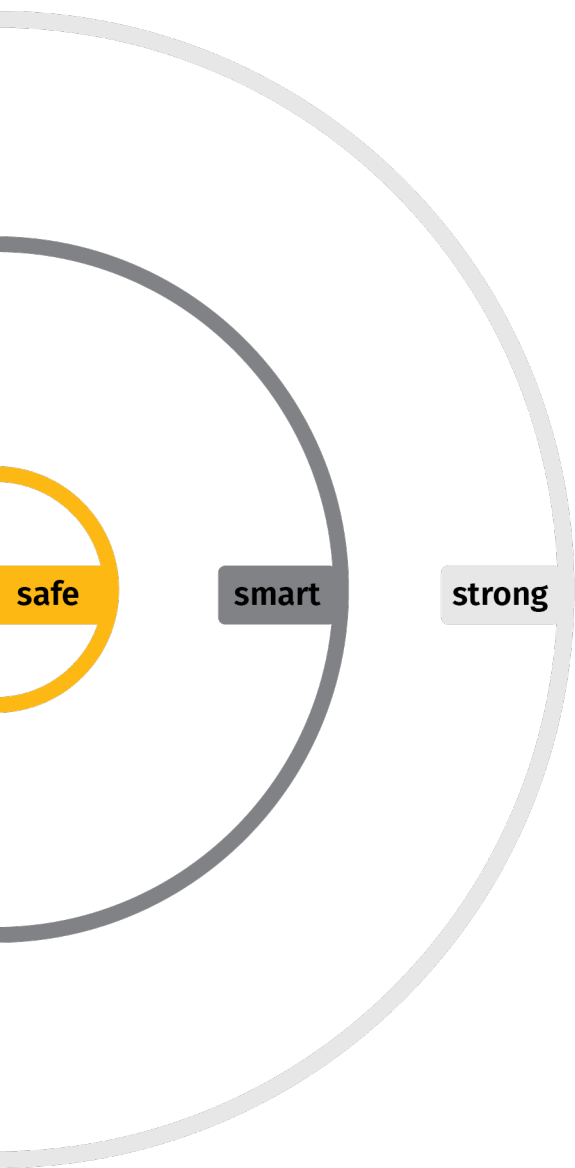

 **tele radio**[®]
wireless solutions

These Installation instructions are subject to change without prior notice.
Download the latest instructions from www.tele-radio.com.