

INSTALLATION INSTRUCTIONS

*Receivers: R15-01, R15-02,
R15-07, R15-08,
R15-13, R15-14*

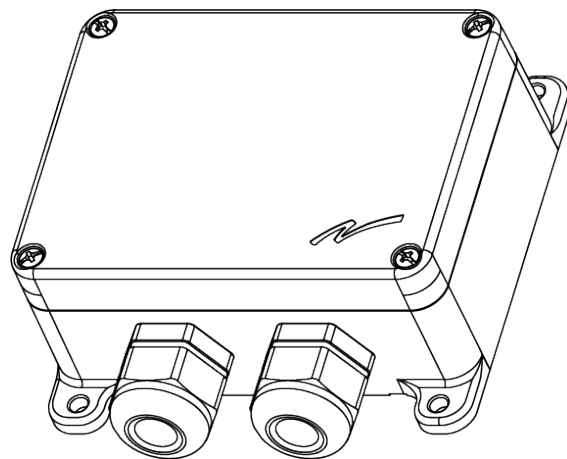

IMPORTANT! This document is intended for R15 receivers with software version SW0014-14v24 or higher.

For receivers with software version SW0014-14v23 or lower, please refer to the installation instructions IM-PN-RX103-A04-EN.

©Tele Radio AB

Datavägen 21

SE-436 32 Askim

Sweden

Phone: +46 (0)31 748 54 60

CONTENTS

CHAPTER 1: INTRODUCTION	5
1.1 About this document	7
1.2 About R15 receivers	8
CHAPTER 2: SAFETY	9
2.1 Warnings & restrictions	9
CHAPTER 3: FUNCTIONAL SAFETY	13
3.1 Safety function	13
3.2 Applicable products	13
3.3 Installation	13
3.4 Configuration	14
3.5 Interface	15
CHAPTER 4: TECHNICAL DATA	16
4.1 Receiver specifications	16
4.2 Current consumption	17
CHAPTER 5: PRODUCT GENERAL DESCRIPTION	18
5.1 Receiver description	18
5.2 Mechanical installation	19
CHAPTER 6: BOARD DESCRIPTION	21
6.1 Base board – R15-01, R15-02, R15-07, R15-08 –	22
6.2 Base board – R15-13, R15-14 –	24
6.3 6-Relay expansion board	26
CHAPTER 7: STATUS AND ERROR INDICATIONS	27
7.1 Relay LEDs indication in normal operation	27
7.2 Function LEDs indication in normal operation	28
7.3 Error codes	29
CHAPTER 8: OPERATION	30
8.1 General information	30
8.2 Radio mode	31
8.3 Login/logout function	31
8.4 Relay functions	31
CHAPTER 9: CONFIGURATION MENU	32
9.1 Menu mode	32

9.2 Register a transmitter in the receiver	33
9.3 Set momentary or latching relay functions	34
9.4 Operating modes	35
9.5 Active Load select	42
9.6 Log a transmitter out	43
9.7 Erase all registered transmitters	44
9.8 Master reset of the receiver	44
CHAPTER 10: WARRANTY, SERVICE, REPAIRS, AND MAINTENANCE	45
CHAPTER 11: REGULATORY INFORMATION	46
11.1 Europe	46
11.2 AEC	47
ANNEX A: FREQUENT TERMS	48
ANNEX B: INDEX	50

CHAPTER 1: INTRODUCTION

Thank you for purchasing a Tele Radio AB product



READ ALL INSTRUCTIONS AND WARNINGS CAREFULLY BEFORE MOUNTING, INSTALLING, CONFIGURING AND OPERATING THE PRODUCTS.

These Installation instructions have been published by Tele Radio AB and are not subject to any guarantees. The Installation instructions may be withdrawn or revised by Tele Radio AB at any time and without further notice. Corrections and updates will be added to the latest version of the manual. Always download the Installation instructions from our website, www.tele-radio.com, for the latest available version. Keep the safety instructions for future reference.

IMPORTANT! These instructions are intended for installers and authorized service and distribution centers. The instructions containing information about the installation and configuration of the radio remote control unit on the machine are NOT intended to be passed on to the end user. Only information that is needed to operate the machine correctly by radio remote control may be passed on to the end user.

Tele Radio AB remote controls are often built into wider applications. This documentation is not intended to replace the determination of suitability or reliability of the product for specific user applications and should not be used for this purpose. It is the responsibility of any such users or integrators to perform the appropriate and complete risk analysis, evaluation and testing of the products with respect to the relevant specific application or use. Tele Radio AB shall not be responsible or liable for misuse of the information contained herein.

Always refer to the applicable local regulations for installation and safety requirements relating to cranes, hoists, material handling applications, lifting equipment, industrial machinery, and/or mobile hydraulic applications using Tele Radio AB products, e.g.:

- applicable local and industrial standards and requirements,
- applicable occupational health and safety regulations,
- applicable safety rules and procedures for the factory where the equipment is being used,
- user and safety manuals or instructions of the manufacturer of the equipment where Tele Radio AB remote control systems are installed.

Tele Radio AB Installation instructions do not include or address the specific instructions and safety warnings of the end product manufacturer.

Tele Radio AB products are covered by a warranty against material, construction, or manufacturing faults. See "Chapter 10: Warranty, service, repairs, and maintenance".

1.1 About this document

Before installing or operating the product, read the corresponding documentation carefully.

Tele Radio AB's product range is composed of transmitters, receivers, and accessories intended for use together as a system.

These Installation instructions cover general safety issues, main technical specifications, standard installation, configuration and operating instructions, as well as general troubleshooting. Images shown in this document are for illustrative purposes only.

Please report any error or omission in this document, as well as any improvement or amendment suggestion to td@tele-radio.com.

1.1.1 TERM AND SYMBOL DEFINITIONS

The capitalized terms and symbol used herein shall have the following meaning:

- **WARNING:** indicates a hazardous situation which, if not avoided, could result in death or serious injury.
- **CAUTION:** indicates a hazardous situation which, if not avoided, will result in minor or moderate injury.
- **IMPORTANT:** is used for information that requires special consideration.
- **NOTE:** is used to address practices not related to physical injury.



This symbol is used to call attention to safety messages that would be assigned the signal words "WARNING" or "CAUTION".

1.2 About R15 receivers

R15 receivers have simplex communication and work in either discontinuous or continuous mode.

There are six models.

	Base board	Base board	Expansion board
	48-230 V AC	12-24 V AC/DC	6-relay
R15-01	● (48-230 V AC)	-	○
R15-02	● (48-230 V AC)	-	●
R15-07	● (24-48 V AC)	-	○
R15-08	● (24-48 V AC)	-	●
R15-13	-	●	○
R15-14	-	●	●

● Standard ○ Optional¹ - Not available

¹Must be purchased separately.

CHAPTER 2: SAFETY

2.1 Warnings & restrictions



Carefully read through the following safety instructions before proceeding with the installation, configuration, operation, or maintenance of the product. Failure to follow these warnings could result in death or serious injury.

This product must not be operated without having read and understood the Installation instructions, the specific technical documentation (for customized systems), and having received the appropriate training. The purchaser of this product has been instructed how to handle the system safely. The following information is intended for use as a complement to applicable local regulations and standards.

IMPORTANT! Tele Radio AB remote controls are often built into wider applications. These systems should be equipped with:

- a wired emergency stop where necessary
- a brake
- an audible or visual warning signal

2.1.1 INSTALLATION AND COMMISSIONING

IMPORTANT! Only licensed or qualified personnel should be permitted to install the product.



This radio system must not be used in areas where there is a risk of explosion.



Always switch off all electrical power from the equipment before installation procedure.



To utilize the safety features of the system, use the stop relays in the safety circuitry of the object/ equipment to be controlled.



When the equipment controlled by the receiver's standard relays is connected via the stop relays, make sure that the maximum current through the stop relays is still within the specifications. Contact your representative for assistance.



RISK OF UNINTENDED EQUIPMENT OPERATION

Only transmitters that are intended for use should be registered in the receiver.

Failure to follow these instructions could result in death, serious injury, or equipment damage.



RISK OF ELECTRIC SHOCK

The receiver must only be opened by qualified installers or authorized personnel.

Make sure the power supply is switched off before opening the receiver. Failure to follow these instructions could result in death, serious injury, or equipment damage.



- **The receiver must be securely attached and located where it will not be hit by e.g. any moving parts.**
- **Do not install the product in areas affected by strong vibrations**
- **Cable glands and vent plugs must face downwards to prevent water ingress.**
- **Ensure that the power supply is connected to the correct terminals.**
- **Ensure that flexible cords and cables are not damaged through friction or stress.**
- **Do not use damaged cables.**
- **Ensure cables and connectors do not hang loose.**

- The receiver is designed to withstand normal weather conditions but should be protected from extreme conditions.
- Mount the receiver in a location where the LEDs are easily visible and the buttons accessible.
- Make sure to install available accessories inside or on the receiver before permanently installing the receiver. A permanent installation of the product

must include fuse protection of the equipment and cables against short circuits.

2.1.2 OPERATION



Only qualified personnel should be permitted to access the transmitter and operate the equipment.



- **Make sure that the user satisfies the age requirements in your country for operating the equipment.**
- **Make sure that the user is not under the influence of drugs, alcohol and medications.**
- **Make sure that the user knows and follows operating and maintenance instructions as well as all applicable safety procedures and requirements.**

The user should:



- **Always test the transmitter stop button before operating it. This test should be done on each shift, without a load.**
- **Never use a transmitter if the stop button is mechanically damaged. Contact your supervisor or representative for service immediately.**
- **Never leave the transmitter unattended.**
- **Always switch the transmitter off when not in use. Store in a safe place.**
- **Keep a clear view of the work area at all times.**

2.1.3 MAINTENANCE



Before maintenance intervention on any remote controlled equipments:

- **always remove all electrical power from the equipment.**
- **always follow lockout procedures.**

- Keep the safety information for future reference. Always download the Installation instructions from our website, www.tele-radio.com, for the latest available version.
- If error messages are shown, it is very important to find out what caused them. Contact your representative for help.

- The functionality of the stop button should be tested at least after every 200 hours' use.
- If the stop button is mechanically damaged, do not use the transmitter. Contact your supervisor or representative for service immediately.
- Keep contacts and antennas clean.
- Wipe off dust using a clean, slightly damp cloth.
- Never use cleaning solutions.
- Check the encapsulation, foils and cable for damages. If the encapsulation or foil is damaged, moisture can cause serious damage to the electronics.

CHAPTER 3: FUNCTIONAL SAFETY

NOTE: The information in this section applies only to the products specified below.

3.1 Safety function

The safety-related stop function in the radio system complies with **EN 13849-1:2015 PLd category 3**. The stop relays on the receiver unit are controlled by the stop button on the transmitter unit. When the stop button is pressed, the stop relays interrupt the power to the safety-related application. The complete end-user system, including the radio system, enters a safe state. The maximum response time for the safety-related stop function is 500 ms.

Safety function	Mission time	MTTFd	DC _{avg}	Category	Achieved PL
Stop function	20 years	100 years	95 %	3	d

3.2 Applicable products

The following products are designed to comply with the appointed safety requirements:

Receivers: **R15-01, R15-02, R15-07, R15-08, R15-13, R15-14**

Transmitter: **T19-02**

NOTE: Both the receiver and the transmitter used in the specific end-user system must be compliant.

3.3 Installation

The stop relays on the receiver unit shall be correctly installed on the end-user system, to ensure that opened/deactivated stop relays interrupt the power to the safety-related application. The safety level of the stop function can only be credited when used in a complete end-user system that complies with EN 13849-1:2015 PLd category 3.

NOTE: The safety level of the stop function on the complete end-user system depends on other subsystem(s) and needs to be calculated by the manufacturer of the complete system.

3.4 Configuration

Depending on the selected Operation Mode¹, the default configuration of the receiver unit complies with the appointed safety requirements. Any reconfiguration that breaches the safety requirements will be indicated by a LED on the main board of the receiver unit. Before commissioning the radio system, the installer must check the LED indication.

Function LED	Status	Indicates
PLd status LED (red)	ON	Not compliant with PLd
	OFF	Compliant with PLd

R15-01, R15-02, R15-07, R15-08

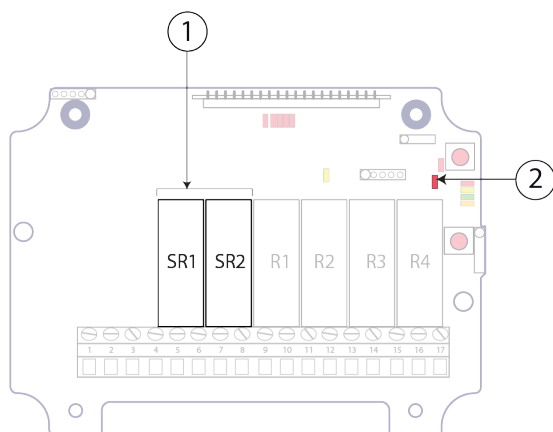

R15-13, R15-14

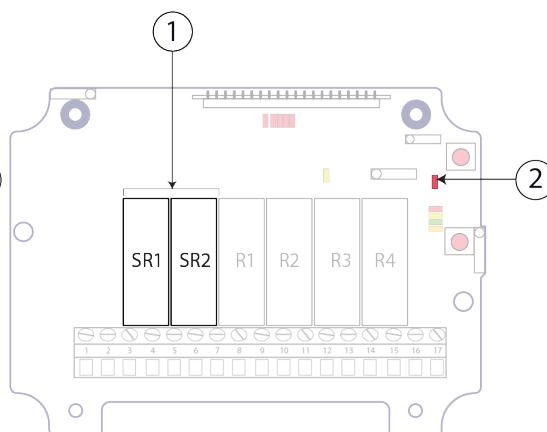

1. Stop relays
2. PLd status LED

IMPORTANT! All safety-related parameters must be configured as follows in order to comply with the appointed safety requirements:

- The system must be configured in continuous radio mode.
- All relays must be switched off when the radio link is down.
- The radio link timeout must be set to a maximum of 500 ms.
- The login/logout function must be activated.
- The Custom ID setting must be deactivated, i.e. the receiver must always use the unique transmitter ID code.
- The parameter "Require start command" must be activated. See below for more details.

¹See "9.4 Operating modes".

3.4.1 'REQUIRE START COMMAND' PARAMETER

When a T19-02 transmitter is started it will send start commands for 200 ms.

- **If 'Require start command' is activated, the receiver is PLd compliant.**

The receiver will not activate the stop relays until it receives a start command from the transmitter. This is to make sure that the stop relays will not activate immediately if the receiver is restarted after a temporary loss of power and the transmitter is still active.

If the receiver has received a start command and the transmitter goes out of range for more than six minutes, a new start packet will be required (i.e. the transmitter will have to be restarted).

- **If 'Require start command' is not checked, the receiver is NOT PLd compliant.**

The stop relays are activated as soon as the receiver receives packets without pressing any button on the transmitter.

3.5 Interface

The radio system comprises one SRP/CS (as defined in EN 13849-1:2015), including the stop button (input), the stop relays (output) and the safety-related logic maintaining the stop function (logic).

The interfaces to the SRP/CS are the stop button (as controlled by the operator) and the stop relays.

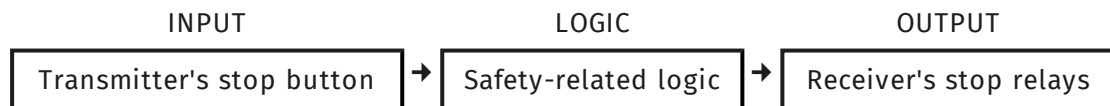

→: Interconnection

CHAPTER 4: TECHNICAL DATA

4.1 Receiver specifications

NOTE: When the equipment controlled by the receiver's standard relays is connected via the stop relays, make sure that the maximum current through the stop relays is still within the specifications.

	R15-01	R15-02	R15-07	R15-08	R15-13	R15-14
Power supply	48–230 V AC [-12%...+15%]		24–48 V AC [-8%...+25%]		12–24 V AC/DC [-40%...+35%]	
Number of stop relays	2 (potential free*)					
Stop relays maximum resistive load	10 A, 250 V AC					
Stop relays maximum inductive load	4 A, 250 V AC					
Number of relays	4	10	4	10	4	10
	(potential free*, 10A, 250V AC or 30 V DC) ¹					
Relay functionality	Momentary, latching, interlocking (programmable)					
Digital inputs	0					
Radio frequency band	2405–2480 MHz					
Number of channels	16 (channel 11–26)					
Radio communication	Simplex					
Max. number of registered transmitters	8					
Antenna	Internal antenna					
IP code	IP66					
Operating temperature	-20...+55 °C / -4...+130 °F					
Safety levels	EN ISO 13849-1, PLd CAT3 (Stop function, see "Chapter 3: Functional safety")					
Dimensions	120 x 117 x 51 mm / 4.7 x 4.6 x 2 in					
Weight	400 g / 0.8 lbs					

* Potential free means that a supply voltage is needed to get voltage out of a relay.

¹ For resistive load only.

4.2 Current consumption

Input power	R15-01, R15-02		R15-07, R15-08		R15-13, R15-14	
	Min.*	Max.**	Min.*	Max.**	Min.*	Max.**
12 V AC	–	–	–	–	0.03 A	0.3 A
24 V AC	–	–	0.02 A	0.2 A	0.02 A	0.2 A
48 V AC	0.01 A	0.09 A	0.01 A	0.09 A	–	–
115 V AC	0.005 A	0.03 A	–	–	–	–
230 V AC	0.003 A	0.02 A	–	–	–	–
12 V DC	–	–	0.03 A	0.3 A	0.03 A	0.3 A
24 V DC	–	–	0.02 A	0.2 A	0.02 A	0.2 A

*Minimum current consumption = Receiver powered, no active relays, no radio session established.

**Maximum current consumption = Receiver powered, all relays on the receiver active, radio session established.

CHAPTER 5: PRODUCT GENERAL DESCRIPTION

The pictures shown in this chapter are for illustrative purposes only.

5.1 Receiver description

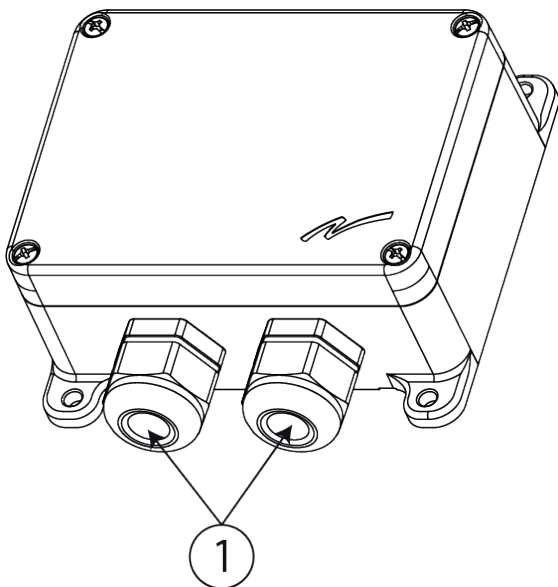

1. Cable glands (M20x1.5)

5.2 Mechanical installation

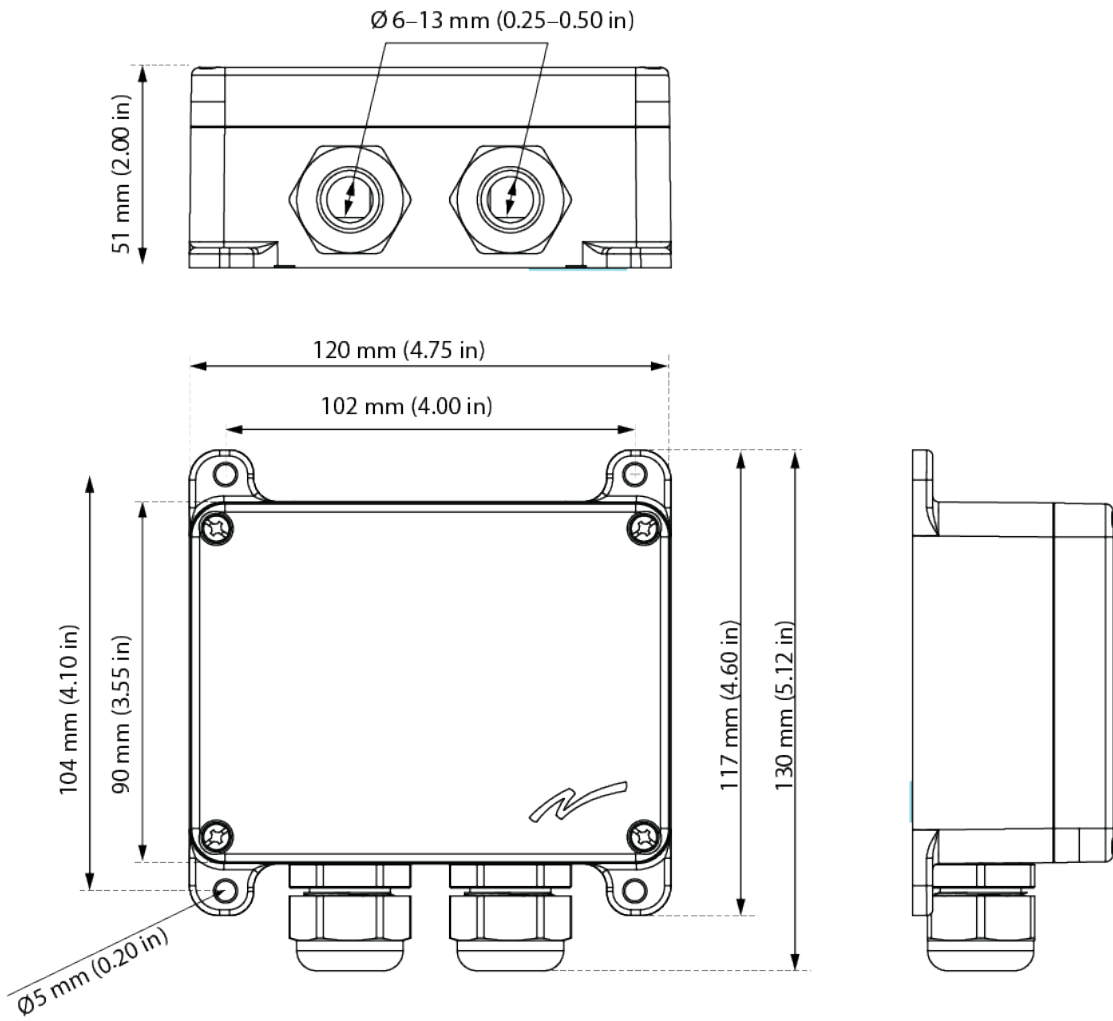

5.2.1 INSTALLATION PRECAUTIONS

RISK OF ELECTRIC SHOCK



The receiver must only be opened by qualified installers or authorized personnel.

Make sure the power supply is switched off before opening the receiver. Failure to follow these instructions could result in death, serious injury, or equipment damage.

IMPORTANT! Only authorized personnel should install the product.

Only correct installation complies with the safety levels for the product.

- A permanent installation of the receiver must include fuses in order to protect the equipment and cables from short circuit.
- The receiver must be installed vertically, on a flat and rigid surface, with the cable at the bottom.
- Mount the receiver in a location where the LEDs are easily visible and the buttons on the receiver accessible.
- Consider the wiring limitation and the radio communication limitation to choose the receiver location.
- Ensure no obstacle is impairing the radio communication performance between the receiver and the transmitter.
- The receiver must not be installed inside closed metal containers.
- Make sure any accessories inside or on the receiver are installed before permanently installing the receiver.
- Test the equipment before installing the receiver permanently.

CHAPTER 6: BOARD DESCRIPTION

NOTE: The pictures shown in this chapter are for illustrative purposes only. Depending on the configuration, the actual product appearance may differ from the basic model used for reference.

RISK OF ELECTRIC SHOCK

The receiver must only be opened by qualified installers or authorized personnel.



Make sure the power supply is switched off before opening the receiver. Failure to follow these instructions could result in death, serious injury, or equipment damage.

IMPORTANT! Only experienced electronic technicians should add and map expansion boards and inputs/outputs.

6.1 Base board – R15-01, R15-02, R15-07, R15-08 –

NOTE: This board is integrated in the following models: R15-01, R15-02, R15-07, R15-08 .

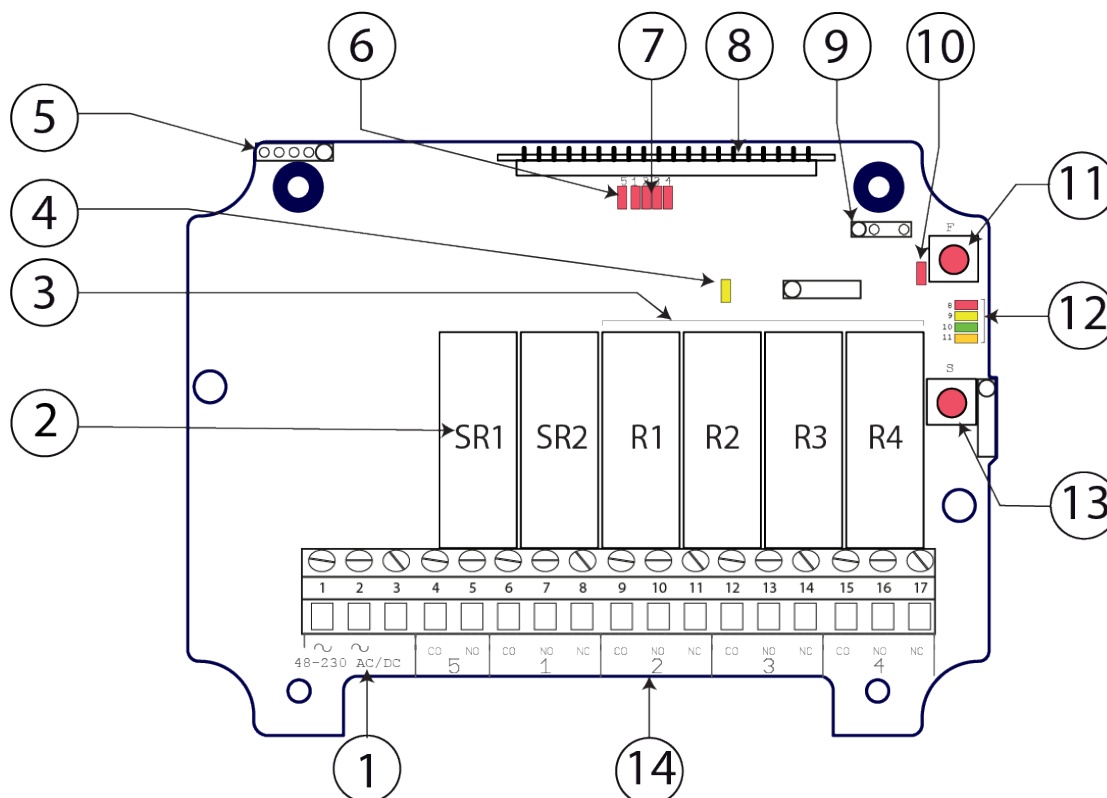

- | | |
|--|--|
| 1. Terminal block for input power | 8. Radio module |
| 2. Stop relays SR1-2 ¹ (NO) | 9. Programming contact |
| 3. Function relays 1-4 (NO/NC) | 10. PLd status LED |
| 4. Power LED (yellow) | 11. Function button (Cancel) |
| 5. Connector for 6-relay expansion board | 12. Function LEDs
(8 = red, 9 = yellow,
10 = green, 11 = orange) |
| 6. LED indicator for stop relays (5)* | 13. Select button (OK) |
| 7. Relay LEDs (1-4)* | 14. Terminal block for stop relays (5)
and function relays (1-4)** |

*For more information, see "7.1 Relay LEDs indication in normal operation".

**For more information, see "6.2.2 Terminal block for relays on the base board".

¹Also called "relay 5".

6.1.1 TERMINAL BLOCK FOR INPUT POWER ON THE BASE BOARD – R15-01, R15-02, R15-07, R15-08 –

The power source to the receiver unit must fulfill the definition of LPS (Limited Power Source) according to EN 60950-1. The maximum available output power should be either 240 VA (fuse protected) or 100 VA (without fuse).

R15-01, R15-02

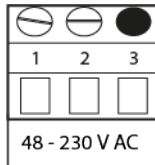

1. 48–230 V AC
2. 48–230 V AC
3. (not in use)

R15-07, R15-08

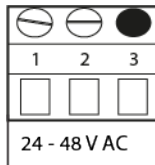

1. 24–48 V AC
2. 24–48 V AC
3. (not in use)

6.1.2 TERMINAL BLOCK FOR RELAYS ON THE BASE BOARD

NOTE: Applies to both base boards.

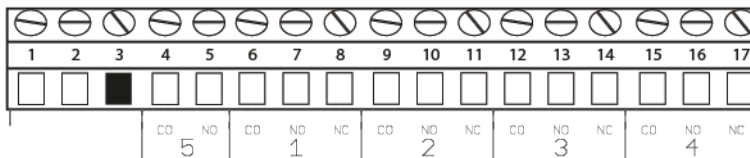

Pin numbers	Relay number	Relay name	Contact
4–5	5	SR1–2 (stop relays)	CO–NO
6–8	1	Function relay 1	CO–NO/NC
9–11	2	Function relay 2	CO–NO/NC
12–14	3	Function relay 3	CO–NO/NC
15–17	4	Function relay 4	CO–NO/NC

6.2 Base board – R15-13, R15-14 –

NOTE: This board is integrated in the following models: R15-13 and R15-14.

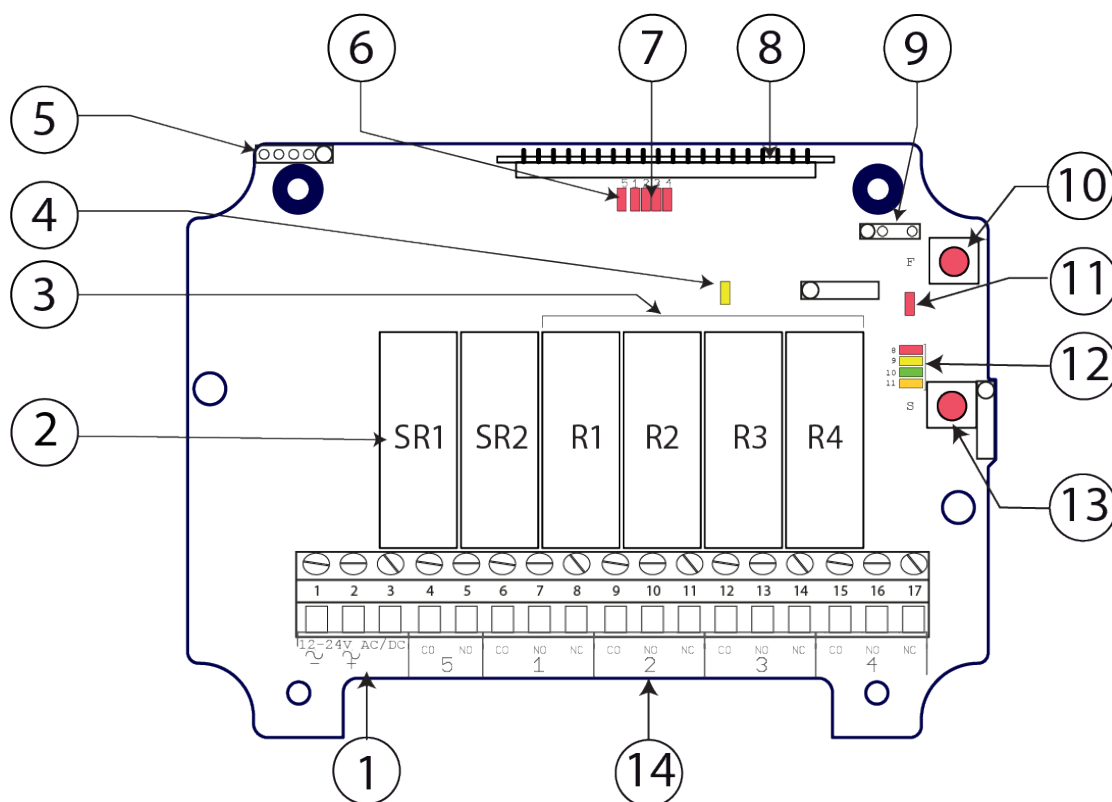

- | | |
|--|--|
| 1. Terminal block for input power (48-230 V AC/DC) | 8. Radio module |
| 2. Stop relays SR1-2 ¹ (NO) | 9. Programming contact |
| 3. Function relays 1-4 (NO/NC) | 10. Function button (Cancel) |
| 4. Power LED (yellow) | 11. PLd status LED |
| 5. Connector for 6-relay expansion board | 12. Function LEDs (8 = red, 9 = yellow, 10 = green, 11 = orange) |
| 6. LED indicator for stop relays (5)* | 13. Select button (OK) |
| 7. Relay LEDs (1-4)* | 14. Terminal block for stop relays (5) and function relays (1-4)** |

*For more information, see "7.1 Relay LEDs indication in normal operation".

**For more information, see "6.2.2 Terminal block for relays on the base board".

¹Also called "relay 5".

6.2.1 TERMINAL BLOCK FOR INPUT POWER ON THE BASE BOARD – R15-13, R15-14 –

The power source to the receiver unit must fulfill the definition of LPS (Limited Power Source) according to EN 60950-1. The maximum available output power should be either 240 VA (fuse protected) or 100 VA (without fuse).

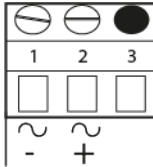

1. Negative terminal DC voltage
2. ~ + 12-24 V AC/DC
3. (not in use)

6.2.2 TERMINAL BLOCK FOR RELAYS ON THE BASE BOARD

NOTE: Applies to both base boards.

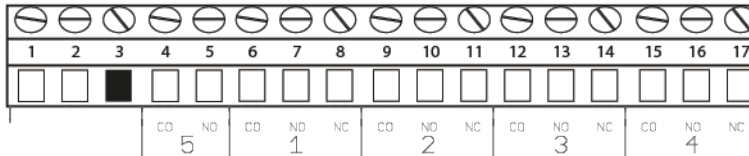

Pin numbers	Relay number	Relay name	Contact
4-5	5	SR1-2 (stop relays)	CO-NO
6-8	1	Function relay 1	CO-NO/NC
9-11	2	Function relay 2	CO-NO/NC
12-14	3	Function relay 3	CO-NO/NC
15-17	4	Function relay 4	CO-NO/NC

6.3 6-Relay expansion board

NOTE: This board is integrated in the following models: R15-02 and R15-14.

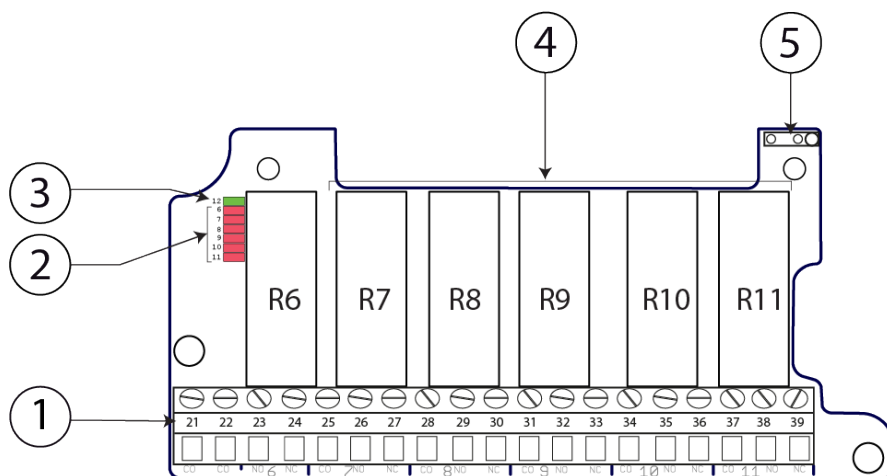

- 1. Terminal blocks for function relays 6-11
- 2. LED indicators for function relays 6-11 (red)
- 3. Communication LED (green)
- 4. Function relays 6-11 (NO/NC)
- 5. Programming contact

6.3.1 POSITIONING OF THE 6-RELAY BOARD

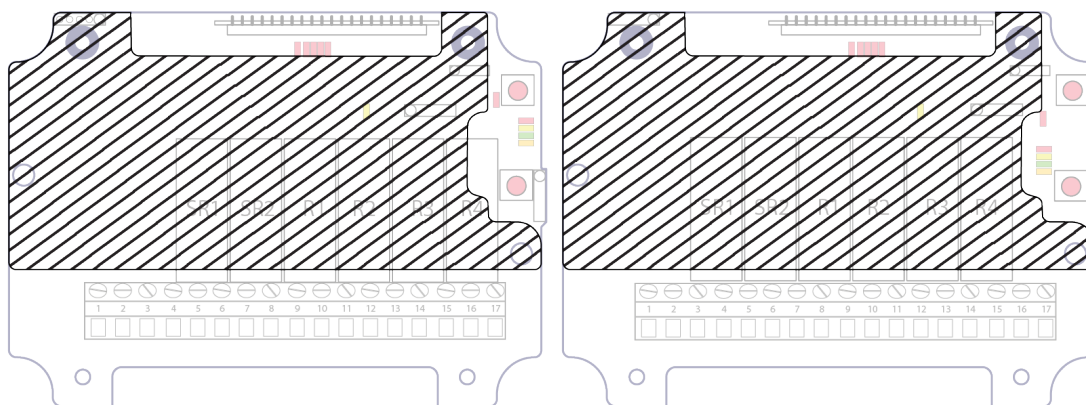

R15-01, R15-02, R15-07, R15-08

R15-13, R15-14

CHAPTER 7: STATUS AND ERROR INDICATIONS

LEDs 1–5 are called relay LEDs, LED 7 is the PLd status LED and LEDs 8–11 are called function LEDs.

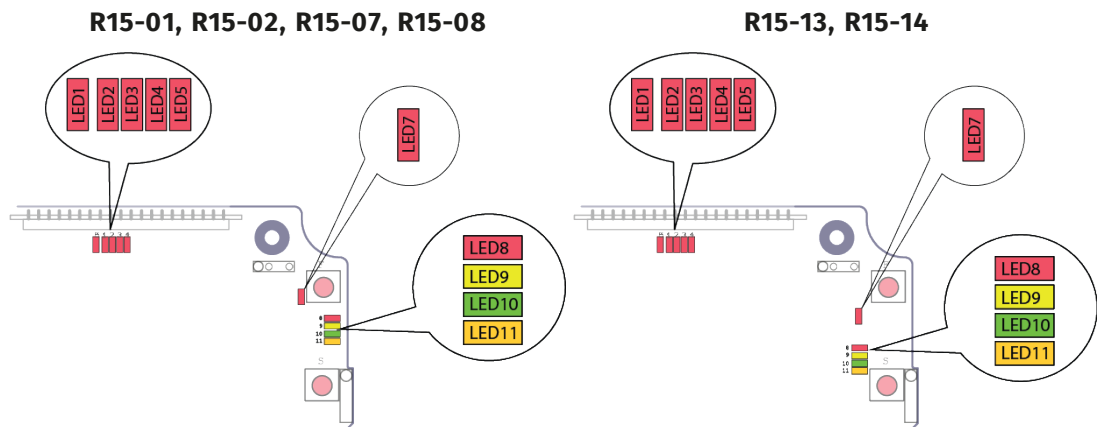

7.1 Relay LEDs indication in normal operation

The numbers above the five red leds (LED1–5) correspond to the relay numbers: 5= stop relays SR1–2; 1–4 = function relays 1–4.

LED number	LED1	LED2	LED3	LED4	LED5
Relay number	5	1	2	3	4
Stop relays SR1–2	●				
Function relay 1		●			
Function relay 2			●		
Function relay 3				●	
Function relay 4					●

7.2 Function LEDs indication in normal operation

LED	Color	Off	On	Flashing	Description
7	red		●		Not compliant with PLd.
		○			Compliant with PLd.
8	red	○			No transmitter is registered.
			●	Single flash	One or more transmitters are registered.No radio link.
			●	Double flash	One or more transmitters are registered and logged in.No radio link.
			●		Radio link established.
9	yellow		●		Receiving a radio packet from a transmitter other than a Panther.
9	yellow		●		Receiving a radio packet from a transmitter set to a different radio mode (discontinuous or continuous) than the receiver.
10	green		●		
9	yellow		●		Receiving a radio packet from a transmitter that is not registered.
11	orange		●		
10	green		●		Receiving a radio packet, low signal (RSSI).
11	orange		●		Receiving a radio packet, configuration ID not accepted.
10	green		●		Receiving a radio packet, custom ID not accepted.
11	orange		●		
9	yellow		●		1. Receiving a radio packet from a registered transmitter. The receiver is already controlled by another registered transmitter. NOTE: "Radio link" must be activated in the receiver. 2. Load select mode is activated. Incorrect Load is selected on the transmitter.
10	green		●		
11	orange		●		

7.3 Error codes

If an error occurs that requires the attention of Tele Radio AB, all function LEDs will flash. At the same time, one or more relay LEDs will light up. Write down the error code and contact your representative for assistance.

CHAPTER 8: OPERATION

8.1 General information

8.1.1 RECEIVERS WITH LOGIN/LOGOUT¹ FUNCTION ACTIVATED

To control a receiver, the transmitter must be registered and logged in to the receiver. If another transmitter is already logged in to the receiver, it must be logged out before a different transmitter can be logged in.

If no transmitter is logged in to the receiver, the first registered transmitter to be started will automatically log in to the receiver. Once a transmitter has been logged in, it will remain logged in until it is manually logged out.

More than one transmitter can be registered in the receiver, but only one transmitter can be logged in at a time.

8.1.2 RECEIVERS WITHOUT LOGIN/LOGOUT FUNCTION OR WITH LOGIN/LOGOUT FUNCTION INACTIVATED

To control a receiver, the transmitter must be registered in the receiver.

If no transmitter is controlling the receiver, the first registered transmitter to be started will automatically take control of the receiver. Switching the transmitter off will free the receiver and allow any other registered transmitter that is started to control the receiver.

More than one transmitter can be registered in the receiver, but only one transmitter can control the receiver at a time.

NOTE: If the login/logout function is inactivated the receiver is not PLd compliant.

8.1.3 MULTIPLE TRANSMITTERS REGISTERED IN A SAME RECEIVER

If more than one transmitter is registered in the same receiver, it is recommended to select the same frequency channel on all transmitters.

¹For more information about login/logout, see "8.3 Login/logout function"

8.2 Radio mode

NOTE: The radio mode is determined by the selected **Operating mode**. To establish a radio link between the transmitter and receiver, both units need to be set to the same radio mode.

This receiver is set to **continuous** radio mode by default.

Some settings can only be selected when the products are transmitting continuously. These settings are marked with the text: "Only for continuous radio mode".

8.3 Login/logout function

NOTE: Only for **continuous** radio mode.

NOTE: The login/logout function cannot be activated/deactivated in the receiver. Contact your representative for assistance.

For this receiver, the login/logout function is activated by default.

Logging out means stopping the communication between the transmitter and the receiver, and freeing the receiver for another registered transmitter to log in.

8.4 Relay functions

This receiver is set to **momentary** relay functionality by default. The relay remains active while a button is pressed on the transmitter. When the button is released the relay deactivates. Setting a relay to latching means that the relay becomes active when a button is pressed and remains active until the button is pressed again.

CHAPTER 9: CONFIGURATION MENU

All configuration settings require access to the receiver circuit board(s).



RISK OF ELECTRIC SHOCK

The receiver must only be opened by qualified installers or authorized personnel.

Make sure the power supply is switched off before opening the receiver.

Failure to follow these instructions could result in death, serious injury, or equipment damage.

1. Remove the front cover of the receiver. Use a screwdriver to remove the screws.
2. Power the receiver up.
3. The power LED lights (yellow).
4. Proceed with the configuration instructions of your choice.

9.1 Menu mode

To select the different menus, press the **Function** button a predefined number of times according to the following table. Press the **Select** button to enter.

The different menus are identified by the function LEDs 8–11 (see "Chapter 7: Status and error indications").

●: LED is lit. ○: LED is off.

Menu	To select the menu, press the Function button...	Function LEDs light			
		LED 8 (red)	LED 9 (yellow)	LED 10 (green)	LED 11 (orange)
Register/Erase transmitters	once	●	○	○	○
Show/Change latching/momentary functions	2 times	○	●	○	○
Show settings	3 times	○	○	●	○
Show/Change Operating mode	4 times	○	○	○	●

9.2 Register a transmitter in the receiver



RISK OF UNINTENDED EQUIPMENT OPERATION

Only transmitters that are intended for use should be registered in the receiver.

Failure to follow these instructions could result in death, serious injury, or equipment damage.



RISK OF UNINTENDED EQUIPMENT OPERATION

Do not perform this action when the receiver is in a session with another transmitter. The radio communication may be interrupted or broken.

Failure to follow these instructions could result in death, serious injury, or equipment damage.

NOTE: To establish a radio link between the transmitter and the receiver, both units must be set to the same radio mode.

1. Set the transmitter in registration mode (see relevant Tele Radio AB transmitter installation instructions).
2. Press the **Function** button.
Function LED 8 lights (red).
3. Press the **Select** button.
All relay LEDs light (red).
4. Press buttons 1 and 2 on the transmitter to be registered in the receiver. ¹
All function LEDs and relay LEDs flash 3 times.
5. Release the transmitter buttons.
All function LEDs and relay LEDs flash 1 time. The transmitter is registered.

If no transmitter is found within approximately 10 seconds, the receiver exits to normal operation.

¹Button 1 and 2 are factory defaults (see relevant Tele Radio AB transmitter installation instructions).

9.3 Set momentary or latching relay functions

The setting options depend on the selected **Operating mode** (see "9.4 Operating modes").



RISK OF UNINTENDED EQUIPMENT OPERATION

Ensure that the stop relays are deactivated before proceeding with the following instructions; LED 1 (#5) must be Off.

Failure to follow these instructions could result in death, serious injury, or equipment damage.

1. Press the **Function** button twice.
LED 9 lights (yellow). The relay LEDs light (red).
2. Press the **Select** button to enter the settings mode.
The relay LED for the first available relay flashes (red).
3. Press the **Function** button to change the setting for the current relay.
Relays can be set to latching or momentary and the current setting is indicated by function LED 9 (yellow).
●: LED is lit. ○: LED is off.

Function LED 9 (yellow)	Indicates
○	Momentary
●	Latching

4. Press the **Select** button to confirm the setting and move to the next available relay.
5. Repeat steps 3–4 for all available relays.

After the last relay has been programmed (depending on operating mode and hardware configuration), the receiver returns to normal operation.

9.4 Operating modes

This receiver is provided with five **Operating modes** as standard. For other **Operating modes**, contact your representative for assistance.

IMPORTANT! Operating modes 0 and 255 are reserved for specific customer applications.

- If Operation Mode 0 is used, the receiver will not qualify for PLd¹.
- If Operation Mode 255 is used, the receiver will not qualify for PLd by default, unless all safety-related parameters are manually configured according to "Chapter 3: Functional safety"². Contact your representative for assistance.

NOTE: If operating mode 255 has been selected, it is not possible to change the **Operating mode** from the receiver.

9.4.1 SHOW / CHANGE OPERATING MODE

RISK OF UNINTENDED EQUIPMENT OPERATION



Do not perform this action when the receiver is in a session with another transmitter. The radio communication may be interrupted or broken.

Failure to follow these instructions could result in death, serious injury, or equipment damage.

RISK OF UNINTENDED EQUIPMENT OPERATION



Ensure that the stop relays are deactivated before proceeding with the following instructions; LED 1 (#5) must be Off.

Failure to follow these instructions could result in death, serious injury, or equipment damage.

IMPORTANT! Always power cycle the receiver after changing from PLd to non PLd configuration (for example when changing from operating mode 1 to operating mode 5).

¹On the base board, the PLd status LED lights (red).

²On the base board, the PLd status LED lights (red). When all safety-related parameters are correctly configured, the PLd status LED will go off.

1. Press the **Function** button four times.
*Function LED 11 lights (orange). The relay LEDs indicate the current **Operating mode** according to the table below:*

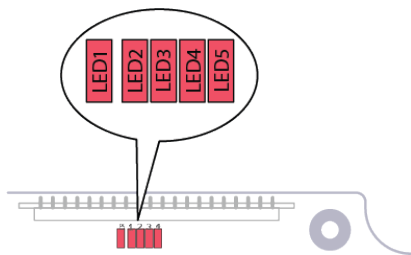

●: LED is lit. ○: LED is off.

LED 2	LED 3	LED 4	LED 5	Operating mode
○	○	○	○	0*
●	○	○	○	1 (default)
○	●	○	○	2
●	●	○	○	3
○	○	●	○	4
●	○	●	○	5
●	●	●	●	255*

**Operating modes reserved for specific customer applications. Contact your representative for assistance.*

NOTE: If no button is pressed within approximately 10 seconds, the receiver will automatically return to normal operation.

To change Operating mode:

2. Press the **Select** button.
Function LED 11 flashes (orange).
3. Press the **Function** button once to move to the next available **Operating mode** (repeat until the LED combination corresponds to the desired **Operating mode**).
The corresponding relay LEDs lights.
4. Press the **Select** button to confirm.
The new configuration is saved. The receiver returns to normal operation.

9.4.2 OPERATING MODE 1

NOTE: Only for **continuous** radio mode.

NOTE: This **Operating mode** supports **Load select** mode. See the transmitter installation instructions for available **Load select** modes.

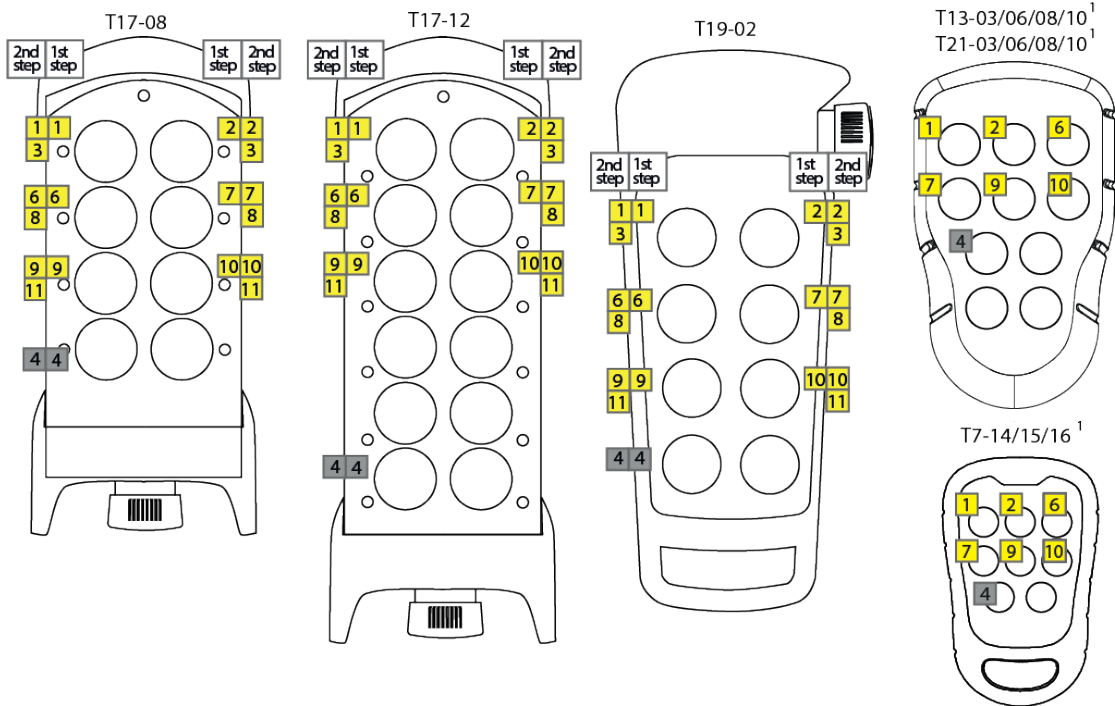

- 2 Relay number on the receiver
- Button functions
- Direction functions

On relays	Relay 5 is active when the radio link is up
Work relays	–
Load select relays	–
Programmable relay functions	Relay 4 can be set to latching
Interlocking	Between button pairs 1–2, 3–4, 5–6
Radio mode	Continuous
Zero position check	Active for all functions

¹An ON button must be set in order to work with this **Operating mode**.
The button used as OFF button cannot be used to activate a function relay.

9.4.3 OPERATING MODE 2

NOTE: Only for **continuous** radio mode.

NOTE: This **Operating mode** supports **Load select** mode. See the transmitter installation instructions for available **Load select** modes.

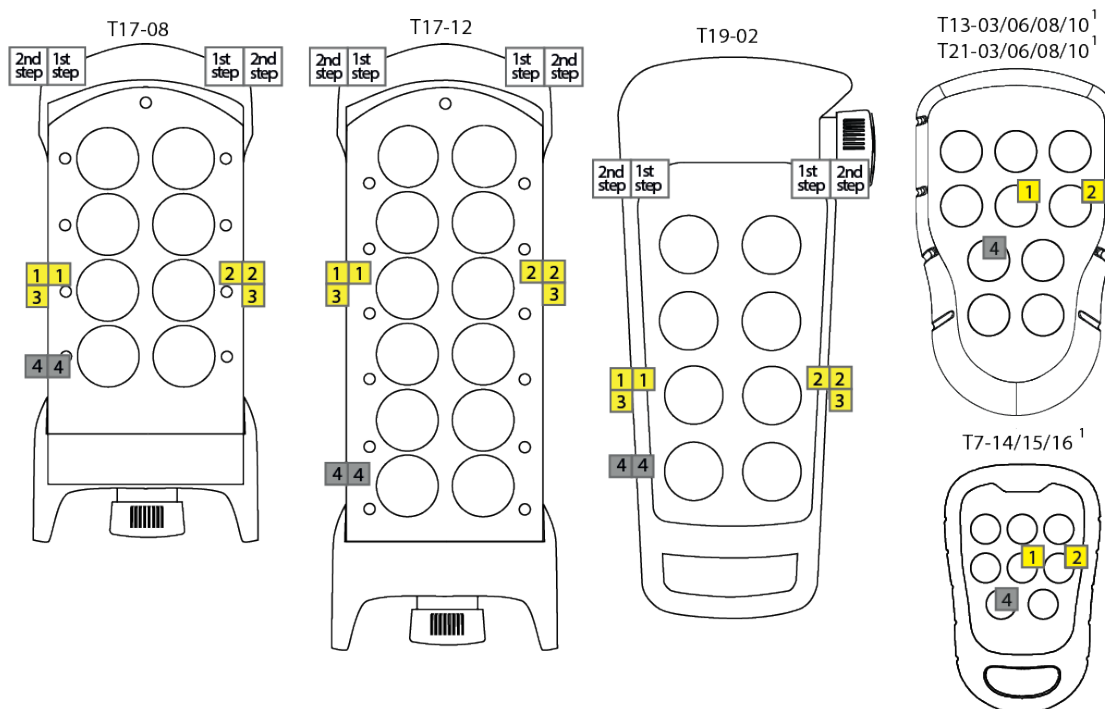

2 Relay number on the receiver

■ Button functions

■ Direction functions

On relays	Relay 5 is active when the radio link is up
Work relays	–
Load select relays	–
Programmable relay functions	Relay 4 can be set to latching
Interlocking	Between button pairs 5–6
Radio mode	Continuous
Zero position check	Active for all functions

¹An ON button must be set in order to work with this **Operating mode**.

The button used as OFF button cannot be used to activate a function relay.

9.4.4 OPERATING MODE 3

NOTE: Only for **continuous** radio mode.

NOTE: This **Operating mode** supports **Load select** mode. See the transmitter installation instructions for available **Load select** modes.

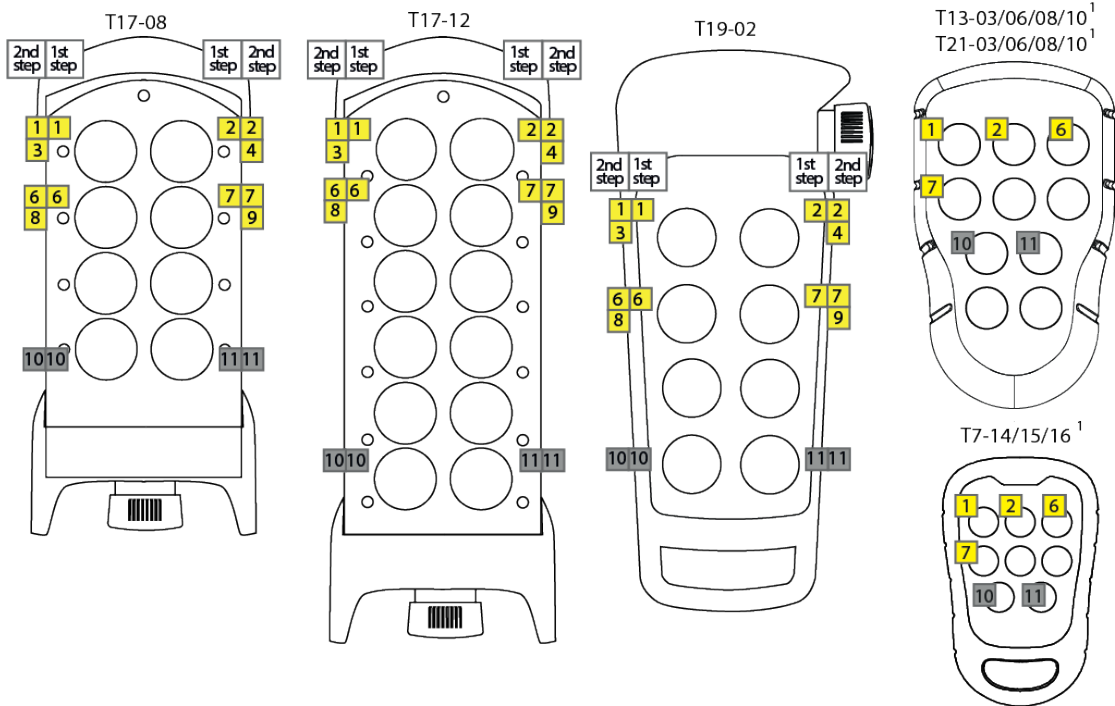

- 2 Relay number on the receiver
- Button functions
- Direction functions

On relays	Relay 5 is active when the radio link is up
Work relays	–
Load select relays	–
Programmable relay functions	Relays 10–11 can be set to latching
Interlocking	Between button pairs 1–2, 3–4
Radio mode	Continuous
Zero position check	Active for all functions

¹An ON button must be set in order to work with this **Operating mode**.
The button used as OFF button cannot be used to activate a function relay.

9.4.5 OPERATING MODE 4

NOTE: Only for **continuous** radio mode.

NOTE: This **Operating mode** supports **Load select** mode. See the transmitter installation instructions for available **Load select** modes.

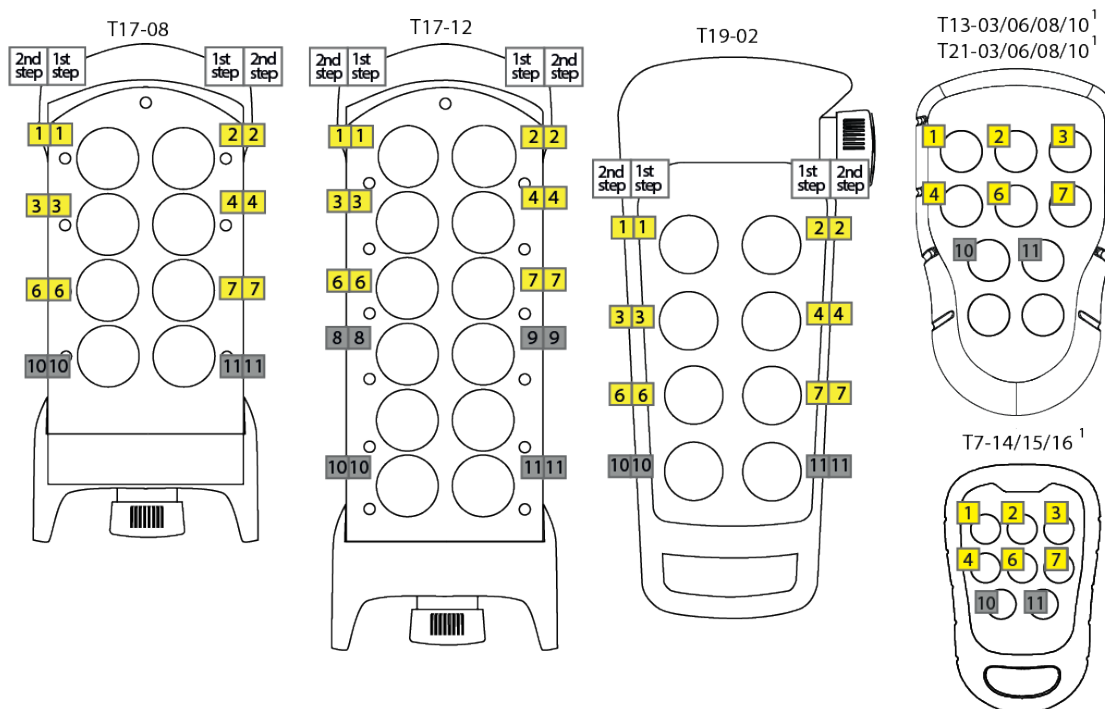

- 2 Relay number on the receiver
- Button functions
- Direction functions

On relays	Relay 5 is active when the radio link is up
Work relays	–
Load select relays	–
Programmable relay functions	Relays 10–11 can be set to latching
Interlocking	Between button pairs 1–2, 3–4, 5–6
Radio mode	Continuous
Zero position check	Active for all functions

¹An ON button must be set in order to work with this **Operating mode**. The button used as OFF button cannot be used to activate a function relay.

9.4.6 OPERATING MODE 5

NOTE: Only for **discontinuous** radio mode.

IMPORTANT! Discontinuous radio mode cancels the PLd safety classified stop function.

NOTE: This **Operating mode** supports **Load select** mode. See the transmitter installation instructions for available **Load select** modes.

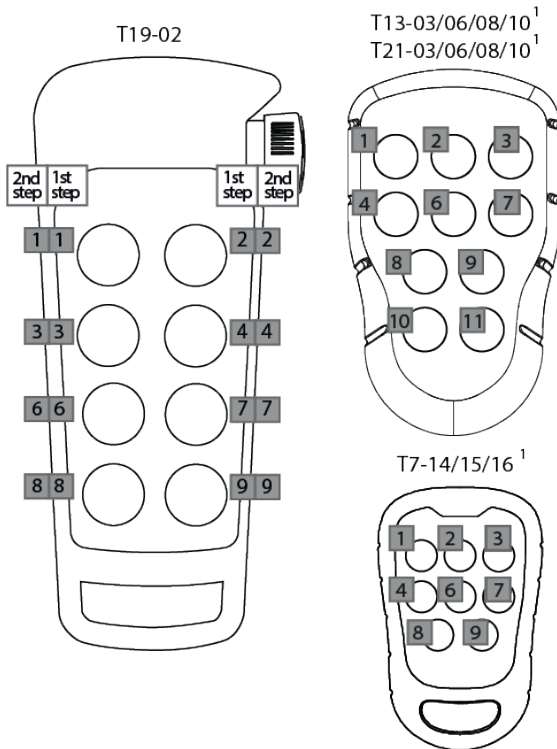

■ Button functions

On relays	–
Work relays	Relay 5 is active when the relay 1–4 or 6–11 is active
Load select relays	–
Programmable relay functions	Relays 1–4, 6–11 can be set to latching
Interlocking	–
Radio mode	Discontinuous
Zero position check	–

9.5 Active Load select

NOTE: If this setting is set to 0 (status LEDs 1–4 are off), the receiver will always be activated when receiving a radio package. For all other settings, the receiver will be activated when the load select on the transmitter corresponds to one of the load select settings enabled in the receiver.

9.5.1 SHOW LOAD SELECT

1. Press the **Function** button five times and keep it pressed until function LEDs 11 (orange) and 10 (green) light.

*The receiver is now in extended menu mode. Relay LEDs 1–4 show the current **Load select** setting according to the table below:*

●: LED is lit. ○: LED is off.

Relay LED 1 (red)	Relay LED 2 (red)	Relay LED 3 (red)	Relay LED 4 (red)	the receiver will be activated when...
●	○	○	○	Load A is selected on the transmitter
○	●	○	○	Load B is selected on the transmitter
○	○	●	○	Load C is selected on the transmitter
○	○	○	●	Load D is selected on the transmitter
○	○	○	○	The receiver does not listen to any load(s) and will always be activated when receiving a radio package.

NOTE: If no button is pressed within approximately 10 seconds, the receiver will automatically return to normal operation.

9.5.2 CHANGE LOAD SELECT

1. Press the **Select** button once.
Relay LED 1 flashes. Load A can be activated.
2. Press the **Function** button to enable/ unable the Load setting.
Function LEDs 10 (green) and 11 (orange) light when a Load has been activated. They are off when no Load has been selected.
3. Press the **Select** button once to move to the next available **Load** (repeat until the LED combination corresponds to the desired **Load select**).
The corresponding status LED flashes and the Load can be activated.

4. Press the **Select** button to confirm.
The new configuration is saved.

The receiver returns to normal operation.

9.6 Log a transmitter out

NOTE: Only for **continuous** radio mode.

NOTE: The logout function cannot be activated/deactivated in the receiver.
Contact your representative for assistance.

For this receiver, the logout function is activated by default.

NOTE: This logout option should only be used if a lost or damaged transmitter must be logged out from the receiver and the replace procedure cannot be used.

NOTE: If a transmitter has been lost or seriously damaged, use the replace procedure on the transmitter whenever possible.

Function LED 8 (red) is lit to indicate that one or more transmitter(s) are registered in the receiver and that one transmitter is logged in.



RISK OF UNINTENDED EQUIPMENT OPERATION

Ensure that the stop relays are deactivated before proceeding with the following instructions; LED 1 (#5) must be Off.

Failure to follow these instructions could result in death, serious injury, or equipment damage.

NOTE: Logout can only be performed when the transmitter is on and a radio link with one or more receivers has been established. The receiver must be powered-up for the logout procedure to be successful.

1. Press and hold the **Select** button for approx. 4 seconds or until function LED 11 goes off.
2. Release the **Select** button.
All function LEDs light briefly.

The logged in transmitter has been logged out. The receiver returns to normal operation. Any registered transmitter can now log in.

9.7 Erase all registered transmitters

NOTE: The following instructions will erase all registered transmitters from the receiver.

1. Press the **Function** button once.
Function LED 8 lights (red).
2. Press and hold the **Select** button for approx. 4 s or until all relay LEDs go off.
All registered transmitters have been erased.

The receiver returns to normal operation.

9.8 Master reset of the receiver

This procedure will erase all settings from the receiver and restore factory defaults.

NOTE: The erase function cannot be activated/deactivated in the receiver. Contact your representative for assistance.



RISK OF UNINTENDED EQUIPMENT OPERATION

Do not perform this action when the receiver is in a session with another transmitter. The radio communication may be interrupted or broken.
Failure to follow these instructions could result in death, serious injury, or equipment damage.

1. Press both the **Select** and the **Function** buttons for approx. 10 seconds or until all function LEDs go off.
2. Release both buttons.
All function LEDs light briefly. The receiver has been reset.

The receiver returns to normal operation.

CHAPTER 10: WARRANTY, SERVICE, REPAIRS, AND MAINTENANCE

Tele Radio AB products are covered by a warranty against material, construction and manufacturing faults. During the warranty period, Tele Radio AB may replace the product or faulty parts. Work under warranty must be performed by Tele Radio AB or by an authorized service center specified by Tele Radio AB.

The following are **not** covered by the warranty:

- Faults resulting from normal wear and tear
- Parts of a consumable nature
- Products that have been subject to unauthorized modifications
- Faults resulting from incorrect installation and use
- Damp and water damage

Maintenance

Repairs and maintenance must be performed by qualified personnel

Only use spare parts from Tele Radio AB

Contact your representative for service or any other assistance

Keep the product in a clean, dry place

Keep contacts and antennas clean

Wipe off dust using a slightly damp, clean cloth

NOTE: Never use cleaning solutions or high-pressure washer.

CHAPTER 11: REGULATORY INFORMATION

NOTE: Models including additional naming conventions:

Model	Article names	Additional naming conventions
R15	R15-01	R00015-01, R15-1, PN-R15-1, PN-R15-01
	R15-02	R00015-02, R15-2, PN-R15-2, PN-R15-02
	R15-07	R00015-07, R15-7, PN-R15-7, PN-R15-07
	R15-08	R00015-08, R15-8, PN-R15-8, PN-R15-08
	R15-13	R00015-13, PN-R15-13
	R15-14	R00015-14, PN-R15-14

11.1 Europe

Applies to:

R15-01, R15-02, R15-07, R15-08, R15-13, R15-14

11.1.1 CE MARKING

Hereby, Tele Radio AB, declares that the radio equipment type(s) listed above is/ are in compliance with Directive 2014/53/EU.

The latest version of the complete EU Declaration of Conformity is available on the Tele Radio AB website, www.tele-radio.com.

11.1.2 WEEE DIRECTIVE



This symbol means that inoperative electrical and electronic products must not be mixed with household waste. The European Union has implemented a collection and recycling system for which producers are responsible. For proper treatment, recovery and recycling, please take this product to a designated collection point.

Tele Radio AB strives to minimize the use of hazardous materials, promotes reuse and recycling, and reduces emissions to air, soil and water. When a commercially viable alternative is available, Tele Radio AB strives to restrict or eliminate substances and materials that pose an environmental, health or safety risk.

11.2 AEC

Applies to:

R15-01, R15-02, R15-13, R15-14

11.2.1 AEC STATEMENT (ДЕКЛАРАЦИЯ ЕАС)

This product is declared as compliant within Eurasian Economic Union (EAC). EAC declaration is available on request.

ANNEX A: FREQUENT TERMS

Configuration ID	Numerical code stored in both the transmitter and receiver unit. The receiver unit can only be controlled by a transmitter with the correct configuration ID.
Continuous radio mode	When in continuous radio mode the transmitter unit transmits continuously when it is switched on.
Custom ID	Numerical code stored in the transmitter unit, used to replace the unique ID code. One or several transmitter units can be configured with the same custom ID and the receiver will recognise them all as the same transmitter unit.
Discontinuous radio mode	When in discontinuous radio mode the transmitter unit transmits whenever it is switched on and a button is pressed. The transmission is interrupted when all buttons are released.
Function relay	Standard relay, controlled by the buttons on the transmitter unit.
Interlocking	Prevents a component from functioning when another component is functioning or operating in a particular way.
Latching relay functionality	The relay becomes active every time you press a button and remains active until the button is pressed again.
Load select mode	One or more Load select modes are stored in the transmitter unit. Activating a specific Load select mode results in a group of preselected relays on the receiver unit, which may be controlled from the transmitter unit.
Momentary relay functionality	The relay will only be active while a button is pressed on the transmitter. When the button is released, the relay will no longer be active.

On relay	Relay that is active when the receiver unit is operating and a radio link is established, regardless of whether any other relays are active.
Operating mode	One or more Operating modes are stored in the receiver unit. Each Operating mode describes which relays on the receiver unit are controlled when specific buttons on the transmitter unit are pressed.
Replace ID	Numerical code used to identify the transmitter during the Replace procedure.
Stop relay	Safety related relay controlled by the stop button on the receiver. Intended to interrupt the power supply to a safety application controlled by the receiver unit.
Work relay	Relay that is active when any other specified relay(s) on the receiver unit is/are active.
Zero position check	Security function ensuring that potentially active buttons/joysticks upon start up or lost/found radio links must be in the zero position before the system can be used to avoid unplanned movements of the controlled object.

ANNEX B: INDEX

A

About R15 receivers	8
Active Load select	42
AEC Statement	47

B

Boards	21
--------------	----

C

Configuration menu	32
Enter menu mode	32
Current consumption	17

D

Dimensions	16
------------------	----

E

Erase all registered transmitters	44
---	----

F

Function LEDs in normal operation mode	28
--	----

I

Installation precautions	20
IP code	16

L

Log a transmitter out	43
Login/Logout	31
Login/Logout function	31
Logout	43

M

Maintenance	45
-------------------	----

Master reset	44
Menu mode	
Enter menu mode	32
Mounting dimensions	
Receiver	19
N	
Number of channels	16
O	
Operating modes	35
Operating temperature	16
P	
Power supply	16
R	
Radio communication	16
Radio frequency band	16
Radio mode	31
Register	33
Relay functions	31
Relay LEDs indication	27
S	
Safety standards	16
Set momentary/latching relay functions	34
Show/ change Operating mode	35
Specifications	16
Status and error indications	27

W

Warnings & restrictions	9
Installation and commission	9
Maintenance	11
Operation	11
WEEE directive	46
Weight	16

(This page has intentionally been left blank)

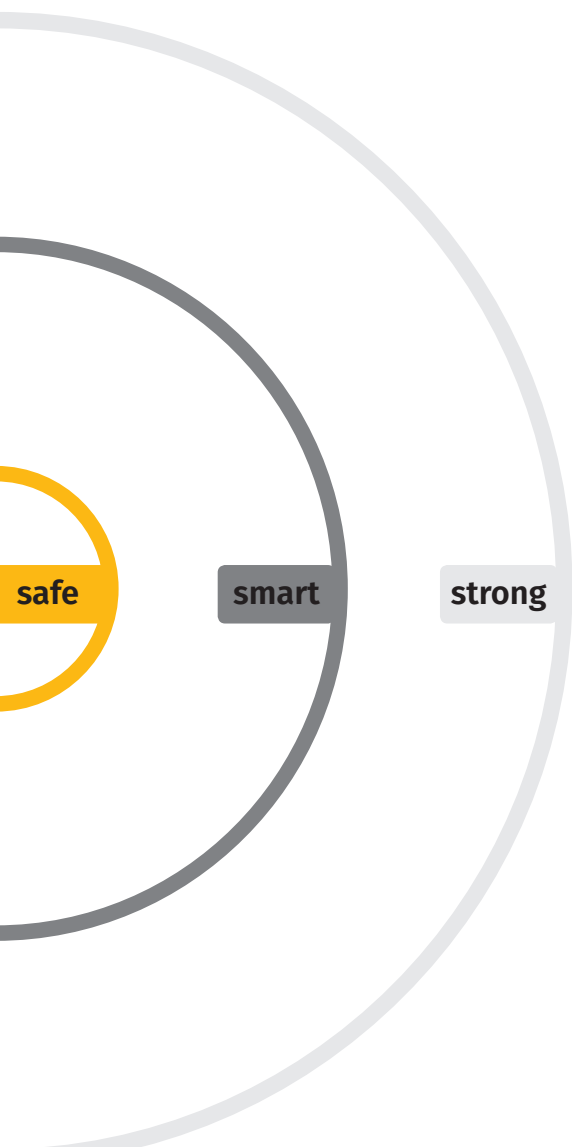

 **tele radio**[®]
wireless solutions

These Installation instructions are subject to change without prior notice.

Download the latest Installation instructions from www.tele-radio.com.