

GENERAL INFORMATION

Receivers – R15-01, R15-02, R15-07,
R15-08, R15-13, R15-14 –

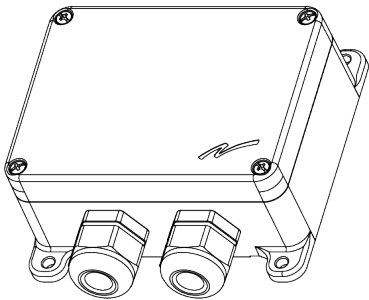

About R15 receivers

R15 receivers have simplex communication and work in either discontinuous or continuous mode.

There are six models.

	Base board	Base board	Expansion board
	48-230 V AC 4 relays*	12-24 V AC/DC 4 relays*	6-relay
R15-01	● (48-230 V AC)	–	○
R15-02	● (48-230 V AC)	–	●
R15-07	● (24-48 V AC)	–	○
R15-08	● (24-48 V AC)	–	●
R15-13	–	●	○
R15-14	–	●	●

● Standard ○ Optional – Not available

*For more details, see " Receiver specifications".

About this document

Every care has been taken in the preparation of this document. Please inform Tele Radio of any inaccuracies or omissions. This document covers general safety issues, main technical specifications, guarantee, service and maintenance, and regulatory information. For more information, please refer to the End user instructions and the Installation instructions available on www.tele-radio.com. Images shown in this document are for illustrative purposes only.

Warnings & restrictions



Carefully read through the following safety instructions before proceeding with the installation, configuration, operation, or maintenance of the product. Failure to follow these warnings could result in death or serious injury.

This product must not be operated without having read and understood the Safety information sheet, the specific technical documentation (for customized systems), and having received the appropriate training. The purchaser of this product has been instructed how to handle the system safely. The following information is intended for use as a complement to applicable local regulations and standards.

¹Must be purchased separately.

IMPORTANT! Tele Radio remote controls are often built into wider applications. These systems should be equipped with:

- a wired emergency stop where necessary
- a brake
- an audible or visual warning signal

INSTALLATION AND COMMISSIONING

IMPORTANT! Only licensed or qualified personnel should be permitted to install the product.



This radio system must not be used in areas where there is a risk of explosion.



This equipment is not suitable for use in locations where children are likely to be present.



Always switch off all electrical power from the equipment before installation procedure.



To utilize the safety features of the system, use the stop relays in the safety circuitry of the object/ equipment to be controlled.



When the equipment controlled by the receiver's standard relays is connected via the stop relays, make sure that the maximum current through the stop relays is still within the specifications. Contact your representative for assistance.



RISK OF UNINTENDED EQUIPMENT OPERATION

Only transmitters that are intended for use should be registered in the receiver. Failure to follow these instructions could result in death, serious injury, or equipment damage.



RISK OF ELECTRIC SHOCK

The receiver must only be opened by qualified installers or authorized personnel. Make sure the power supply is switched off before opening the receiver. Failure to follow these instructions could result in death, serious injury, or equipment damage.



- The receiver must be securely attached and located where it will not be hit by e.g. any moving parts.
- Do not install the product in areas affected by strong vibrations
- Cable glands and vent plugs must face downwards to prevent water ingress.
- Ensure that the power supply is connected to the correct terminals.
- Ensure that flexible cords and cables are not damaged through friction or stress.
- Do not use damaged cables.
- Ensure cables and connectors do not hang loose.

- The receiver is designed to withstand normal weather conditions but should be protected from extreme conditions.
- Mount the receiver in a location where the LEDs are easily visible and the buttons accessible.
- Make sure to install available accessories inside or on the receiver before permanently installing the receiver. A permanent installation of the product must include fuse protection of the equipment and cables against short circuits.

OPERATION



This equipment is not suitable for use in locations where children are likely to be present.



Only qualified personnel should be permitted to access the transmitter and operate the equipment.



- Make sure that the user satisfies the age requirements in your country for operating the equipment.
- Make sure that the user is not under the influence of drugs, alcohol and medications.
- Make sure that the user knows and follows operating and maintenance instructions as well as all applicable safety procedures and requirements.

The user should:



- Always test the transmitter stop button before operating it. This test should be done on each shift, without a load.
- Never use a transmitter if the stop button is mechanically damaged. Contact your supervisor or representative for service immediately.
- Never leave the transmitter unattended.
- Always switch the transmitter off when not in use. Store in a safe place.
- Keep a clear view of the work area at all times.

MAINTENANCE



Before maintenance intervention on any remote controlled equipments:

- always remove all electrical power from the equipment.
- always follow lockout procedures.

- Keep the safety information for future reference. Always download the Safety information sheet from our website, www.tele-radio.com, for the latest available version.
- If error messages are shown, it is very important to find out what caused them. Contact your representative for help.
- The functionality of the stop button should be tested at least after every 200 hours' use.
- If the stop button is mechanically damaged, do not use the transmitter. Contact your supervisor or representative for service immediately.
- Keep contacts and antennas clean.
- Wipe off dust using a clean, slightly damp cloth.
- Never use cleaning solutions.
- Check the encapsulation, foils and cable for damages. If the encapsulation or foil is damaged, moisture can cause serious damage to the electronics.

Regulatory information

NOTE: Models including additional naming conventions:

Model	Article names	Additional naming conventions
R15	R15-01	R00015-01, R15-1, PN-R15-1, PN-R15-01
	R15-02	R00015-02, R15-2, PN-R15-2, PN-R15-02
	R15-07	R00015-07, R15-7, PN-R15-7, PN-R15-07
	R15-08	R00015-08, R15-8, PN-R15-8, PN-R15-08
	R15-13	R00015-13, PN-R15-13
	R15-14	R00015-14, PN-R15-14

EUROPE

Applies to: **R15-01, R15-02, R15-07, R15-08, R15-13, R15-14**

CE MARKING



Hereby, Tele-Radio i Lysekil AB, declares that the product(s) listed above is/are in compliance with the Radio Equipment Directive 2014/53/EU.

The latest version of the complete EU Declaration of Conformity is available at the following website: www.tele-radio.com.

WEEE DIRECTIVE



This symbol means that inoperative electrical and electronic products must not be mixed with household waste. The European Union has implemented a collection and recycling system for which producers are responsible. For proper treatment, recovery and recycling, please take this product to a designated collection point.

UNITED KINGDOM

Applies to: **R15-01, R15-02, R15-07, R15-08, R15-13, R15-14**

UKCA MARKING



UK Importer: Tele Radio (UK) LTD

1 SEYMOUR COURT,
MANOR PARK, RUNCORN, WA7 1SY, UK
Email: sales@teleradiouk.com

The latest version of the complete UKCA Declaration of Conformity is available on request. Contact your representative for more information.

PRODUCT DESCRIPTION

Receiver description

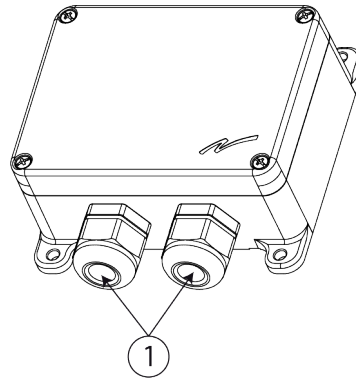

1. Cable glands (M20x1.5)

Mechanical installation

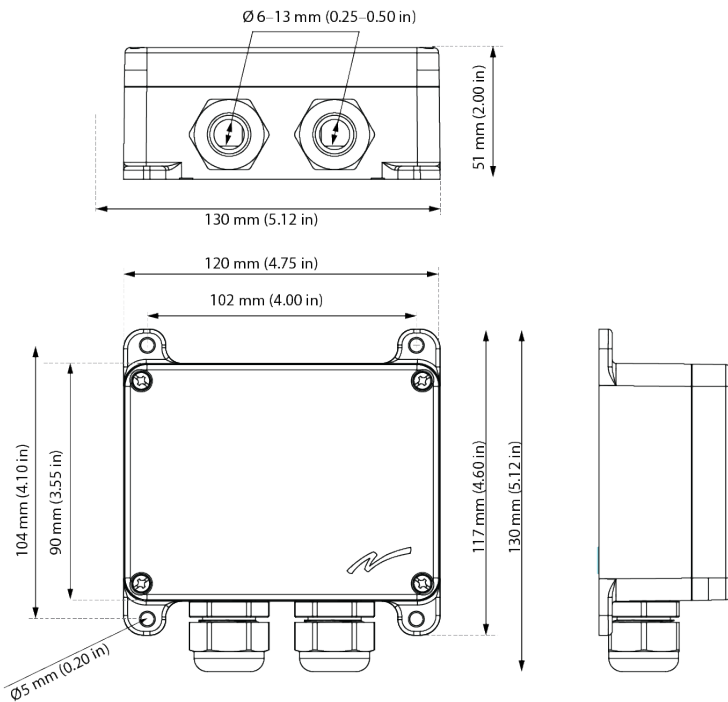

NOTE: For mounting on a wall or equipment, use 4 M5x30 mm screws or equivalent fastening method.

TECHNICAL DATA

Receiver specifications

NOTE: When the equipment controlled by the receiver's standard relays is connected via the stop relays, make sure that the maximum current through the stop relays is still within the specifications.

	R15-01	R15-02	R15-07	R15-08	R15-13	R15-14
Supply voltage	48-230 V AC [-12%...+15%]		24-48 V AC [-8%...+25%]		12-24 V AC/DC [-40%...+35%]	
Number of stop relays	2 (potential free*)					
Stop relays maximum resistive load	10 A, 250 V AC					
Stop relays maximum inductive load	4 A, 250 V AC					
Number of relays	4	10	4	10	4	10
	(potential free*, 10A, 250V AC or 30 V DC) ¹					
Relay functionality	Momentary, latching, interlocking (programmable)					
Digital inputs	-					
Radio frequency band	2405-2480 MHz					
Frequency management	Direct Sequence Spread Spectrum (DSSS)					
Number of channels	16 (channel 11-26)					
Radio communication	Simplex					
Max. number of registered transmitters	8					
Antenna	Internal antenna					
IP code	IP66					

¹ For resistive load only.

	R15-01	R15-02	R15-07	R15-08	R15-13	R15-14
Operating temperature	-20...+55 °C / -4...+130 °F					
Safety levels	EN ISO 13849-1, PLd CAT3 (Stop function)					
Dimensions (LxWxH)	120 x 117 x 51 mm / 4.7 x 4.6 x 2 in					
Weight	400 g / 0.8 lbs					

* Potential free means that a supply voltage is needed to get voltage out of a relay.

Current consumption

Input power	R15-01, R15-02		R15-07, R15-08		R15-13, R15-14	
	Min.*	Max.**	Min.*	Max.**	Min.*	Max.**
12 V AC	-	-	-	-	0.03 A	0.3 A
24 V AC	-	-	0.02 A	0.2 A	0.02 A	0.2 A
48 V AC	0.01 A	0.09 A	0.01 A	0.09 A	-	-
115 V AC	0.005 A	0.03 A	-	-	-	-
230 V AC	0.003 A	0.02 A	-	-	-	-
12 V DC	-	-	0.03 A	0.3 A	0.03 A	0.3 A
24 V DC	-	-	0.02 A	0.2 A	0.02 A	0.2 A

*Minimum current consumption = Receiver powered, no active relays, no radio session established.

**Maximum current consumption = Receiver powered, all relays on the receiver active, radio session established.

WARRANTY, SERVICE, REPAIRS, AND MAINTENANCE

Tele Radio products are covered by a warranty against material, construction and manufacturing faults. During the warranty period, Tele Radio may replace the product or faulty parts. Work under warranty must be performed by Tele Radio or by an authorized service center specified by Tele Radio.

The following are **not** covered by the warranty:

- Faults resulting from normal wear and tear
- Parts of a consumable nature
- Products that have been subject to unauthorized modifications
- Faults resulting from incorrect installation and use
- Damp and water damage

Maintenance

- Repairs and maintenance must be performed by qualified personnel
- Only use spare parts from Tele Radio
- Contact your representative for service or any other assistance
- Keep the product in a clean, dry place
- Keep contacts and antennas clean
- Wipe off dust using a slightly damp, clean cloth

NOTE: Never use cleaning solutions or high-pressure washer.

Tele-Radio i Lysekil AB, Head office

August Barks gata 30A
SE-421 32 Västra Frölunda
Sweden

Phone: +46 (0)31 748 54 60, Email: info@tele-radio.com

For more information about this product, please download the latest End user instructions or Installation instructions from www.tele-radio.com.